

INSTRUCTION & PARTS CATALOG

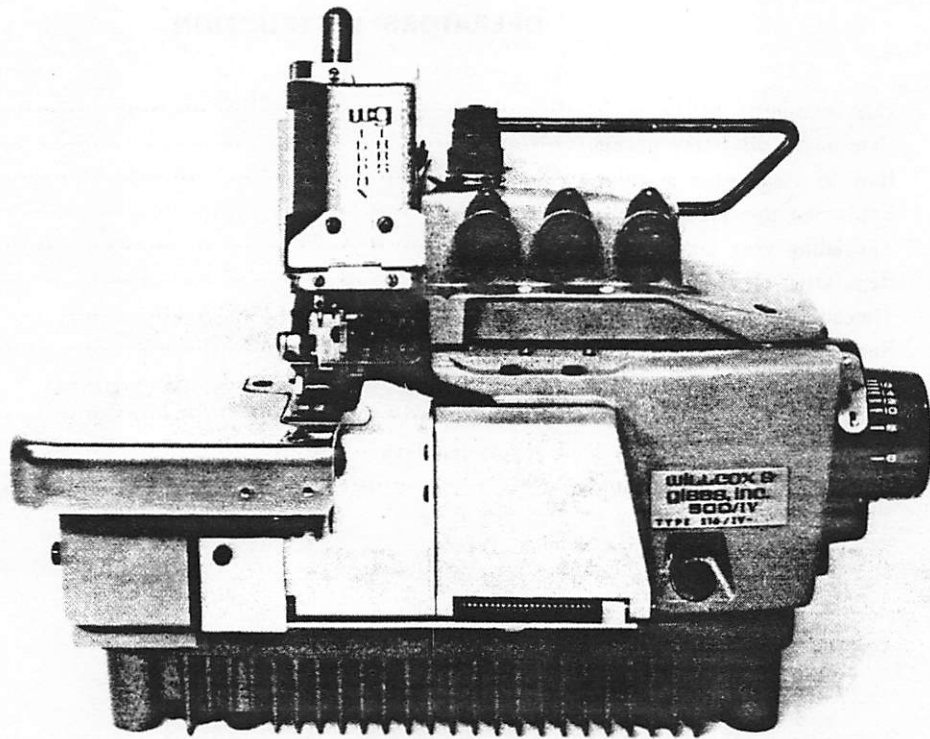

WILLCOX & GIBBS 500/IV

(overlock & safety stitch)



WILLCOX & GIBBS, INC.

1040 AVENUE OF THE AMERICAS NEW YORK, NEW YORK 10018 (212) 565-7900

TABLE OF CONTENTS.

	PAGE
Introduction	4

OPERATORS' INSTRUCTION

Lubrication.....	5
Caution to oil filter screen.....	5
How to clean your machine.....	5
Replacing the needles.....	6
Threading your machine.....	6
Regulating thread tension.....	6
Threading diagrams.....	7
Regulating seam width.....	8
Adjusting the upper and lower knives.....	8-9
Regulating the stitch length.....	9
Adjusting the differential feed regulating lever.....	10
Pressure of presser foot.....	10

MECHANICS' INSTRUCTION

Adjusting needle bar height.....	11
Adjusting needle guards.....	11
Left looper adjustment.....	12
Right looper adjustment.....	12
Right looper lever adjustment.....	13
Chainstitch looper adjustment.....	13
Chainstitch looper height adjustment.....	14
Chainstitch looper avoiding motion adjustment.....	14
Feed adjustment.....	14
Presser foot arm alignment.....	15
Presser foot lift adjustment.....	15
Chainstitch looper thread control adjustment.....	15
Timing gauges.....	16
Millimeter-inch fraction & decimal conversion chart.....	17

PARTS LIST SECTION

	PAGE
Machine bed frame	503-516/IV.. 20-21
(1) Main frame and miscellaneous covers	515-516/IV.. 22-23
(2) Main frame and miscellaneous covers	515-516/IV.. 24-25
(1) Main frame and miscellaneous covers	503-514/IV.. 26-27
(2) Main frame and miscellaneous covers	503-514/IV.. 28-29
Crankshaft mechanism	503-516/IV.. 30-31
(1) Needle drive mechanism	503-516/IV.. 32-33
(2) Needle drive mechanism	503-516/IV.. 34-35
Right looper drive mechanism	503-516/IV.. 36-37
Left looper drive mechanism	503-516/IV.. 38-39
(1) Chainstitch looper drive mechanism	515-516/IV.. 40-41
(2) Chainstitch looper drive mechanism	515-516/IV.. 42-43
(1) Main and differential feed mechanism	503-516/IV.. 44-45
(2) Main and differential feed mechanism	503-516/IV.. 46-47
Upper and lower knife mechanism	503-516/IV.. 48-49
Presser foot and lift mechanism	503-516/IV.. 50-51
(1) Pump lubricating mechanism	503-516/IV.. 52-53
(2) Pump lubricating mechanism	503-516/IV.. 54-55
(1) Attachments	56-57
(2) Attachments	58-59
(3) Attachments	60-61
Accessories	62-63
Thread stand	64-65

ORGANIZATION CHARTS

503/IV-44.	503/IV-48.	504/IV-7	68
504/IV-17.	504/IV-19.	504/IV-21	69
504/IV-25.	504/IV-43.	504/IV-45	70
504/IV-47.	504/IV-S-10.	504/IV-S-16	71
504/IV-S-17.	514/IV-11.	514/IV-12	72
514/IV-20.	514/IV-22.	514/IV-23	73
514/IV-41.	514/IV-42.	514/IV-S-11	74
514/IV-S-13.	514/IV-S-14.	514/IV-S-15	75
514/IV-S-18.	514/IV-S-19.	514/IV-S-20	76
Component parts - presser foot complete			503-514/IV.. 77
515(516)/IV-26.	515(516)/IV-27		78
515(516)/IV-28.	515(516)/IV-29		79
515(516)/IV-31.	515(516)/IV-32		80
515(516)/IV-33.	515(516)/IV-38		81
515(516)/IV-39.	515(516)/IV-51	515(516)/IV-52	82

NUMERICAL INDEX OF PARTS

Numerical index of new product code numbers with old numbers	83-90
Numerical index of old numbers with new product code numbers	91-98
Sewing organizations for 500/IV line	99
W & G 500 class model specification and summary sheet	100

INTRODUCTION

The new Willcox & Gibbs 500/IV is the latest design in Overlock and Safety stitch machines. You will benefit from its ease of handling, fast pickup in starting and smooth, quiet running. It is automatically lubricated and ruggedly designed for trouble-free performance. As the operator, you will appreciate these features helping you to gain more production with less fatigue as you operate. Willcox & Gibbs will continue to lead the way in developing new machines that will benefit the Operator, achieve more production – with greater ease.

OPERATORS' INSTRUCTION

LUBRICATION (Fig. 1, 2, 3)

CAUTION: The oil was drained from the machine when shipped. Refill with oil before operating. The 500/IV features fully automatic lubrication with a concealed forced air cooling system. The oil is pressurized by a pump to the internal surfaces of the connections through the inner Crankshaft.

A new machine should be run at least two weeks at a speed not to exceed 5,000 r.p.m. At the end of two weeks, the original oil should be drained out and replaced.

Operational speed after two weeks run-in may be 6,000 r.p.m. (Fig. 3).

Use recommended type oil only.

MACHINE SPEED	PULLEY SIZE	DIAMETER in INCHES
4900	631	3 1/8"
5100	632	3 1/4"
5275	633	3 3/8"
5450	634	3 1/2"
5650	635	3 5/8"
5825	636	3 3/4"
6000	637	3 7/8"

Fig. 3

Note: The above pulley size is based on a motor speed of approx. 3,480 r.p.m. (60Hz, 2-pole)

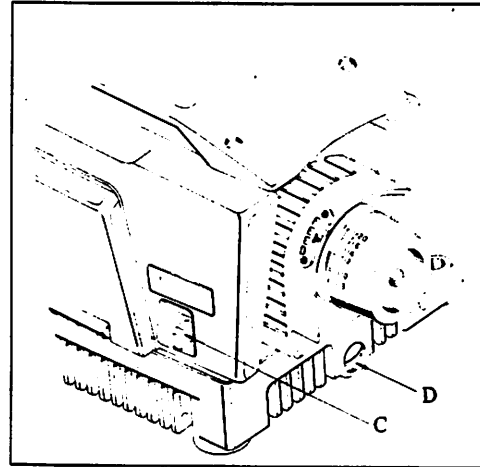

Fig. 1

To replace the oil.

Remove the machine from its stand and set it on a table. Remove Drain Plug (Fig. 1, D) which is located on the Oil Pan just below the Handwheel. Drain oil from machine. Replace the plug and return the machine to its stand.

To refill, swing out the Cloth Plate (Fig. 2, A) to the left and remove the Filler Plug (B).

Pour fresh oil into the reservoir using the funnel supplied with the accessories until the oil reaches the upper line of the Sight Gauge (Fig. 1, C).

The oil level should be kept between the two lines on the Sight Gauge.

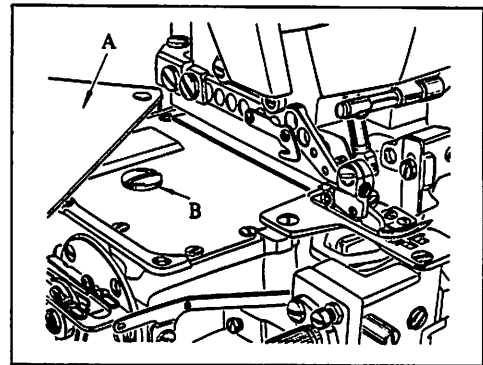

Fig. 2

CAUTION TO OIL FILTER SCREEN

The Oil Filter Screen (Fig. 4, A) should always be kept clean. Since the lubrication oil is filtered by this Screen and delivered to all the frictional surfaces, clogging of this Screen may cause lack of lubrication and accidental seizure of parts.

Check and clean the Oil Filter Screen every three months, or if necessary, replace with a new Screen when:

- the oil jet in the Oil Splash Sight Window is restricted or weak, or the oil contains foam or debris.

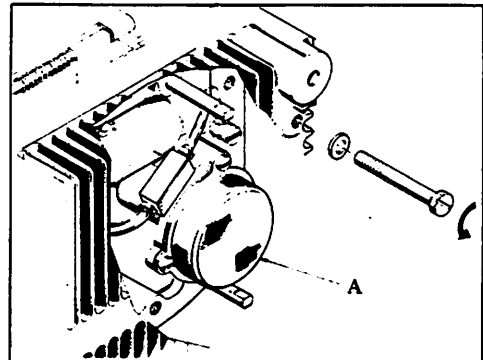

Fig. 4

HOW TO CLEAN YOUR MACHINE

Cleaning the machine is a simple but important operation. It is not necessary to remove any part. Merely release the foot and swing it out to the left. Swing out the covers and remove all the collected lint from around the loopers, feed slots, and under the needle plate. Blow out any loose lint or use a lint brush. Replace covers and return foot to the sewing position.

REPLACING THE NEEDLES (Fig. 5, 6, 7, 8)

To replace needles, turn the Handwheel until the Needle Bar is in its highest position. Lift up the Hand Lift Lever (Fig. 5, E) and swing foot to the left (F).

503, 504/IV (Fig. 6)

Loosen Needle Clamp Nut (A) and withdraw needle. Insert new needle into the needle hole as far as it will go, and position scarf of the needle to the rear of the machine. Retighten nut (A).

514/IV (Fig. 7)

515, 516/IV (Fig. 8)

Loosen Needle Clamp Screws (B) and withdraw needle. Insert new needle into the needle hole as far as it will go, and position scarf of the needle to the rear of the machine. Retighten screws (B).

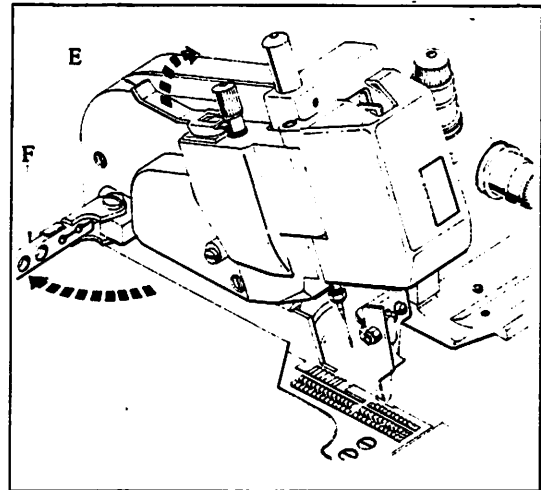

Fig. 5

503, 504/IV

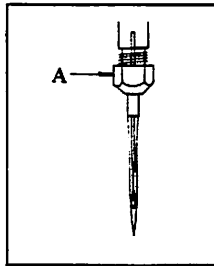

Fig. 6

514/IV

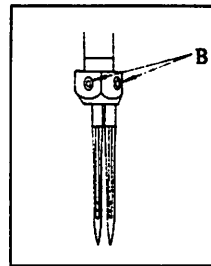

Fig. 7

515, 516/IV

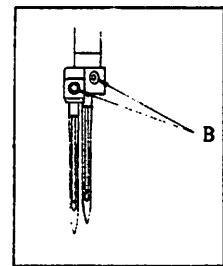

Fig. 8

THREADING YOUR MACHINE (Fig. 9, 10, 11, 12, 13, 14)

When a machine is received, note that it has been threaded correctly. The simplest way to rethread it is to tie the new threads to those already in the machine and pull the new threads through, making sure that the knots will go through the looper eyes and needles.

In case the machine requires a complete rethreading refer to the threading diagrams.

REGULATING THREAD TENSION

The amount of tension required varies with type of material, thread, stitch length, etc. Adjust individual thread tensions as follows.

To increase tension — Turn nut clockwise.

To decrease tension — Turn nut counterclockwise.

THREADING DIAGRAMS

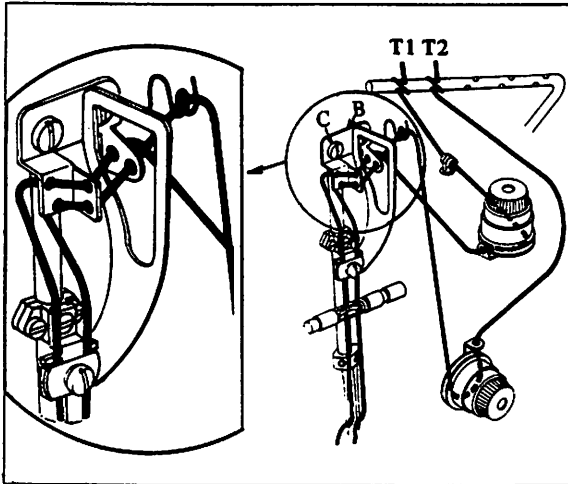

Fig. 9

503/IV, 504/IV, 514/IV

	503/IV	504/IV	514/IV
Left needle thread	Non	Non	T1
Right needle thread	T2	T2	T2
Right looper thread	Non	T8	T8
Left looper thread	T7	T9	T9

For the wetting operation which requires a loose needle tension, the Needle Thread Guide (Fig. 9, B) may be adjusted.

To decrease tension – Loosen Needle Thread Guide Screws (Fig. 9, C), move Needle Thread Guide down. Retighten screws (C).

515/IV, 516/IV

	515/IV	516/IV
Right needle thread	T3	T3
Left needle thread	T4	T4
Right looper thread	Non	T8
Left looper thread	T7	T9
Chainstitch looper thread	T10	T10

Fig. 11: Needle threading for elastic synthetic thread.

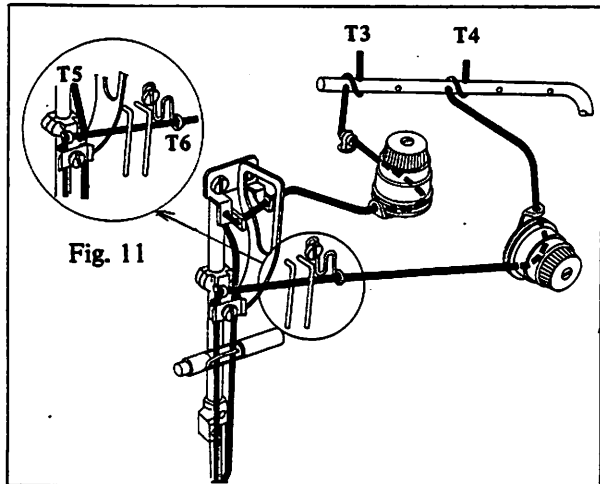

Fig. 10

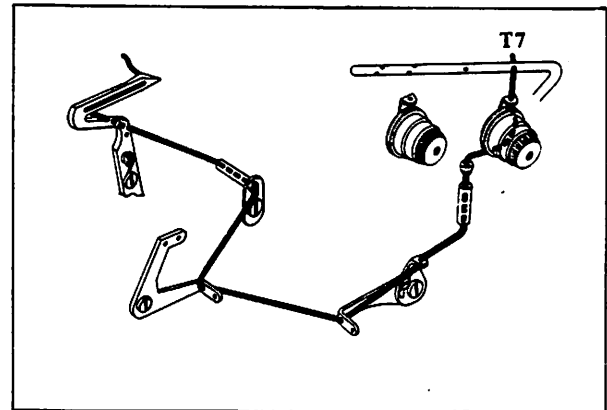

Fig. 12

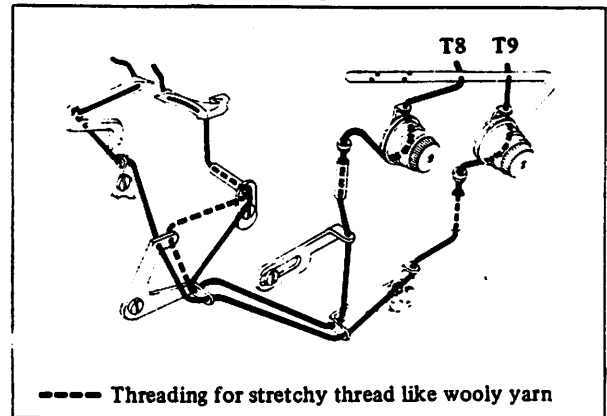

Fig. 13

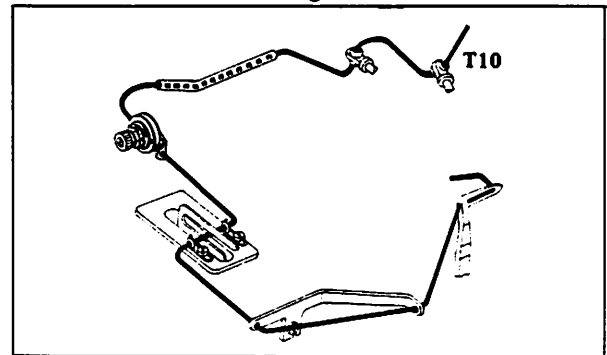

Fig. 14

REGULATING SEAM WIDTH

515, 516/IV (Fig. 15)

1. Turn the Handwheel until the Upper Knife is at its lowest point.
2. Loosen the Lower Knife Holder Screw (A). Pull the Lower Knife Holder (the Lower Knife Clamp Stud Nut. B) to the left as far as it will go and lightly tighten screw (A).
3. Loosen the Upper Knife Clamp Screws (C) and move the Upper Knife Clamp (D) to the right or left until the desired width is obtained.
4. Tighten the Upper Knife Clamp Screws (C).
5. Loosen the Lower Knife Holder Screw (A), then the Lower Knife Holder will return to position by spring action.
6. Retighten screw (A).

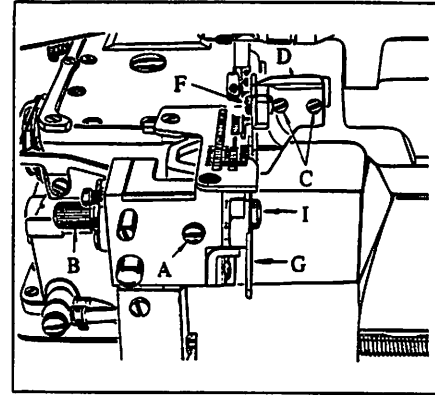

Fig. 15

503, 504, 514/IV (Fig. 16)

1. Turn the Handwheel until the Upper Knife is at its lowest point.
2. Loosen the Lower Knife Holder Screw (A). Push the Lower Knife Holder (the Lower Knife Clamp Screw. E) to the left as far as it will go and lightly tighten screw (A).
3. Loosen the Upper Knife Clamp Screws (C) and move the Upper Knife Clamp (D) to the right or left until the desired width is obtained.
4. Tighten the Upper Knife Clamp Screws (C).
5. Loosen the Lower Knife Holder Screw (A), then the Lower Knife Holder will return to position by spring action.
6. Retighten screw (A).

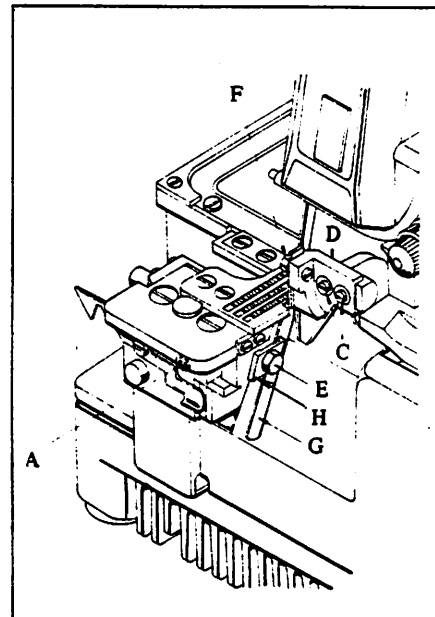

Fig. 16

ADJUSTING THE UPPER AND LOWER KNIVES

UPPER KNIFE

515, 516/IV (Fig. 15, 17)

1. Loosen the Lower Knife Holder Screw (Fig. 15, A). Pull the Lower Knife Holder (the Lower Knife Clamp Stud Nut. B) to the left as far as it will go and lightly tighten screw (A).
2. Remove the Upper Knife Nut (F) and raise the knife to remove. Replace with a new knife but do not tighten nut (F) completely.
3. Turn the Handwheel until the Knife Holder (D) is in its lowest position. Set the Upper Knife so that its cutting edge overlaps the Lower Knife by $1/32''$ (.5-1.0mm) (Fig. 17). Retighten nut (F).
4. Loosen the Lower Knife Holder Screw (A), then the Lower Knife Holder will return to position by spring action.
5. Retighten screw (A).

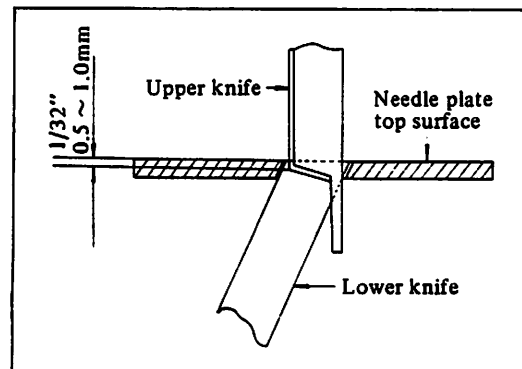

Fig. 17

ADJUSTING THE UPPER AND LOWER KNIVES (cont'd)

503, 504, 514/IV (Fig. 16, 17)

1. Loosen the Lower Knife Holder Screw (A). Push the Lower Knife Holder (the Lower Knife Clamp Screw. E) to the left as far as it will go and lightly tighten screw (A).
2. Remove the Upper Knife Screw Nut (F) and raise the knife to remove. Replace with a new knife but do not tighten nut (F) completely.
3. Turn the Handwheel until the Knife Holder (D) is in its lowest position. Set the Upper Knife so that its cutting edge overlaps the Lower Knife by 1/32" (.5-1.0mm) (Fig. 17). Retighten nut (F).
4. Loosen the Lower Knife Holder Screw (A), then the Lower Knife Holder will return to position by spring action.
5. Retighten screw (A).

LOWER KNIFE

515, 516/IV (Fig. 15, 17)

1. Loosen the Lower Knife Holder Screw (Fig. 15, A). Pull the Lower Knife Holder (the Lower Knife Clamp Stud Nut. B) to the left as far as it will go and lightly tighten screw (A).
2. Loosen the Clamp Stud Nut (B) and remove the Lower Knife.
3. Insert a new Lower Knife (G) into the groove of the Lower Knife Clamp Stud (I), setting the blade so that the cutting edge is level with the top of the Needle Plate (Fig. 17). Tighten nut (B).
4. Loosen the Lower Knife Holder Screw (A), then the Lower Knife Holder will return to position by spring action.
5. Retighten screw (A).

503, 504, 514/IV (Fig. 16, 17)

1. Loosen the Lower Knife Holder Screw (Fig. 16, A). Push the Lower Knife Holder (the Lower Knife Clamp Screw. E) to the left as far as it will go and tighten screw (A) lightly.
2. Loosen the Lower Knife Clamp Screw (E) and remove the Lower Knife.
3. Insert a new Lower Knife (G) into the Lower Knife Clamp (H), setting the blade so that the cutting edge is level with the top of the Needle Plate (Fig. 17). Tighten screw (E).
4. Loosen the Lower Knife Holder Screw (A), then the Lower Knife Holder will return to position by spring action.
5. Retighten screw (A).

Note: A right angled Upper Knife is also available as an auxiliary sales item.

Knives must be kept sharp. The Lower Knife may be sharpened by use of a grinder while making sure that the correct angle is maintained.

Upper Knife may be sent to our distributors or returned to us for resharpening since it requires special grinding.

REGULATING THE STITCH LENGTH (Fig. 18, 19)

To change the stitch length, swing Cloth Plate to the left. Loosen Feed Eccentric Push Rod Screw (Fig. 18, A) and press in the Eccentric Push Rod (B). While pressing in on the rod, turn the Handwheel in the sewing direction until the rod drops into the hole in the eccentric.

Turn the Handwheel toward the desired stitch length as shown on the Handwheel and cover for a longer or shorter stitch (Fig. 19).

Longer Stitch (less stitches per inch) – Turn Handwheel clockwise.

Shorter Stitch (more stitches per inch) – Turn Handwheel counterclockwise.

When desired stitch length is obtained, release the rod (B) and tighten screw (A)

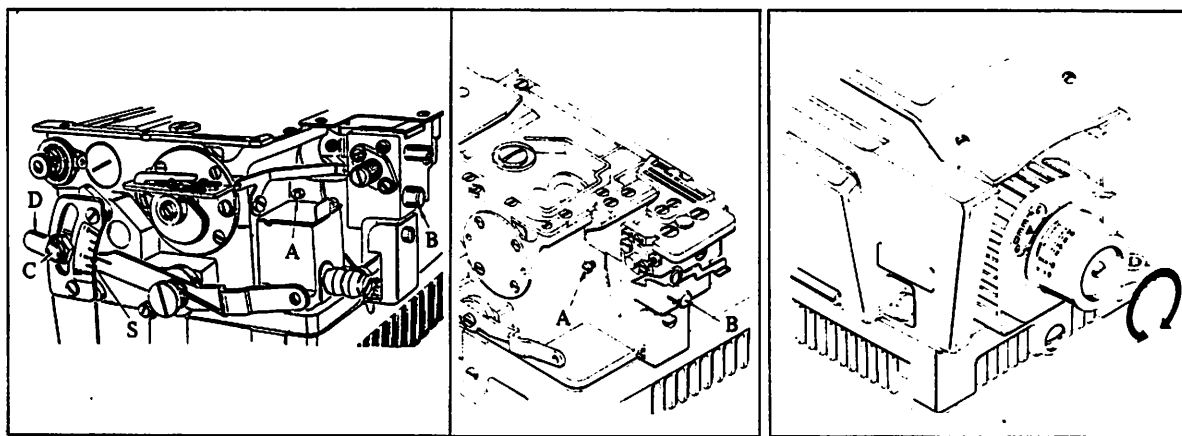

(515, 516)

Fig. 18

(503, 504, 514)

Fig. 19

ADJUSTING THE DIFFERENTIAL FEED REGULATING LEVER (Fig. 18, 20)

The following feed ratios are preset at the factory.

Seaming machines 1/2:1 stretch to 2:1 filling

Shirring machines 1:1 seaming to 3:1 shirring

TO ADJUST:

Seaming Machines – Loosen Thumb Nut (C). Line up mark on Differential Lever (D) with setting shown on Indicator Plate (S). Retighten nut (C).

(Fig. 18)

INDICATOR PLATE SETTING = DIFFERENTIAL : MAIN FEED RATIO

1.8 = 2 : 1 filling

1 = 1 : 1

0.6 = 1/2 : 1 stretch

Shirring Machines – Intermittent shirring can be obtained by use of the Knee Control provided with Shirring Machines. When the range has been set the adjustable stops (E) are positioned and Thumb Nut (C) is left loose.

(Fig. 20)

INDICATOR PLATE SETTING = DIFFERENTIAL : MAIN FEED RATIO

3 = 3 : 1 shirring

2 = 2 : 1 shirring

1 = 1 : 1 seaming

Please note all settings are approximate figures that will vary with fabric weights, thread, stitch length, etc.

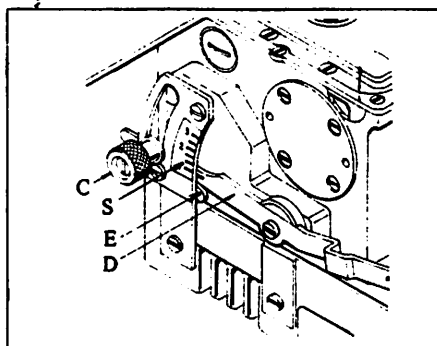

Fig. 20

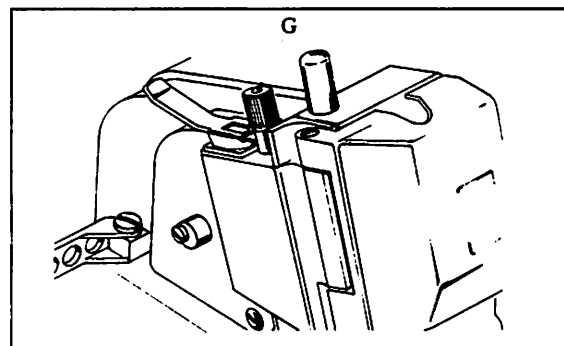

Fig. 21

PRESSURE OF PRESSER FOOT

Pressure of the Presser Foot is regulated by means of the Presser Regulating Thumb Screw (Fig. 21, G). Pressure on the Presser Foot should be just enough to feed material and obtain proper stitch formation. Too much pressure may spoil material and give it more stretch than it needs. Too little pressure may cause uneven feeding or stitches.

MECHANICS' INSTRUCTION

ADJUSTING NEEDLE BAR HEIGHT (Fig. 22, 23, 24)

With a new needle in the machine, turn the Handwheel until the needle is in its highest position. Use Timing Gauge, check the clearance between the point of the needle and the top of the Needle Plate. If clearance is not correct, loosen the Needle Bar Connecting Bracket Screw and reset the Needle Bar correctly. Check to make sure the needle is in the center of the needle hole and tighten the bracket screw securely.

FEDERAL STITCH	MODEL	DIMENSION		FIG.	NOTE
		INCH	MM		
503	503/IV	.410	10.4	22	
504	504/IV	.410	10.4	22	
505	505/IV	.410	10.4	22	
512	514/IV	.465	11.8	23	check to the left needle
514	514/IV	.465	11.8	23	check to the left needle
515	515/IV	.418	10.6	24	check to the right needle
516	516/IV	.418	10.6	24	check to the right needle

EXCEPTIONS:

515 (516)/IV-38, -39398" 10.1mm
 515 (516)/IV-51, -52473" 12.0mm

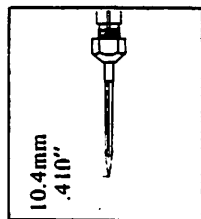

Fig. 22

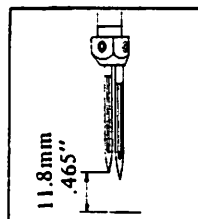

Fig. 23

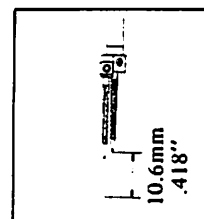

Fig. 24

ADJUSTING NEEDLE GUARDS (Fig. 25, 26, 27, 28)

Machine are fitted with both front and rear needle guards. Set Rear Guard first.

Rear Needle Guard

515, 516/IV (Fig. 25, 27)

Turn Handwheel until Needle Bar is at its lowest position. Loosen two screws (U) holding Needle Guard Bracket. Move bracket until the top of the Overlock needle eye is .020" (0.5mm) below the line (T) of the Needle Guard, Rear. Tighten screws (U). Loosen screw (R) holding Needle Guard, Rear. When point of the Left Loper comes to the centerline of the needle, adjust the Needle Guard (S) back and forth so that it lightly touches the needle. Tighten screw (R).

503, 504, 514/IV (Fig. 26, 27)

Turn Handwheel until Needle Bar is at its lowest position.

Loosen two screws (N) holding Needle Guard Bracket. When point of the Left Loper comes to the centerline of the needle, adjust the Needle Guard (S) back and forth so that it lightly touches the needle. Tighten bracket screws (N).

Front Needle Guard (Fig. 28)

Adjust Needle Guard so there is a space of .004 - .008" (.1 - .2mm) between the Needle and Guard.

CAUTION: Needle Guard must be reset when needle size is changed.

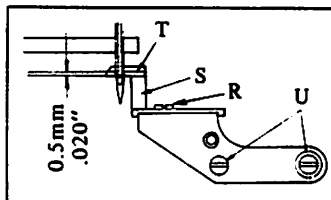

Fig. 25

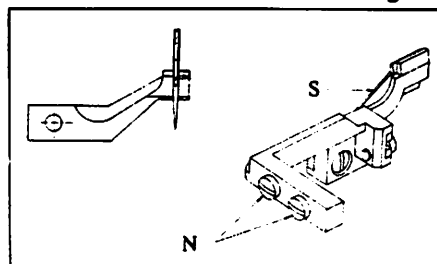

Fig. 26

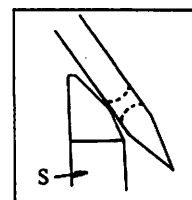

Fig. 27

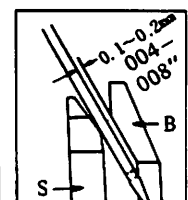

Fig. 28

LEFT LOOPER ADJUSTMENT (Fig. 29, 30)

Clearance from point of Looper to centerline of Needle

FEDERAL STITCH	MODEL	DIMENSION	
		INCH	MM
503	503/IV	.154 (5/32)	3.9
504	504/IV	.154 (5/32)	3.9
505	504/IV	.154 (5/32)	3.9
512	514/IV	.154 (5/32)	3.9
514	514/IV	.169 (11/64)	4.3
515	515/IV	.154 (5/32)	3.9
516	516/IV	.154 (5/32)	3.9

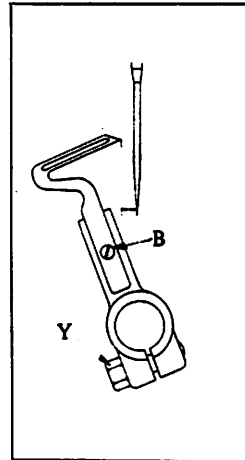

Fig. 29

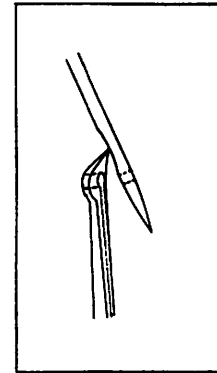

Fig. 30

Insert the Looper into the Looper Lever, making sure it reaches the bottom of slot. Tighten screw (B). Turn the Handwheel until the Looper is in the extremely left position.

Loosen clamp screw (Fig. 29, Y). Set point of Looper from centerline of Needle to correct dimension shown above and lightly tighten screw (Y). Turn Handwheel until Looper point is on the centerline of the Needle. Move Looper Lever, if necessary, along its shaft so that the Looper point just touches the needle at the scarf (Fig. 30), tighten screw (Y). Recheck clearance dimension and tighten screw (Y) securely.

RIGHT LOOPER ADJUSTMENT (Fig. 31, 32, 33, 34, 35)

Clearance from Looper (eye) or Spreader (bottom of V groove) to centerline of Needle (Fig. 31, 32).

FEDERAL STITCH	MODEL	DIMENSION	
		INCH	MM
503	503/IV	.130 (1/8)	3.3
504	504/IV	.130 (1/8)	3.3
505	504/IV	.130 (1/8)	3.3
512*	514/IV*	-0-*	-0-*
514	514/IV	.157 (5/32)	4.0
515	515/IV	.130 (1/8)	3.3
516	516/IV	.130 (1/8)	3.3

* aligned with left needle eye

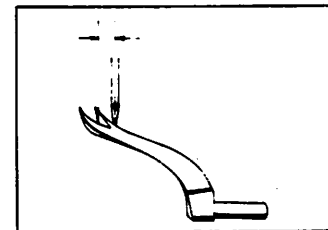

Fig. 31

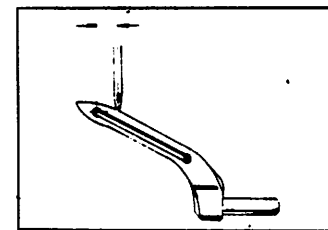

Fig. 32

Turn Handwheel until the Looper is at its extremely left position. Loosen clamp screw (Fig. 35, K) and move Looper until necessary dimension is obtained as listed above.

At the same time, make sure the Looper points cross as shown in Fig. 33.

Clearance between the Needle (N) and Right Looper should be .004 - .008" (0.1 - 0.2mm) (Fig. 34).

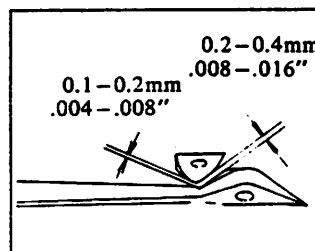

Fig. 33

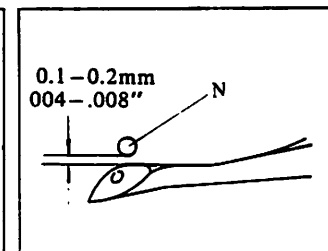

Fig. 34

If the Right Looper strikes the Left Looper in passing, advance or retard the timing by adjusting the Right Looper Lever.

RIGHT LOOPER LEVER ADJUSTMENT (Fig. 35)

Turn Handwheel until the Right Looper is at its lowest position.
Clearance between Crank Pin and Machine Bed should be:

MODEL	DIMENSION	
	INCH	MM
503/IV	.157 (5/32)	4.0
515/IV	.157 (5/32)	4.0
504/IV	.138 (9/64)	3.5
514/IV	.138 (9/64)	3.5
516/IV	.138 (9/64)	3.5

Note: To check this setting the Oil Pan must be removed.

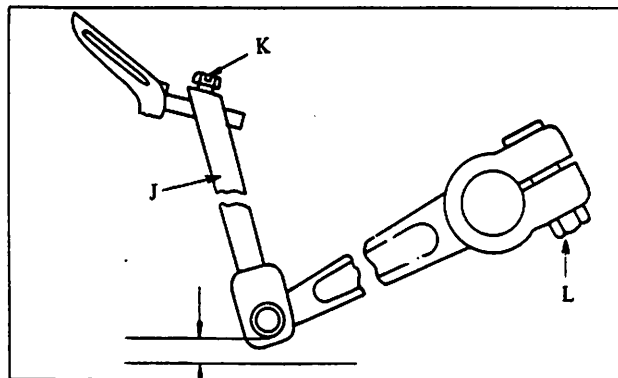

Fig. 35

If adjustment is necessary, loosen clamp screw (L).

Adjust the Looper Lever (J) up or down until the correct setting is obtained. Retighten clamp screw (L). Adjust the Looper back and forth, right and left in the holder. Retime the Looper to the Needle since raising or lowering the lever will alter the distance between the Looper eye and Needle centerline. Securely tighten screw (K) and (L). Replace Oil Pan.

CAUTION: Make sure when tightening screw (L) that you do not twist the Looper Lever causing a bind in the machine.

Various Right Loopers are provided as listed below for use with various size needles.

For ease of identification looper-have been marked with a looper marking.

	MODEL	LOOPER MARKING	NEEDLE SIZE IDENTIFICATION			PART NUMBER	
			SINGER	W & G	METRIC	515-516/IV	503-514/IV
2 thread	503-515/IV	1	9-12	027-032	65-80	204278 323-810-215	
		3	13-16	034-040	85-100	204704 323-810-011	204704 323-810-011
		5	17-21	042-051	100-140	204705 323-810-012	
3 thread	504-516/IV	2	9-12	027-032	65-80	204062 323-810-218	204062 323-810-218
		4	13-16	034-040	85-100	204702 323-810-009	204702 323-810-009
		6	17-21	042-051	100-140	204703 323-810-010	204703 323-810-010
4 thread	514/IV	7	9-14	027-036	65-90		204663 323-810-008

CHAINSTITCH LOOPER ADJUSTMENT (Fig. 36, 37, 38)

Clearance from point of Looper to centerline of Needle

MODEL	INCH	MM
515-516/IV	.083 (5/16)	2.1

Insert Chainstitch Looper into Looper Lever (Fig. 36, O) until it touches the Looper Regulator (P).

Tighten screw (Q). Turn Handwheel until the Looper is at its extremely left position (Fig. 37).

Loosen clamp screw (R) and move Looper Lever until the necessary clearance is obtained. Tighten screw (R).

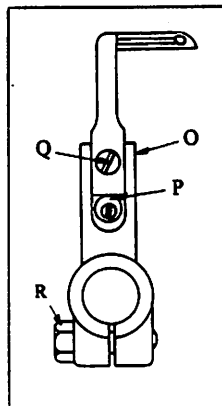

Fig. 36

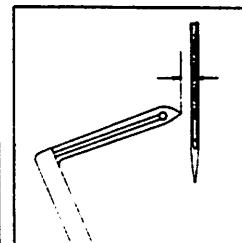

Fig. 37

CHAINSTITCH LOOPER HEIGHT ADJUSTMENT (Fig. 38)

Turn Handwheel and check the eye to eye relationship of the needle and Looper. The eye of the needle and the eye of the Looper should cross when the Looper is coming in to the needle and on the way back. If the eye to eye relationship is not obtained, adjust the Looper Regulator (Fig. 36, P) to the left or right. This adjustment will raise or lower the Looper eye.

The Looper must be set so that the point of the Looper does not quite touch the needle as it passes. When the above settings are complete, tighten clamp screw (R) securely.

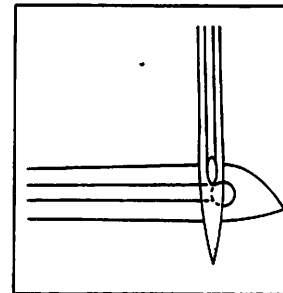

Fig. 38

CHAINSTITCH LOOPER AVOIDING MOTION ADJUSTMENT (Fig. 39)

To change the looper avoiding motion due to the diameter of the needle. When larger or smaller needles are fitted to the machine make the following adjustment.

Swing out Cloth Plate. Remove Bedplate. Loosen Looper Avoiding Connection Pin Nut. Turn Looper Avoiding Regulating Screw. (Fig. 39, G).

Less motion – Turn screw clockwise. This will raise the Looper Avoiding Connection Pin.

More motion – Turn screw counterclockwise. This will lower the Looper Avoiding Connection Pin.

Check that the Chainstitch Needle passes just behind the Chainstitch Looper on the downstroke. Retighten Looper Avoiding Connection Pin Nut. Replace Bedplate and Cloth Plate.

FEED ADJUSTMENT (Fig. 39, 40, 41)

Feed Dogs have generally been preset at the factory with a front to back tilt when the machine was sewn off. Before adjusting feeds, turn the Handwheel until the feeds are at their highest position.

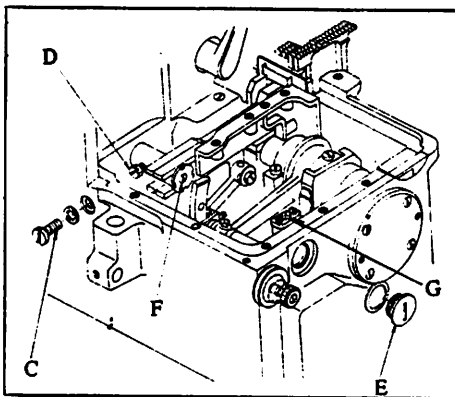

Fig. 39

Standard height of Main Feed is 0.47" (3/64) 1.2mm above the needle plate at its rearend tooth. A straight edge can be placed across the top of the feeds (Fig. 41).

Loosen Feed Dog Screws (Fig. 40, A & B) and raise or lower feeds until the proper height is obtained (Fig. 41).

Retighten screws (A & B).

To tilt the Feed Dogs, remove Plug Screw (Fig. 39, C) and loosen Feed Bar Hinge Pin Screw (D). Remove screw (E) and turn screw (F) until the desired tilt is obtained.

Retighten screw (D) and replace screws (C & E).

Woven materials – Set feeds level

Knit materials – Tilt feeds higher in the front than the rear

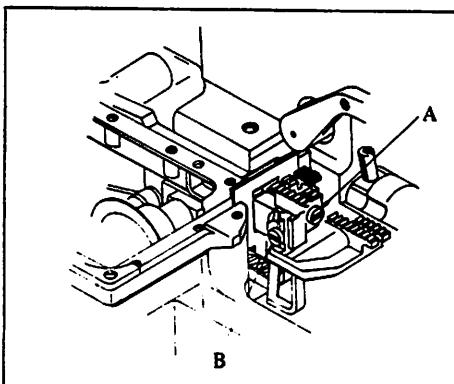

Fig. 40

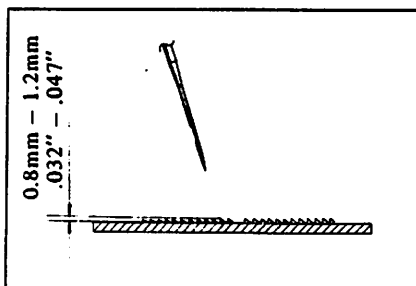
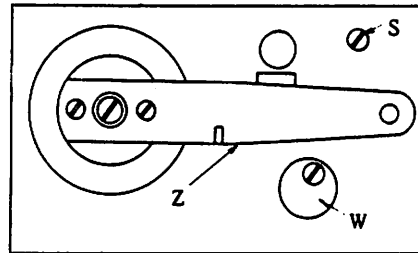

Fig. 41

PRESSER FOOT ARM ALIGNMENT (Fig. 42)

Loosen screw (S) and move Presser Arm (P) to the right or left until the face of the Presser Arm touches the Machine Arm evenly. Securely tighten screw (S).



503, 504, 514/IV

515, 516/IV Fig. 42

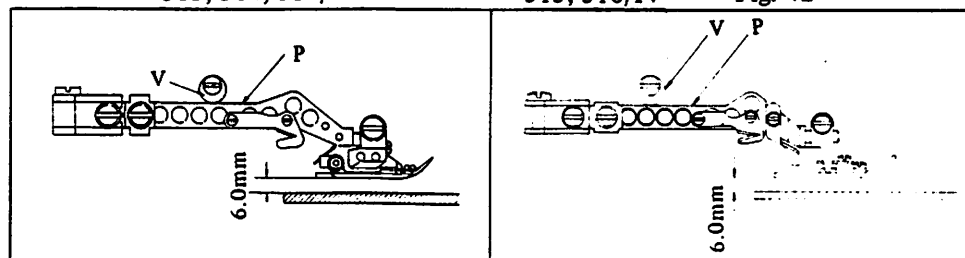

Fig. 43

PRESSER FOOT LIFT ADJUSTMENT (Fig. 42, 43, 44)

Loosen screws holding Regulators (Fig. 42, W & Fig. 43, V). Turn Regulators to allow the highest lift.

Tighten both screws.

Turn Handwheel until Needle Bar is in the lowest position. Remove (2) lock screws (Fig. 44, N).

Turn screw (M) left or right until a lift is obtained of .236" (15/64) 6.0mm.

Replace screws (N). After this setting has been made, position Regulators (V & W) as stops so they are in contact with the Presser Arm (P) and Foot Lift Lever (Z).

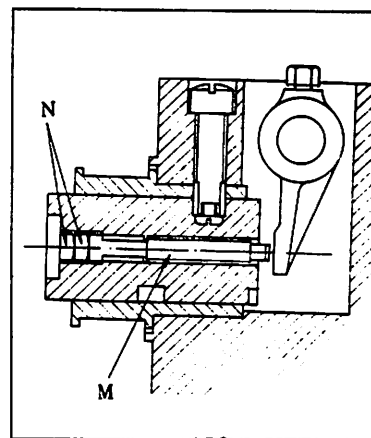

Fig. 44

CHAINSTITCH LOOPER THREAD CONTROL ADJUSTMENT (Fig. 45)

Loosen screws holding Looper Thread Takeup Eyelets (A) and move eyelets until the coiled ends line up with the engraved line on Guide Bracket (B). Tighten both screws.

Turn Handwheel until the Needle Bar is at the highest position. Loosen the two screws holding bracket (B). Set the bracket in a horizontal position. With the left screw loose, position Looper Thread Takeup Guide (D) so that the bottom edge of guide (D) is .060" (1/16) 1.5mm above the top of bracket (B). Tighten both screws securely.

Loosen the two screws holding takeup (C) and turn the Handwheel until the Needle Bar is at the highest position. Set the takeup (C) so that the flat portion is at a 10° angle to bracket (B). Tighten takeup screws. Check to make sure that the takeup clears guide (D).

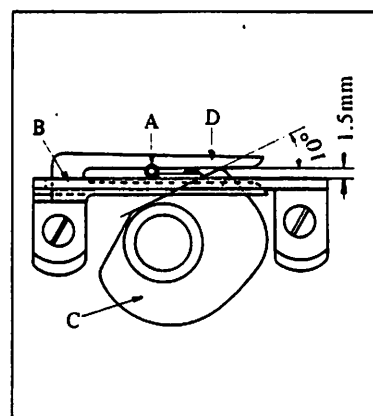
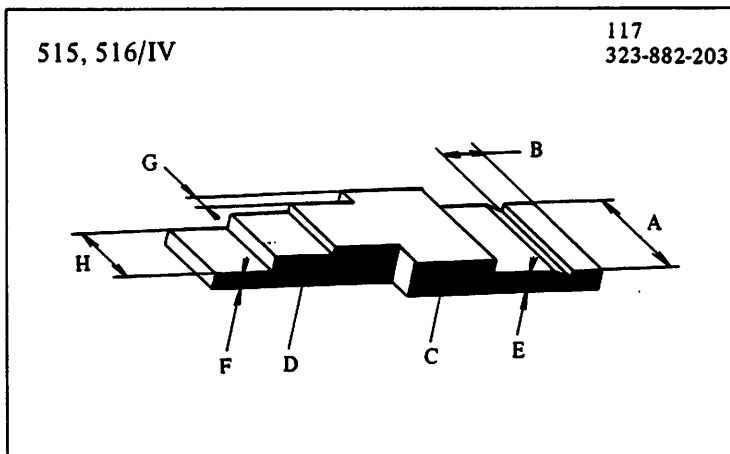

Fig. 45

TIMING GAUGES

515, 516/IV

117
323-882-203



503, 504/IV

185
323-882-002

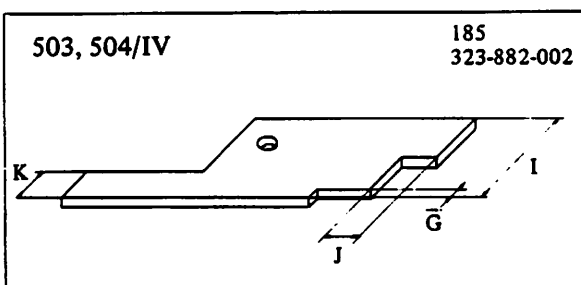

514/IV

186
323-882-003

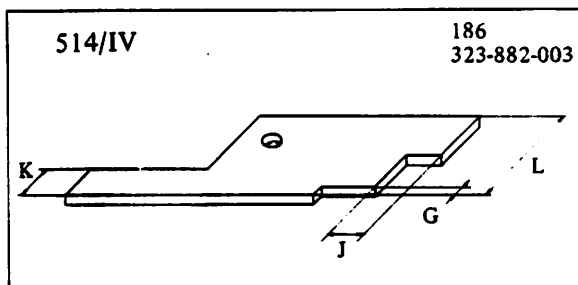

RESPECTIVE POSITIONS REQUIRED AT MEASURING

- A) Right Needle, at upper dead Point.
- B) Right Looper, at left dead Point.
- C) Left Looper, at left dead Point.
(Needle Size 11)
- D) Left Looper, at left dead Point.
(Needle Size 14)
- E) Chainstitch Looper, at left dead Point.
(Needle Size 11)
- F) Chainstitch Looper, at left dead Point.
(Needle Size 14)
- G) Main Feed Dog, at upper dead Point.
- H) Highest height of Presser Foot lifted.
- I) Needle, at upper dead Point.
- J) Right Looper, at left dead Point.
(Needle Size 9)
- K) Left Looper, at left dead Point.
(Needle Size 9)
- L) Left Needle, at upper dead Point.

BASIC POSITIONS ON MEASURING

- from Needle Plate top to Needle Point.
- from Left side of Needle to Looper Thread Eye Center.
- from Left side of Needle to Looper Point.
- from Left side of Needle to Looper Point.
- from Left side of Needle to Looper Point.
- from Left side of Needle to Looper Point.
- from Left side of Needle to Looper Point.
- from Needle Plate top to top Edges of Teeth.
- from Needle Plate top to Sole of Presser Foot.
- from Needle Plate top to Needle Point.
- from Left side of Needle to Looper Thread Eye Center.
- from Left side of Needle to Looper Point.
- from Needle Plate top to Needle Point.

**MILLIMETER-INCH FRACTION & DECIMAL
CONVERSION CHART**

MM	APPR. INCH FRACT.	DECIMAL	MM	APPR. INCH FRACT.	DECIMAL	MM	APPR. INCH FRACT.	DECIMAL
0.1		.004	3.4		.134	6.7	17/64	.264
0.2		.008	3.5		.138	6.8		.268
0.3	1/64	.012	3.6	9/64	.142	6.9		.272
0.4	1/64	.016	3.7		.146	7.0		.276
0.5		.020	3.8		.150	7.1	9/32	.280
0.6		.024	3.9		.154	7.2		.283
0.7		.028	4.0	5/32	.157	7.3		.287
0.8	1/32	.032	4.1		.161	7.4		.291
0.9		.035	4.2		.165	7.5	19/64	.295
1.0		.039	4.3		.169	7.6		.299
1.1		.043	4.4	11/64	.173	7.7		.303
1.2	3/64	.047	4.5		.177	7.8		.307
1.3	3/64	.051	4.6		.181	7.9	5/16	.311
1.4		.055	4.7		.185	8.0		.315
1.5		.059	4.8	3/16	.189	8.1		.319
1.6	1/16	.063	4.9		.193	8.2		.323
1.7		.067	5.0		.197	8.3	21/64	.327
1.8		.071	5.1		.201	8.4		.330
1.9		.075	5.2	13/64	.205	8.5		.335
2.0	5/64	.079	5.3		.209	8.6		.339
2.1		.083	5.4		.213	8.7	11/32	.343
2.2		.087	5.5		.217	8.8		.346
2.3		.091	5.6	7/32	.220	8.9		.350
2.4	3/32	.094	5.7		.224	9.0		.354
2.5		.098	5.8		.228	9.1	23/64	.358
2.6		.102	5.9		.232	9.2		.362
2.7		.106	6.0	15/64	.236	9.3		.366
2.8	7/64	.110	6.1		.240	9.4		.370
2.9		.114	6.2		.244	9.5	3/8	.374
3.0		.118	6.3		.248	9.6		.378
3.1		.122	6.4	1/4	.252	9.7		.382
3.2	1/8	.125	6.5		.256	9.8		.386
3.3		.130	6.6		.260	9.9	25/64	.390
			6.7			10.0		.394
			6.8					
20.0	25/32	.787	50.0	1-31/32	1.968	80.0	3-5/32	3.150
30.0	1-3/16	1.181	60.0	1-23/64	2.362	90.0	3-35/64	3.543
40.0	1-37/64	1.575	70.0	2-3/4	2.756	100.0	3-15/16	3.937

WILLCOX & GIBBS 500/IV

PARTS CATALOG

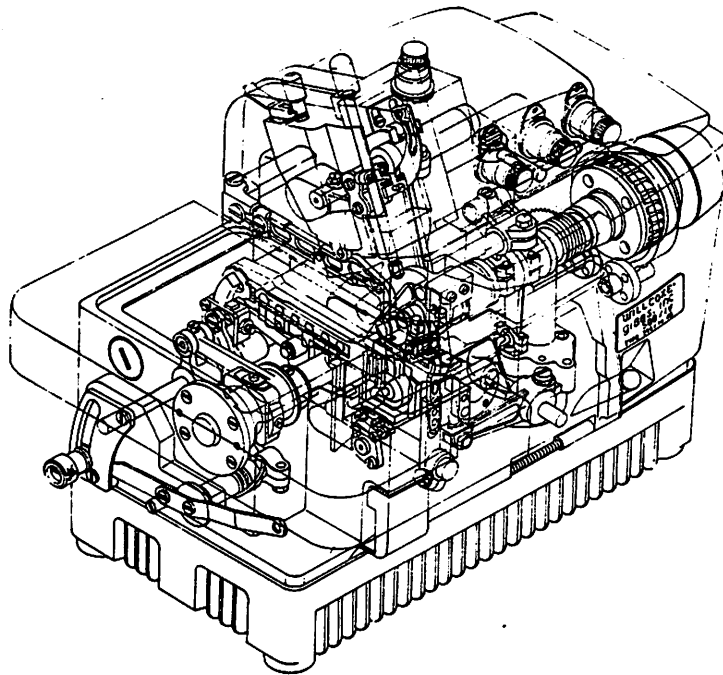

503-516/IV
MACHINE BED FRAME

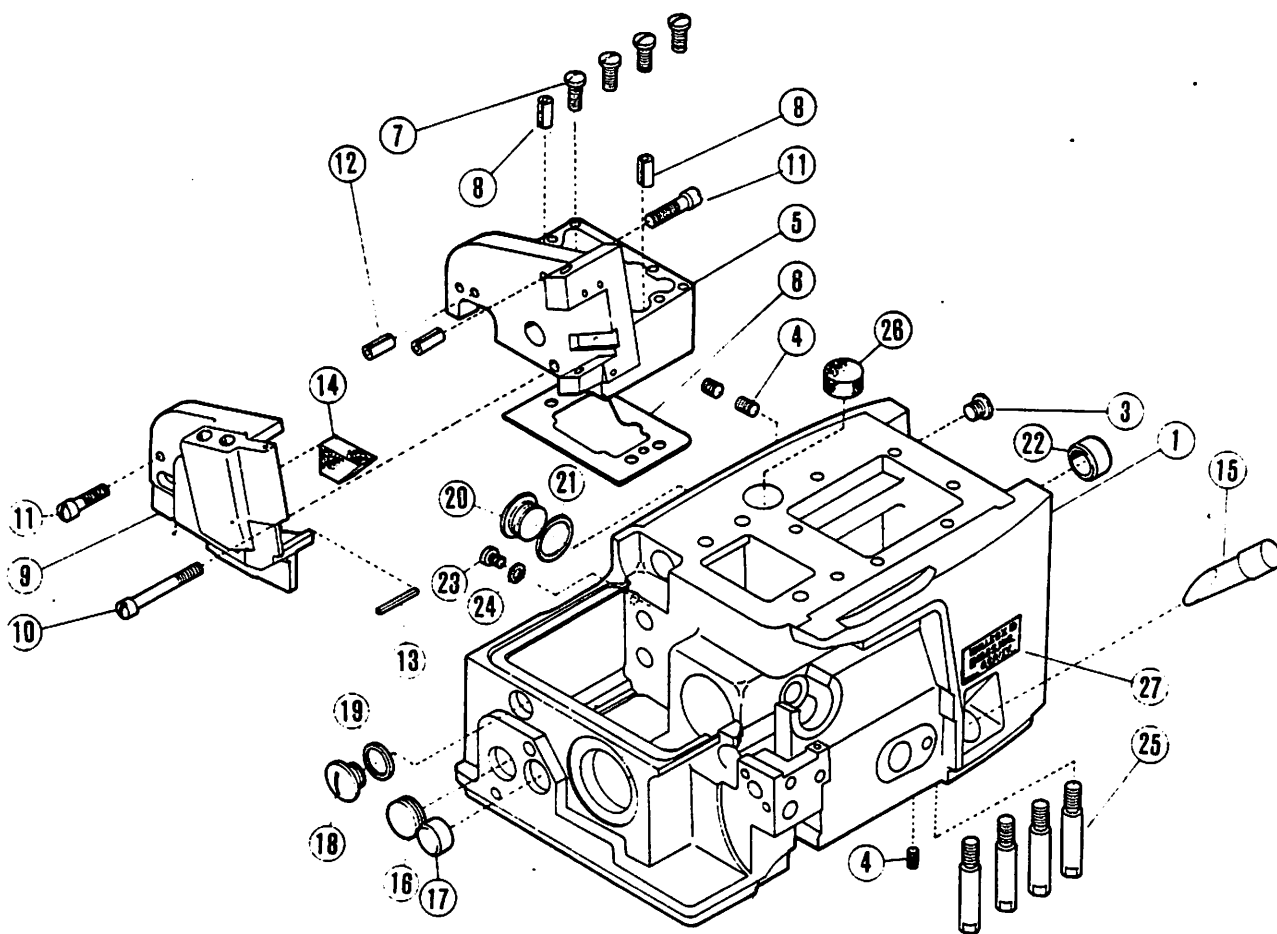
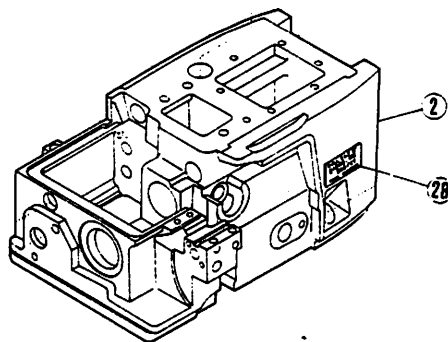

**503-516/IV
MACHINE BED FRAME**

REF. NO.	NEW PRODUCT CODE NO.	OLD NO.	DESCRIPTION	503/IV	
				504/IV 514/IV	515/IV 516/IV
1	323-508-007	204000B	Machine bed frame		x
2	323-508-004	204739	Machine bed frame	x	
3	323-600-359	5332	Machine bed frame oil hole plug screw	x	x
4	323-600-043	2022	Machine bed frame oil hole plug screw (3 used)	x	x
5	323-500-006	204622A	Machine arm (right)	x	x
6	323-663-207	204251	Machine arm (right) oil seal gasket	x	x
7	323-600-001	5078	Machine arm (right) screw (4 used)	x	x
8	323-620-001	201002	Machine arm (right) hinge pin (2 used)	x	x
9	323-500-004	204850	Machine arm (left)	x	x
10	323-600-327	5237	Machine arm (left) screw (long)	x	x
11	323-600-328	5163	Machine arm (left) screw (short) (2 used)	x	x
12	323-620-001	201002	Machine arm (left) hinge pin (2 used)	x	x
13	323-663-213	204277	Machine arm (left) oil shield	x	x
14	323-560-015	204849	Machine arm (left) dust shield	x	x
15	323-882-201	204003	Oil sight gauge	x	x
16	323-627-205	204004	Dead hole plug	x	x
17	323-627-014	205088	Dead hole plug	x	x
18	323-600-329	5179	Construction hole plug screw (small)	x	x
19	323-615-001	201006	Construction hole plug screw (small) washer	x	x
20	323-600-356	5313	Construction hole plug screw (large)	x	x
21	323-615-232	204448	Construction hole plug screw (large) washer	x	x
22	323-627-010	204828	Dead hole plug	x	x
23	323-600-359	5332	Screw driver hole plug screw	x	x
24	323-615-209	200138	Screw driver hole plug screw washer	x	x
25	323-620-242	204006	Machine bed bottom pin (4 used)	x	x
26	323-655-007	204794A	Machine bed oil filter	x	x
27	323-692-224	204334	Model plate for 515/IV-26		
28	323-692-017	204686	Model plate for 504/IV-45		

515-516/IV
(1) MAIN FRAME AND
MISCELLANEOUS COVERS

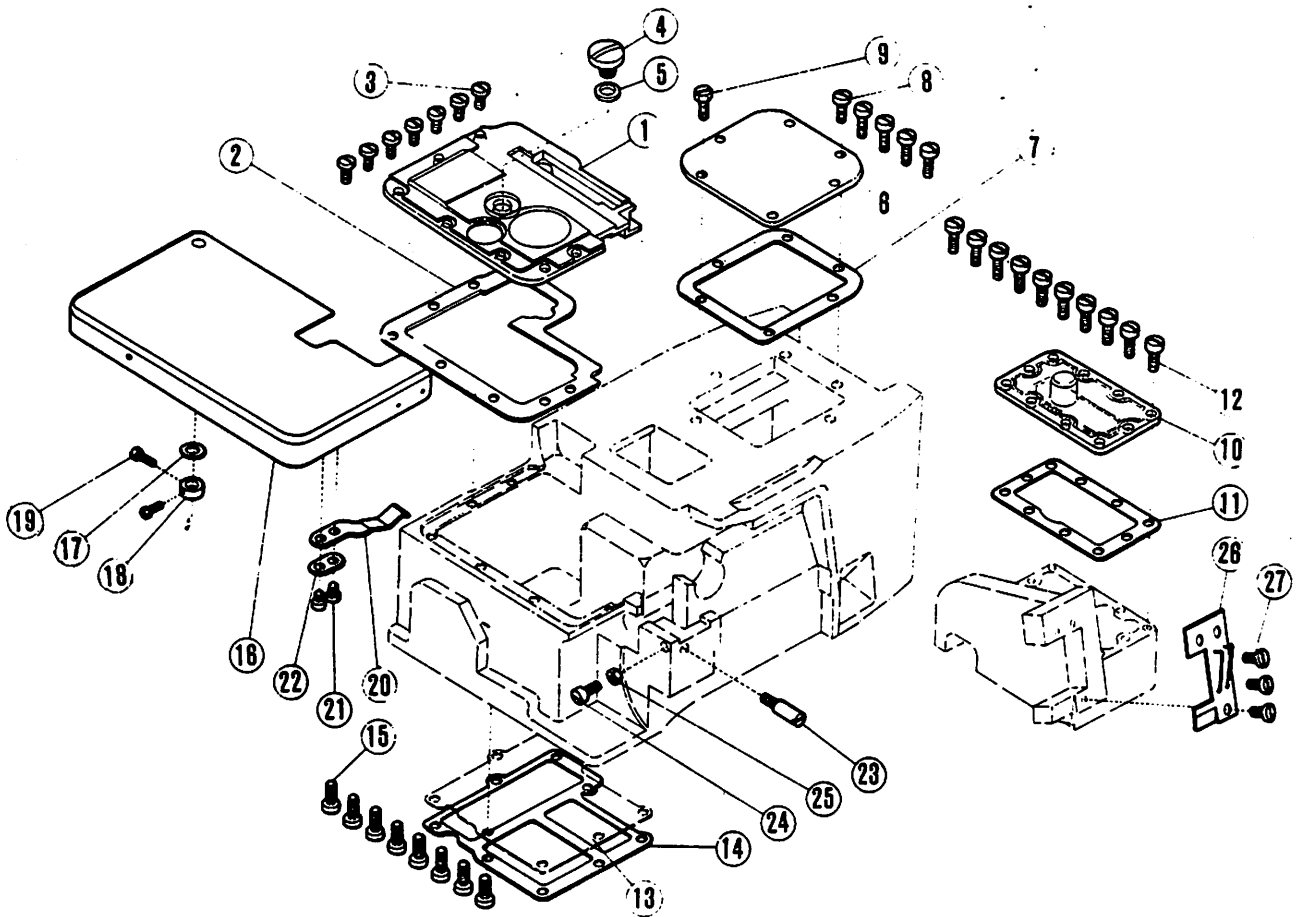

515-516/IV
(1) MAIN FRAME AND MISCELLANEOUS COVERS

<u>REF. NO.</u>	<u>NEW PRODUCT CODE NO.</u>	<u>OLD NO.</u>	<u>DESCRIPTION</u>
1	323-800-032	204842	Bedplate
2	323-663-010	204851	Bedplate gasket
3	323-600-014	4009-1	Bedplate screw (7 used)
4	323-600-354	5138B	Oil filler plug screw
5	323-615-229	202287A	Oil filler plug screw washer
6	323-510-247	204208	Machine bed cover
7	323-663-208	204209	Machine bed cover gasket
8	323-600-0	5117	Machine bed cover screw (round head) (5 used)
9	323-600-271	2193	Machine bed cover screw (hex. head)
10	323-510-265	204210A	Machine arm (right) cover plate
11	323-663-209	204211	Machine arm (right) cover plate gasket
12	323-600-057	5117	Machine arm (right) cover plate screw (10 used)
13	323-510-237	204212A	Machine bed bottom cover
14	323-800-034	204213A	Machine bed bottom cover plate
15	323-600-057	5117	Machine bed bottom cover plate screw (8 used)
16	323-802-210	204215	Cloth plate
17	323-615-201	202576	Cloth plate hinge stud thrust washer
18	323-680-001	201139	Cloth plate hinge stud thrust collar
19	323-600-013	5084	Cloth plate hinge stud thrust collar screw (2 used)
20	323-734-204	204218	Cloth plate lock spring
21	323-600-068	1216	Cloth plate lock spring screw (2 used)
22	323-615-015	200162A	Cloth plate lock spring screw washer
23	323-600-314	5232	Cloth plate lock spring latch
24	323-600-011	5002	Cloth plate stop screw
25	323-630-001	3044	Cloth plate stop screw nut
26	323-800-222	204325	Face plate
27	323-600-014	4009-1	Face plate screw (3 used)

515-516/IV
(2) MAIN FRAME AND
MISCELLANEOUS COVERS

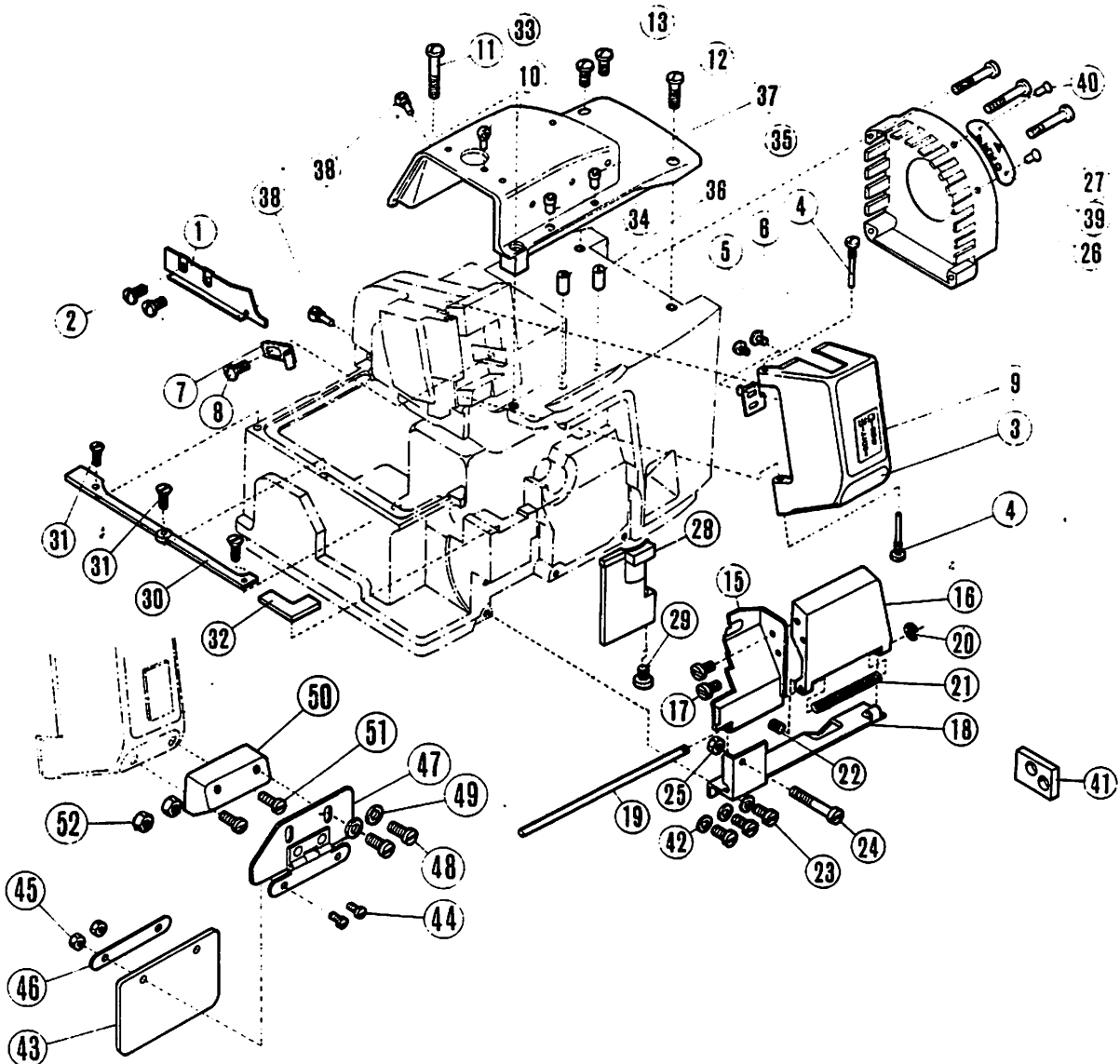

515-516/IV
(2) MAIN FRAME AND MISCELLANEOUS COVERS

REF. NO.	NEW PRODUCT CODE NO.	OLD NO.	DESCRIPTION
1	323-560-016	204848	Cloth plate fabric guard
2	323-600-014	4009-1	Cloth plate fabric guard screw (2 used)
3	323-510-051	208023	Needle bar cover
4	323-620-240	202653	Needle bar cover hinge pin (2 used)
5	323-641-201	202689	Needle bar cover lock spring
6	323-600-006	1234	Needle bar cover lock spring screw (2 used)
7	323-510-248	204223	Needle bar cover lock spring latch
8	323-600-014	4009-1	Needle bar cover lock spring latch screw
9	323-692-256	204450	Needle bar cover name plate
10	323-510-251	204224	Top cover
11	323-600-072	5094	Top cover screw (long)
12	323-600-038	5095	Top cover screw (medium)
13	323-600-057	5117	Top cover screw (short) (2 used)
14	323-510-054	208012	Front cover, complete with 208002, 208000, 208007, 208009, 200555, 208010, 1459 & 1189x2
15	323-510-050	208002	Front cover (left)
16	323-510-052	208000	Front cover (right)
17	323-600-301	1189	Front cover screw (2 used)
18	323-728-009	208007	Front cover hinge
19	323-622-004	208009	Front cover hinge pin
20	323-634-004	200555	Front cover hinge pin stop ring
21	323-640-015	208010	Front cover hinge spring
22	323-600-034	1459	Front cover hinge pin screw
23	323-600-068	1216	Front cover hinge screw (short) (3 used)
24	323-600-072	5094	Front cover hinge screw (long)
25	323-630-202	5137	Front cover hinge screw (long) nut
26	323-510-030	204650A	Oil cooler cover
27	323-600-072	5094	Oil cooler cover screw (3 used)
28	323-560-014	204799	Right looper lever oil shield
29	323-600-206	5147	Right looper lever oil shield screw
30	323-627-206	204242	Cloth plate rubber
31	323-600-251	5022	Cloth plate rubber screw (3 used)
32	323-627-207	204243	Cloth plate rubber plug
33	323-860-200	201048A	Right needle thread eyelet
34	323-639-225	201072A	Right looper thread tube
35	323-860-213	201048A-1	Right looper thread eyelet
36	323-639-225	201072A	Left looper thread tube
37	323-860-213	201048A-1	Left looper thread eyelet
38	323-860-200	201048A	Chainstitch looper thread eyelet (2 used)
39	323-891-002	204649	Stitch indicator
40	323-628-002	204871	Stitch indicator rivet (2 used)
41	323-800-026	204646	Front cover spacer
42	323-615-018	137906	Front cover hinge screw (short) washer (3 used)
43	323-561-018	204988	Eye guard, complete with parts of Ref. Nos 43-52
43	323-561-019	204924	Eye guard
44	323-600-073	2918	Eye guard screw (2 used)
45	323-630-009	5099	Eye guard screw nut (2 used)
46	323-615-032	204925	Eye guard screw nut washer
47	323-728-012	204922	Eye guard hinge
48	323-600-046	1170-3	Eye guard hinge screw (2 used)
49	323-615-013	200821	Eye guard hinge screw washer (2 used)
50	323-505-012	204982	Eye guard hinge base
51	323-600-227	5003	Eye guard hinge base screw (2 used)
52	323-630-009	5099	Eye guard hinge base screw nut (2 used)

503-514/IV
(1) MAIN FRAME AND MISCELLANEOUS
COVERS

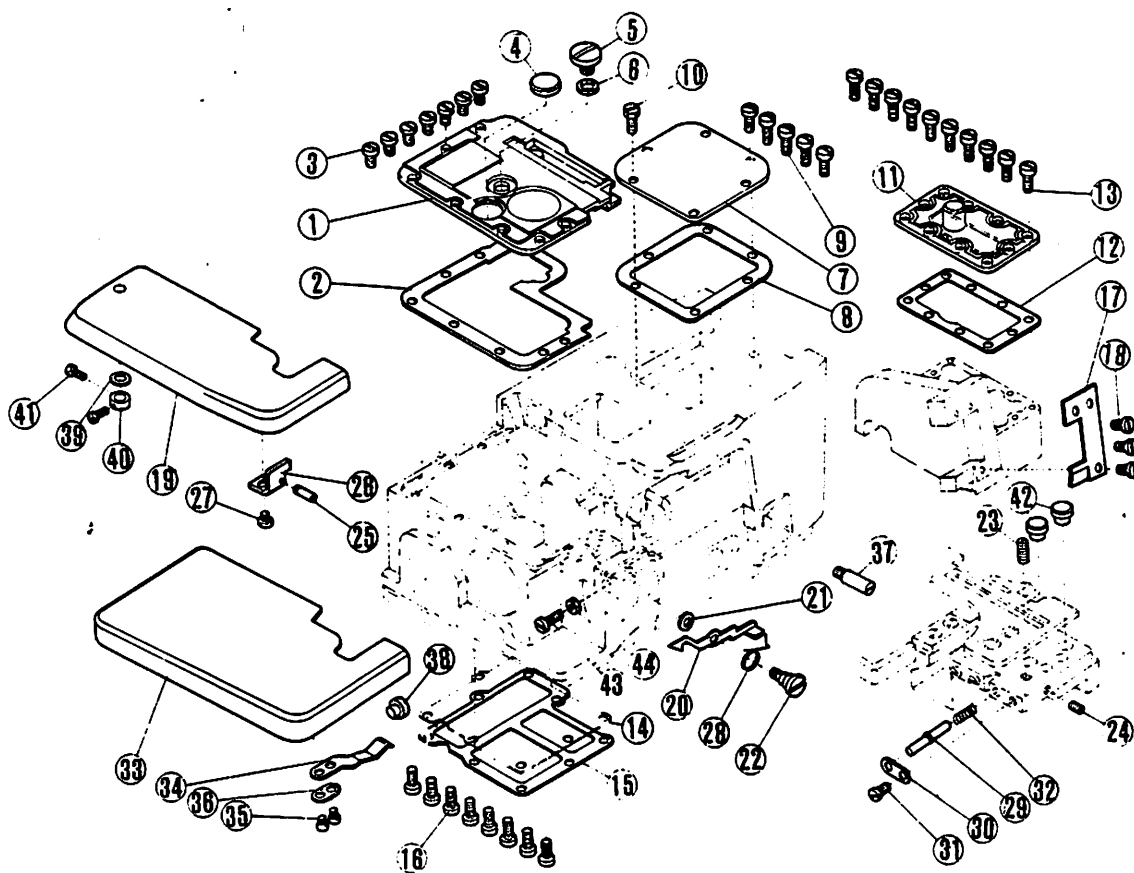

503-514/IV
(1) MAIN FRAME AND MISCELLANEOUS COVERS

REF. NO.	NEW PRODUCT CODE NO.	OLD NO.	DESCRIPTION
1	323-800-032	204842	Bedplate
2	323-663-010	204851	Bedplate gasket
3	323-600-014	4009-1	Bedplate screw (7 used)
4	323-627-009	204827	Cloth plate cushion plug (large)
5	323-600-354	5138B	Oil filler plug screw
6	323-615-229	202287A	Oil filler plug screw washer
7	323-510-247	204208	Machine bed cover
8	323-663-208	204209	Machine bed cover gasket
9	323-600-057	5117	Machine bed cover screw (round head) (5 used)
10	323-600-271	2193	Machine bed cover screw (hex. head)
11	323-510-265	204210A	Machine arm (right) cover plate
12	323-663-209	204211	Machine arm (right) cover plate gasket
13	323-600-057	5117	Machine arm (right) cover plate screw (10 used)
14	323-510-237	204212A	Machine bed bottom cover
15	323-800-034	204213A	Machine bed bottom cover plate
16	323-600-057	5117	Machine bed bottom cover plate screw (8 used)
17	323-800-223	202650	Face plate
18	323-600-014	4009-1	Face plate screw (3 used)
19	323-802-002	204740	Cloth plate (narrow) (used with parts of Ref. Nos. 20-32)
20	323-734-003	204742	Cloth plate latch
21	323-618-213	204118	Cloth plate latch spacer
22	323-600-099	5362	Cloth plate latch screw
23	323-600-069	1435	Cloth plate latch adjusting screw
24	323-600-034	1459	Cloth plate latch adjusting screw lock screw
25	323-620-014	204743	Cloth plate latch pin
26	323-740-019	204744	Cloth plate latch pin bracket
27	323-600-032	1202	Cloth plate latch pin bracket screw
28	323-640-007	204745	Cloth plate latch spring
29	323-620-015	204746	Cloth plate push pin
30	323-850-023	204747	Cloth plate push pin guide
31	323-600-015	5053	Cloth plate push pin guide screw
32	323-640-008	204748	Cloth plate push pin spring
33	323-802-003	204798	Cloth plate (wide) (used with parts of Ref. Nos. 34-38)
34	323-734-204	204218	Cloth plate lock spring
35	323-600-068	1216	Cloth plate lock spring screw (2 used)
36	323-615-014	200162	Cloth plate lock spring screw washer
37	323-600-314	5232	Cloth plate lock spring pin-screw
38	323-627-005	204749	Cloth plate cushion plug
39	323-615-201	202576	Cloth plate hinge stud thrust washer
40	323-680-001	201139	Cloth plate hinge stud thrust collar
41	323-600-013	5084	Cloth plate hinge stud thrust collar screw (2 used)
42	323-627-005	204749	Cloth plate cushion plug (small) (2 used)
43	323-600-057	5117	Cloth plate stop screw
44	323-630-001	3044	Cloth plate stop screw nut

503-514/IV
(2) MAIN FRAME AND
MISCELLANEOUS COVERS

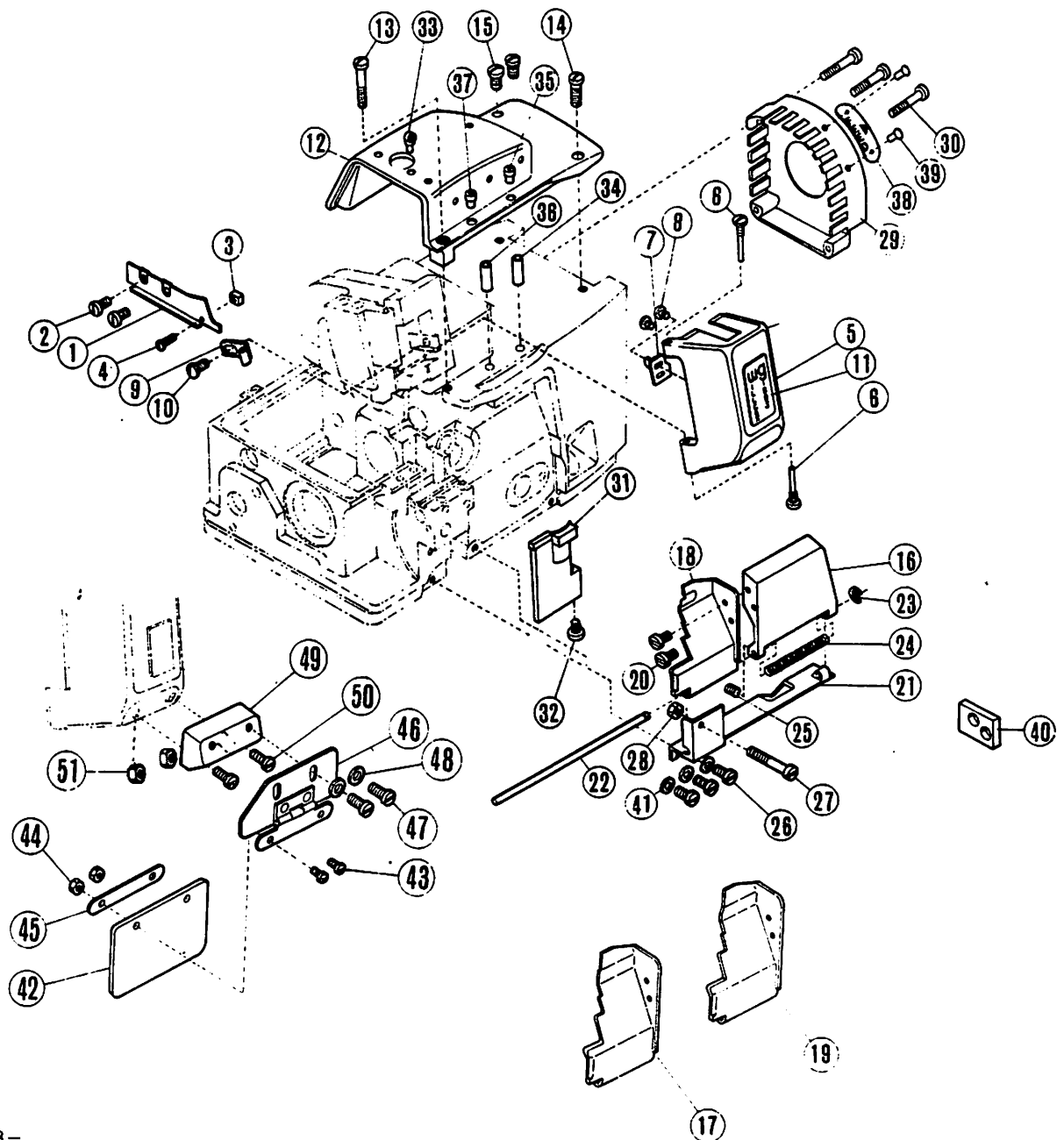

503-514/IV
(2) MAIN FRAME AND MISCELLANEOUS COVERS

REF. NO.	NEW PRODUCT CODE NO.	OLD NO.	DESCRIPTION
1	323-560-016	204848	Cloth plate fabric guard
2	323-600-014	4009-1	Cloth plate fabric guard screw (2 used)
3	323-646-003	204681	Cloth plate fabric guard spacer
4	323-600-229	2922	Cloth plate fabric guard spacer screw
5	323-510-051	208023	Needle bar cover
6	323-620-240	202653	Needle bar cover hinge pin (2 used)
7	323-641-201	202689	Needle bar cover lock spring
8	323-600-006	1234	Needle bar cover lock spring screw (2 used)
9	323-510-248	204223	Needle bar cover lock spring latch
10	323-600-014	4009-1	Needle bar cover lock spring latch screw
11	323-692-256	204450	Needle bar cover name plate
12	323-510-251	204224	Top cover
13	323-600-072	5094	Top cover screw (long)
14	323-600-038	5095	Top cover screw (medium)
15	323-600-057	5117	Top cover screw (short) (2 used)
16	323-510-052	208000	Front cover (right)
17	323-510-046	208003	Front cover (left) (all 1-needle machines and 2-needle 1.5mm & 2mm gauge machines)
18	323-510-053	208058	Front cover (left) (2-needle 2.5mm & 3mm gauge machines)
19	323-510-048	208005	Front cover (left) (7mm & 8mm gauge)
20	323-600-301	1189	Front cover screw (2 used)
21	323-728-009	208007	Front cover hinge
22	323-622-004	208009	Front cover hinge pin
23	323-634-004	200555	Front cover hinge pin stop ring
24	323-640-015	208010	Front cover hinge spring
25	323-600-034	1459	Front cover hinge pin screw
26	323-600-068	1216	Front cover hinge screw (short) (3 used)
27	323-600-072	5094	Front cover hinge screw (long)
28	323-630-202	5137	Front cover hinge screw (long) nut
29	323-510-030	204650A	Oil cooler cover
30	323-600-072	5094	Oil cooler cover screw (3 used)
31	323-560-014	204799	Right looper lever oil shield
32	323-600-206	5147	Right looper lever oil shield screw
33	323-860-200	201048A	Right needle thread eyelet
34	323-639-225	201072A	Right looper thread tube
35	323-860-213	201048A-1	Right looper thread eyelet
36	323-639-225	201072A	Left looper thread tube
37	323-860-213	201048A-1	Left looper thread eyelet
38	323-891-002	204649	Stitch indicator
39	323-628-002	204871	Stitch indicator rivet
40	323-800-026	204646	Front cover spacer
41	323-615-018	137906	Front cover hinge screw (short) washer (3 used)
	323-561-018	204988	Eye guard, complete with parts of Ref. Nos 42-51
42	323-561-019	204924	Eye guard
43	323-600-073	2918	Eye guard screw (2 used)
44	323-630-009	5099	Eye guard screw nut (2 used)
45	323-615-032	204925	Eye guard screw nut washer
46	323-728-012	204922	Eye guard hinge
47	323-600-046	1170-3	Eye guard hinge screw (2 used)
48	323-615-013	200821	Eye guard hinge screw washer (2 used)
49	323-505-012	204982	Eye guard hinge base
50	323-600-227	5003	Eye guard hinge base screw (2 used)
51	323-630-009	5099	Eye guard hinge base screw nut (2 used)

503-516/IV
CRANKSHAFT MECHANISM

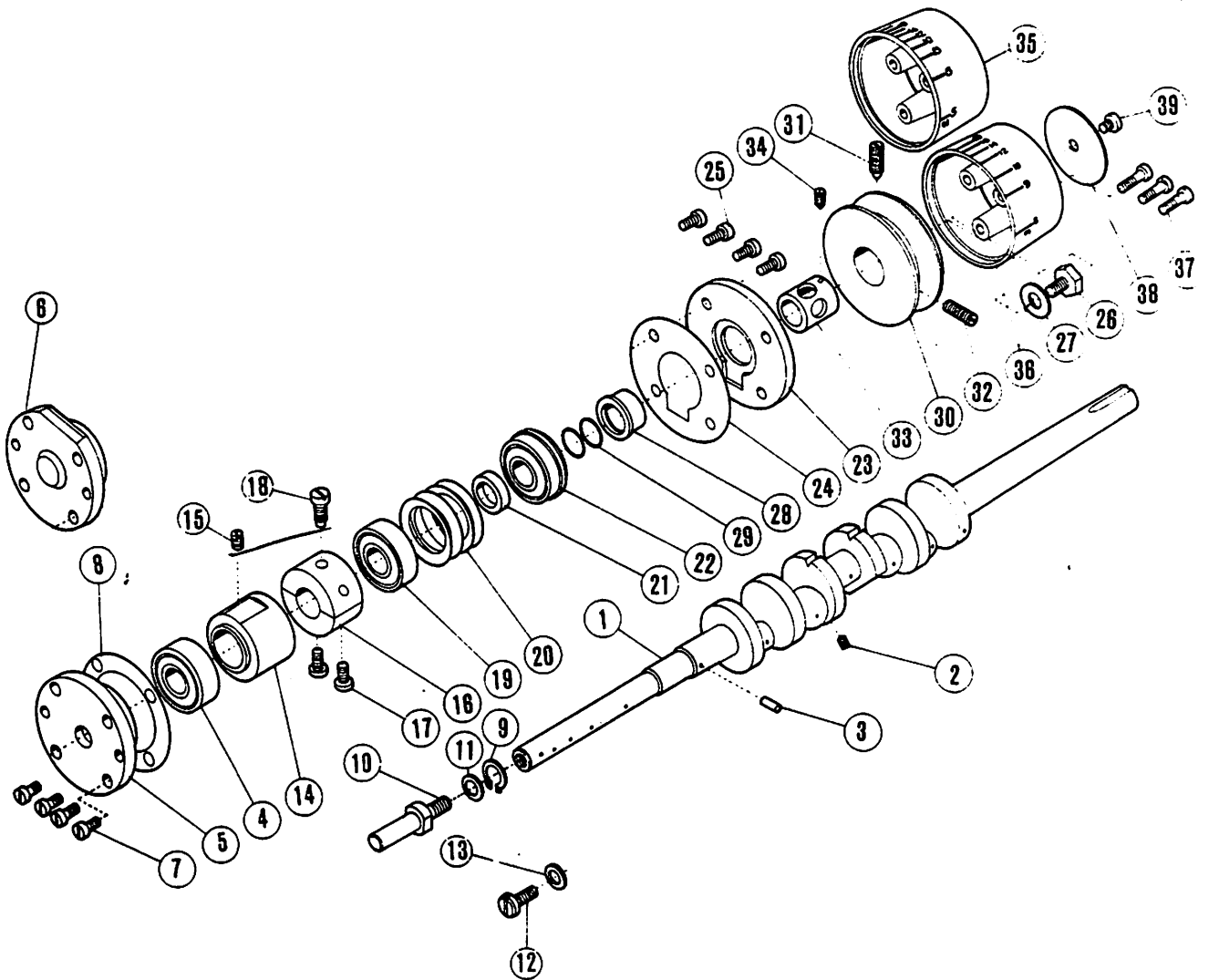
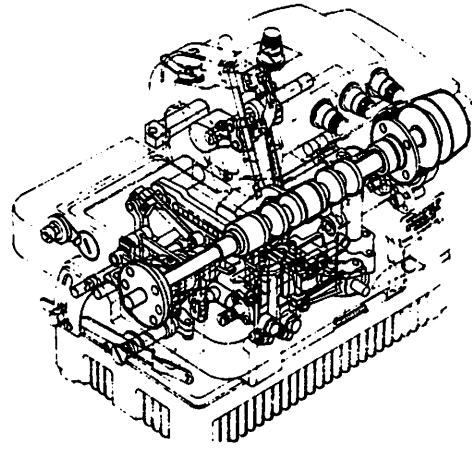

**503-516/IV
CRANKSHAFT MECHANISM**

REF. NO.	NEW PRODUCT CODE NO.	OLD NO.	DESCRIPTION	503/IV	515/IV
				504/IV 514/IV	516/IV
1	323-540-015	204733	Crankshaft	x	x
2	323-600-344	5315	Crankshaft oil plug screw	x	x
3	323-653-003	202081	Crankshaft oil wick	x	x
4	323-671-200	204010	Crankshaft ball bearing (left)	x	x
5	323-515-004	204881	Crankshaft ball bearing (left) housing		x
6	323-515-002	204737	Crankshaft ball bearing (left) housing	x	
7	323-600-245	5136	Crankshaft ball bearing (left) housing screw (4 used)	x	x
8	323-663-205	204319	Crankshaft ball bearing (left) housing gasket	x	x
9	323-633-002	204734	Crankshaft ball bearing (left) retaining ring	x	x
10	323-758-003	204873	Crankshaft extension		x
11	323-615-233	204520	Crankshaft extension washer		x
12	323-600-097	5361	Crankshaft ball bearing (left) screw	x	
13	323-615-233	204520	Crankshaft ball bearing (left) screw washer	x	
14	323-676-243	204014	Crankshaft bushing	x	x
15	323-600-043	2022	Crankshaft bushing screw	x	x
16	323-676-232	204016	Crankshaft bushing (center), complete with 1174x2	x	x
17	323-600-027	1174	Crankshaft bushing (center) assembling screw (2 used)	x	x
18	323-600-293	5240	Crankshaft bushing (center) screw	x	x
19	323-671-001	201523A	Crankshaft ball bearing (center)	x	x
20	323-615-217	204018	Crankshaft ball bearing (center) washer (4 used)	x	x
21	323-646-001	204019A	Crankshaft ball bearing (center) spacer	x	x
22	323-671-002	204020A	Crankshaft ball bearing (right)	x	x
23	323-800-224	204021	Crankshaft ball bearing (right) plate	x	x
24	323-626-202	204022	Crankshaft ball bearing (right) plate gasket	x	x
25	323-600-057	5117	Crankshaft ball bearing (right) plate screw (4 used)	x	x
26	323-600-294	5238	Crankshaft ball bearing (right) screw	x	x
27	323-615-221	204023	Crankshaft ball bearing (right) screw washer	x	x
28	323-680-204	204024	Crankshaft oil seal collar	x	x
29	323-632-001	201022	Crankshaft oil seal collar "O" ring (2 used)	x	x
30	323-546-203	204025	Machine pulley	x	x
31	323-600-008	5080	Machine pulley position screw	x	x
32	323-600-009	5081	Machine pulley screw	x	x
33	323-546-204	204026	Machine pulley collar	x	x
34	323-600-295	5267	Machine pulley collar screw	x	x
35	323-780-006	204658	Machine pulley cap - 2:1 diff. feed ratio	x	x
36	323-780-005	204648	Machine pulley cap - 3:1 diff. feed ratio	x	x
37	323-600-010	5010	Machine pulley cap screw (3 used)	x	x
38	323-510-245	204028	Machine pulley cap name plate	x	x
39	323-600-209	5214	Machine pulley cap name plate screw	x	x

503-516/IV
(1) NEEDLE DRIVE MECHANISM

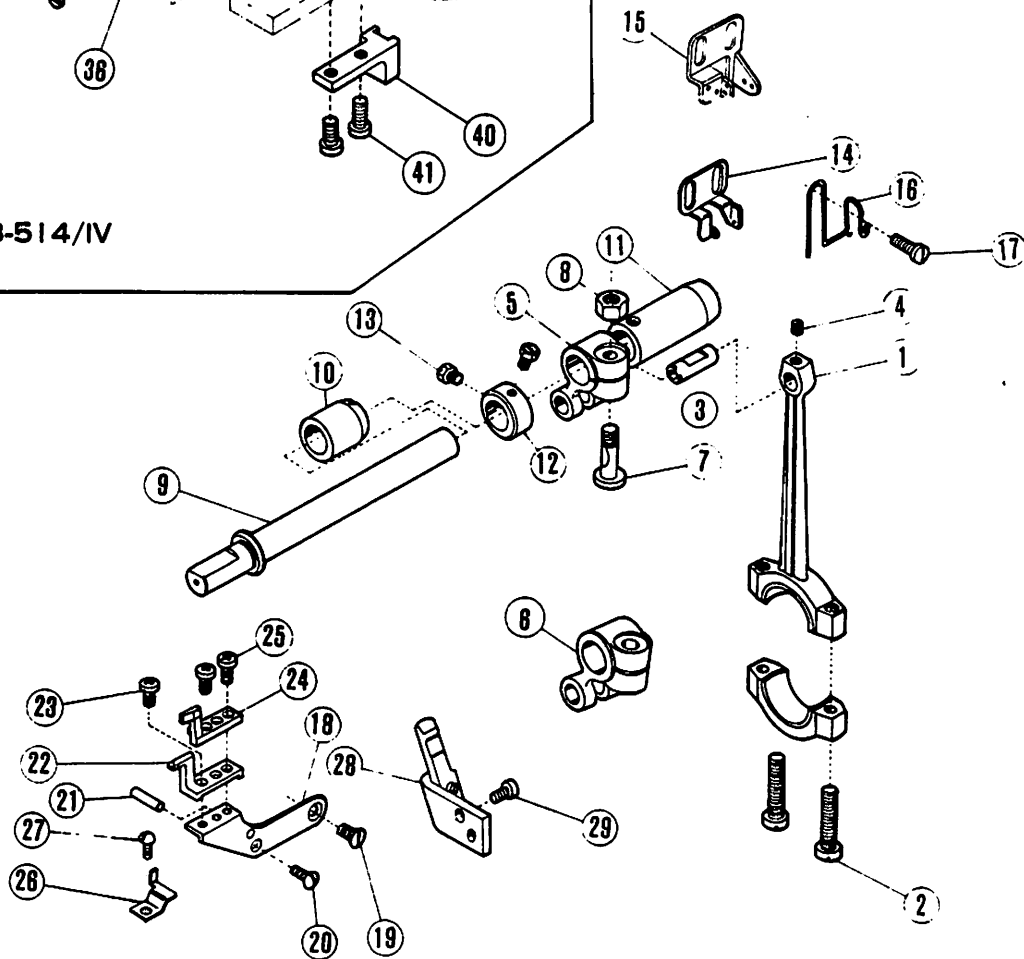
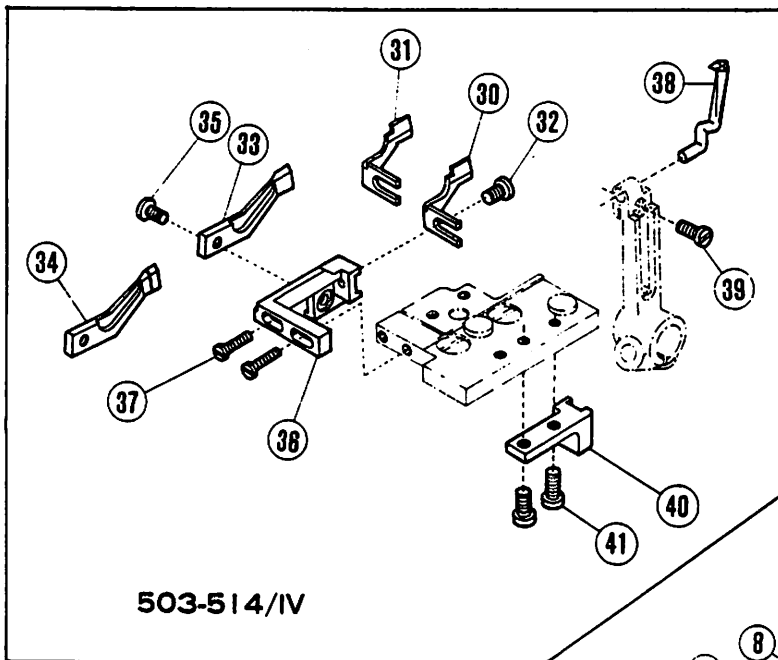
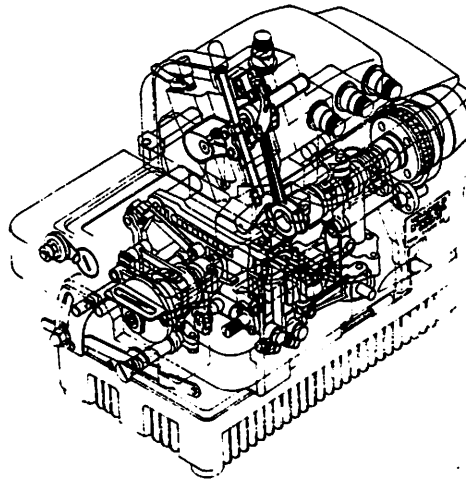

**503-516/IV
(1) NEEDLE DRIVE MECHANISM**

REF. NO.	NEW PRODUCT CODE NO.	OLD NO.	DESCRIPTION	503/IV	
				504/IV 514/IV	515/IV 516/IV
1	323-535-205	204029	Needle bar drive connection	x	x
2	323-600-296	5233	Needle bar drive connection cap screw (2 used)	x	x
3	323-620-237	202711A	Needle bar drive connection pin	x	x
4	323-600-297	5234	Needle bar drive connection pin screw	x	x
5	323-576-004	201360A	Needle bar drive crank (right)		
(515-516/IV – except 515-516/IV-51 & -52) (503-504/IV – except 504/IV-S-10)					
6	323-576-005	201441A	Needle bar drive crank (right)		
7	323-600-040	5087	Needle bar drive crank (right) clamp screw	x	x
(514/IV, 515-516/IV-51 & -52, 504/IV-S-10)					
8	323-630-005	5181	Needle bar drive crank (right) clamp screw nut	x	x
9	323-540-232	204031	Needle bar drive shaft	x	x
10	323-676-233	204032	Needle bar drive shaft bushing (left)	x	x
11	323-676-028	204033A	Needle bar drive shaft bushing (right)	x	x
12	323-618-006	201117	Needle bar drive shaft thrust collar	x	x
13	323-600-013	5084	Needle bar drive shaft thrust collar screw (2 used)	x	x
14	323-851-213	204276	Needle thread guide		x
15	323-851-222	202704	Needle thread guide	x	
16	323-851-215	204046	Needle thread guide wire	x	x
17	323-600-014	4009-1	Needle thread guide wire screw	x	x
18	323-740-023	204783	Needle guard bracket		x
19	323-600-228	5061	Needle guard bracket screw (large)		x
20	323-600-302	5227	Needle guard bracket screw (small)		x
21	323-639-019	204657	Right looper thread tube (left)		x
22	*323-561-013	204781	Needle guard (rear), for right needle		x
23	323-600-255	5012	Needle guard (rear) screw		x
24	*323-561-014	204782	Needle guard (front), for right needle		x
25	323-600-256	5029	Needle guard (front) screw (2 used)		x
26	*323-561-xxx		Needle guard (front), for left needle		x
27	323-600-302	5227	Needle guard (front) screw		x
28	*323-561-xxx		Needle guard (rear), for left needle		x
29	323-600-021	1206	Needle guard (rear) screw		x
30	*323-561-xxx		Needle guard (front) – 503-504/IV		
31	*323-561-xxx		Needle guard (front) – 514/IV		
32	323-600-021	1206	Needle guard (front) screw	x	
33	*323-561-xxx		Needle guard (rear) – 503-504/IV		
34	*323-561-xxx		Needle guard (rear) – 514/IV		
35	323-600-021	1206	Needle guard (rear) screw	x	
36	323-740-018	204636	Needle guard bracket	x	
37	323-600-027	1174	Needle guard bracket screw (2 used)	x	
38	323-561-017	204884	Movable type needle guard – optional item (514/IV)		
39	323-600-245	5136	Movable type needle guard screw		
40	323-740-037	204762	Edge guide holder bracket base	x	
41	323-600-019	1175-3	Edge guide holder bracket base screw (2 used)	x	

*See Organization Chart

503-516/IV
 (2) NEEDLE DRIVE MECHANISM

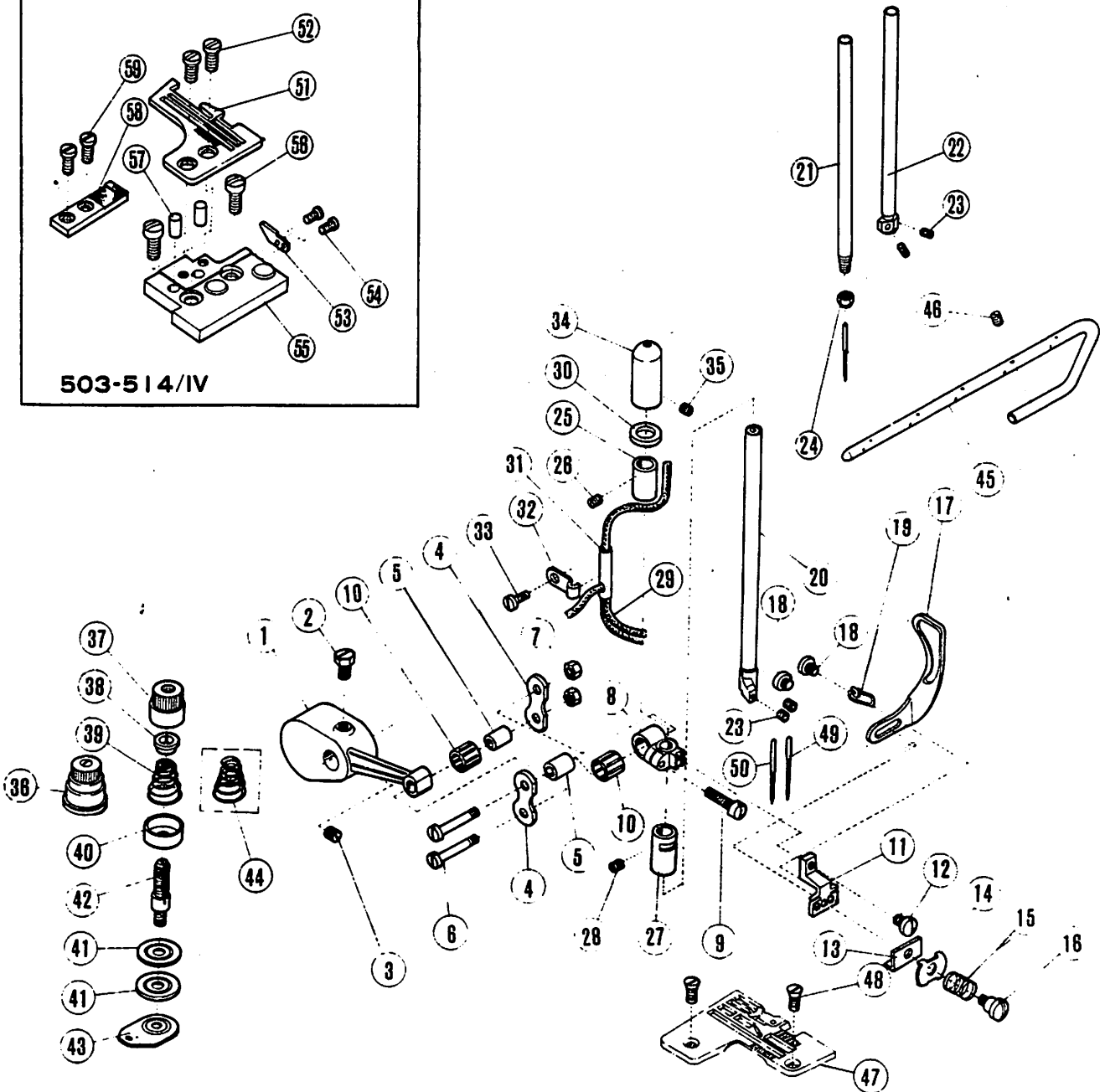
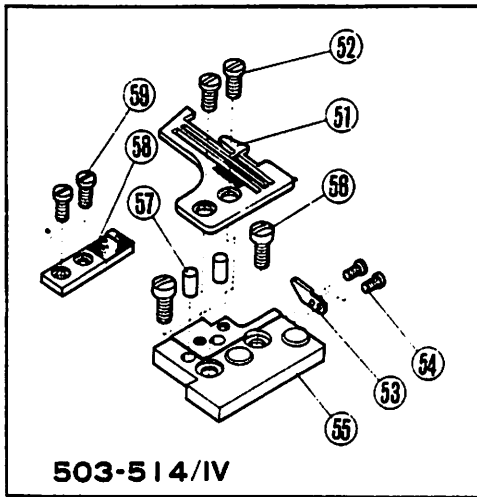
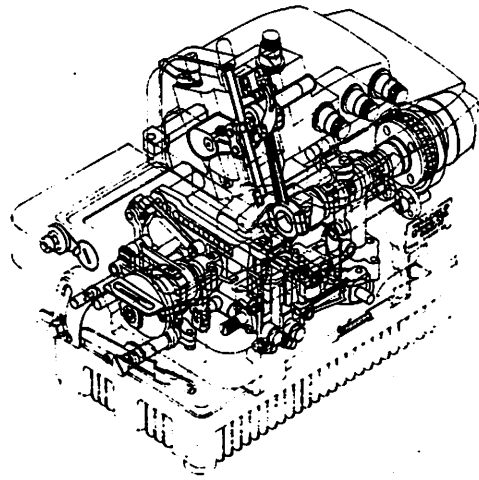

**503-516/IV
(2) NEEDLE DRIVE MECHANISM**

REF. NO.	NEW PRODUCT CODE NO.	OLD NO.	DESCRIPTION	503/IV 504/IV 514/IV	515/IV 516/IV
1	323-576-218	202607	Needle bar drive crank (left)	X	X
2	323-600-022	2022-4	Needle bar drive crank (left) screw (with head)	X	X
3	323-600-043	2022	Needle bar drive crank (left) screw	X	X
4	323-730-005	204628	Needle bar connecting link (2 used)	X	X
5	323-676-244	202609	Needle bar connecting link bushing (2 used)	X	X
6	323-600-299	5154	Needle bar connecting link bushing screw (2 used)	X	X
7	323-630-009	5099	Needle bar connecting link bushing screw nut (2 used)	X	X
8	323-740-218	202610	Needle bar connecting bracket	X	X
9	323-600-046	1170-3	Needle bar connecting bracket screw	X	X
10	323-670-200	202611	Needle bar connecting bracket bearing	X	X
11	323-740-016	202705A	Needle thread retainer bracket	X	X
12	323-600-091	5359	Needle thread retainer bracket screw	X	X
13	323-850-021	202495	Needle thread retainer guide spacer	X	X
14	323-850-221	200041	Needle thread retainer guide	X	X
15	323-640-203	200205	Needle thread retainer spring	X	X
16	323-600-224	9070-2	Needle thread retainer spring screw	X	X
17	323-866-214	202706A	Needle thread takeup	X	X
18	323-600-300	5299	Needle thread takeup screw (2 used)	X	X
19	323-851-212	204235	Needle thread guide wire	X	X
20	*323-843-xxx		Needle bar	X	X
21	*323-843-xxx		Needle bar	X	
22	*323-843-xxx		Needle bar	X	
23	323-600-341	5292	Needle clamp screw (2 used)	X	X
24	323-630-213	3119	Needle clamp nut	X	
25	323-676-025	204625A	Needle bar bushing (upper)	X	X
26	323-600-012	1457	Needle bar bushing (upper) screw	X	X
27	323-676-263	204627A	Needle bar bushing (lower)	X	X
28	323-600-012	1457	Needle bar bushing (lower) screw	X	X
29	323-653-005	202176	Needle bar bushing oil wick	X	X
30	323-686-009	204626	Needle bar bushing oil wick clamp	X	X
31	323-638-200	201436	Needle bar bushing oil wick tube	X	X
32	323-686-200	201437	Needle bar bushing oil wick tube clamp	X	X
33	323-600-039	5113	Needle bar bushing oil wick tube clamp screw	X	X
34	323-510-240	202615	Needle bar cap cover	X	X
35	323-600-012	1457	Needle bar cap cover screw	X	X
36	323-900-200	202478	Needle thread tension, complete with 201035A, 202278, 201037, 201039, 201482x2 & 5082A (for 3-thread overlock stitch)	X	X
37	323-630-200	201035A	Needle thread tension nut	X	X
38	323-676-202	202278	Needle thread tension spring bushing	X	X
39	323-642-001	201037	Needle thread tension spring (heavy)	X	X
40	323-780-002	201039	Needle thread tension spring cup	X	X
41	323-613-001	201482	Needle thread tension disc (2 used)	X	X
42	323-604-201	5082A	Needle thread tension post	X	X
43	323-800-215	202849	Needle thread tension guide	X	X
	323-900-201	202479	Needle thread tension, complete with 201035A, 202278, 201068, 201039, 201482x2 & 5082A (for 2-thread overlock stitch)		
44	323-642-002	201068	Needle thread tension spring (light)	X	X
45	323-851-216	204045	Top cover thread guide bar	X	X
46	323-600-303	5185	Top cover thread guide bar screw	X	X
47	*323-801-xxx		Needle plate		X
48	323-600-075	1732	Needle plate screw (2 used)		X
49	*		Needle (right)	X	X
50	*		Needle (left)		X
51	*323-801-xxx		Needle plate	X	
52	323-600-014	4009-1	Needle plate screw (2 used)	X	
53	323-649-003	204631	Needle plate key	X	
54	323-600-304	5239	Needle plate key screw (2 used)	X	
55	323-740-017	204750	Needle plate bracket	X	
56	323-600-098	5357	Needle plate bracket screw (2 used)	X	
57	323-620-017	204630	Needle plate bracket guide pin (2 used)	X	
58	323-756-003	204632	Needle plate support	X	
59	323-600-257	5091	Needle plate support screw (2 used)	X	

*See Organization Chart

**503-516/IV
RIGHT LOOPER DRIVE MECHANISM**

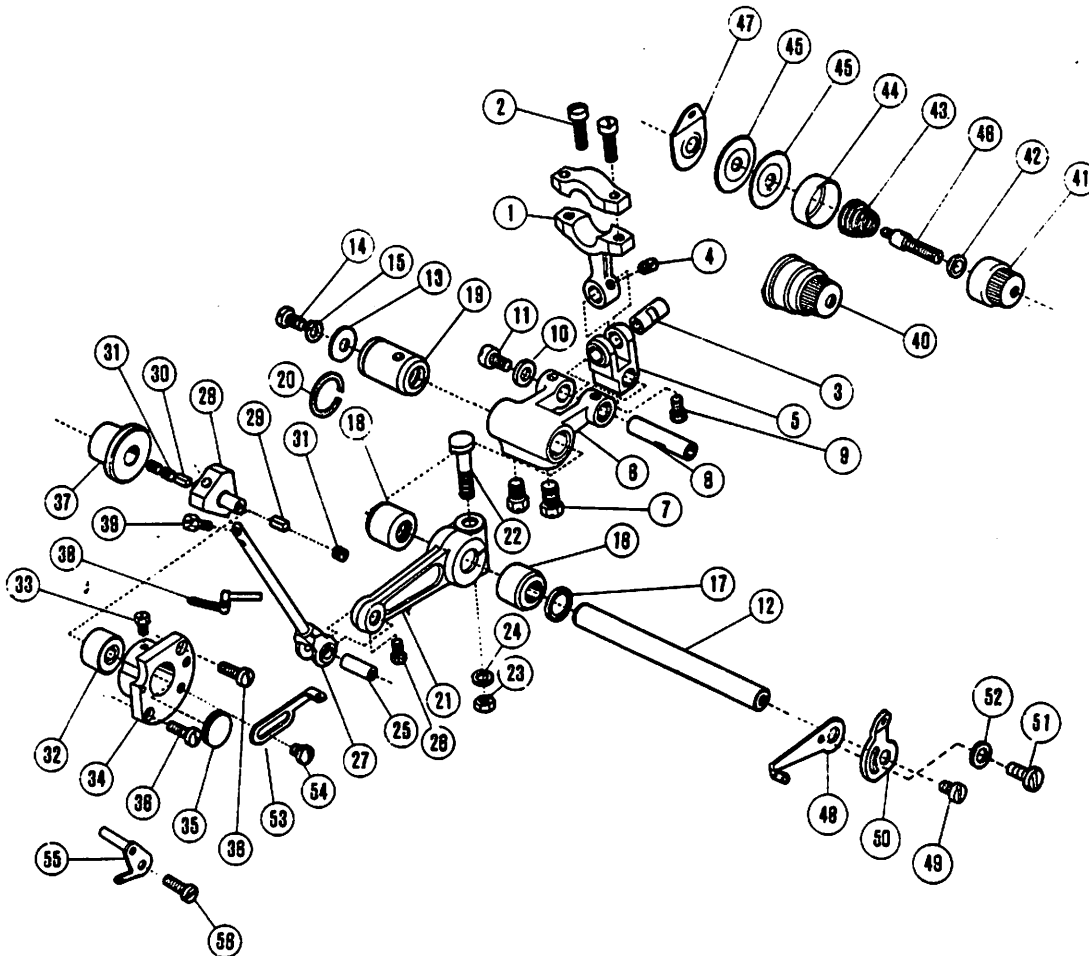
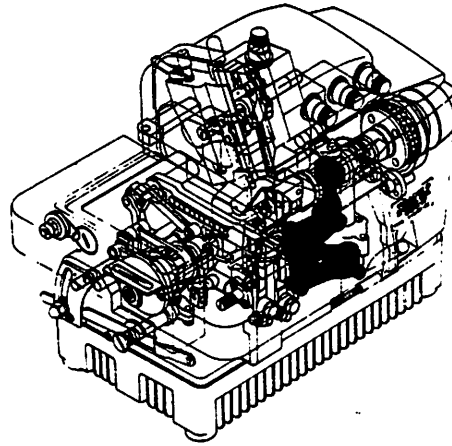

**503-516/IV
RIGHT LOOPER DRIVE MECHANISM**

REF. NO.	NEW PRODUCT CODE NO.	OLD NO.	DESCRIPTION	503/IV	
				504/IV 514/IV	515/IV 516/IV
1	323-730-208	204292	Right looper drive connection		
2	323-600-056	2213-1	Right looper drive connection cap screw (2 used)	x	x
3	323-620-237	20271-1A	Right looper drive crank pin	x	x
4	323-600-012	1457	Right looper drive crank pin screw	x	x
5	323-730-209	202709A	Right looper drive connecting link	x	x
6	323-576-217	204332	Right looper drive crank	x	x
7	323-600-022	2022-4	Right looper drive crank screw (2 used)	x	x
8	323-620-238	202712A	Right looper drive crank pin	x	x
9	323-600-013	5084	Right looper drive crank pin screw	x	x
10	323-615-218	202757	Right looper drive crank pin thrust washer	x	x
11	323-600-068	1216	Right looper drive crank pin thrust washer screw	x	x
12	323-540-228	204069A	Right looper lever shaft	x	x
13	323-618-210	204311	Right looper lever shaft thrust washer	x	x
14	323-600-271	2193	Right looper lever shaft thrust washer screw	x	x
15	323-617-200	202286	Right looper lever shaft thrust washer screw washer	x	x
16	323-676-234	204050A	Right looper lever shaft bushing (front)	x	x
17	323-626-201	204052A	Right looper lever shaft bushing (front) oil seal	x	x
18	323-676-236	204081	Right looper lever shaft bushing (center)	x	x
19	323-676-262	204437	Right looper lever shaft bushing (rear), complete with 204438	x	x
20	323-632-203	204438	Right looper lever shaft bushing (rear) stop ring	x	x
21	323-525-229	204055A	Right looper lever crank	x	x
22	323-630-304	5239	Right looper lever crank clamp screw	x	x
23	323-600-225	5286	Right looper lever crank clamp screw nut	x	x
24	323-617-204	202045	Right looper lever crank clamp screw nut washer	x	x
25	323-620-237	202711A	Right looper lever crank pin	x	x
26	323-600-013	5084	Right looper lever crank pin screw	x	x
27	323-530-224	204057A	Right looper lever	x	x
28	323-851-009	204732	Right looper lever guide	x	x
29	323-653-208	204273	Right looper lever guide oil wick (long)	x	x
30	323-653-209	204274	Right looper lever guide oil wick (short)	x	x
31	323-600-041	1457-1	Right looper lever guide oil plug screw (3 used)	x	x
	323-676-029	204854	Right looper lever guide bushing (front) housing, complete with 204059, 5084 & 204060	x	x
32	323-676-248	204059	Right looper lever guide bushing (front)	x	x
33	323-600-013	5084	Right looper lever guide bushing (front) screw	x	x
34	323-515-202	204060	Right looper lever guide bushing (front) housing	x	x
35	323-627-205	204004	Right looper lever guide bushing (front) housing cap	x	x
36	323-600-002	1175-2	Right looper lever guide bushing (front) housing screw (2 used)	x	x
37	323-676-249	204061	Right looper lever guide bushing (rear)	x	x
38	* 323-810-xxx		Right looper	x	x
39	323-600-291	5220	Right looper screw	x	x
40	323-900-202	202480	Right looper thread tension, complete with 201035A, 202278, 201086, 201039, 201482x2 & 5082A	x	x
41	323-630-200	201035A	Right looper thread tension nut	x	x
42	323-676-202	202278	Right looper thread tension spring bushing	x	x
43	323-642-003	201086	Right looper thread tension spring (middle)	x	x
44	323-780-002	201039	Right looper thread tension spring cup	x	x
45	323-613-001	201482	Right looper thread tension disc (2 used)	x	x
46	323-604-201	5082A	Right looper thread tension post	x	x
47	323-800-215	202849	Right looper thread tension guide	x	x
48	323-866-011	204063A	Right looper thread takeup (large)	x	x
49	323-600-259	2902	Right looper thread takeup (large) screw	x	x
50	323-866-013	204902	Right looper thread takeup (small)	x	x
51	323-600-026	2921	Right looper thread takeup (small) screw	x	x
52	323-615-216	202875	Right looper thread takeup (small) screw washer	x	x
53	323-851-018	204905	Right looper thread guide	x	x
54	323-600-074	2905	Right looper thread guide screw	x	x
55	323-851-019	204903	Looper thread guide	x	
56	323-600-255	5012	Looper thread guide screw	x	

*See Organization Chart

503-516/IV
LEFT LOOPER DRIVE MECHANISM

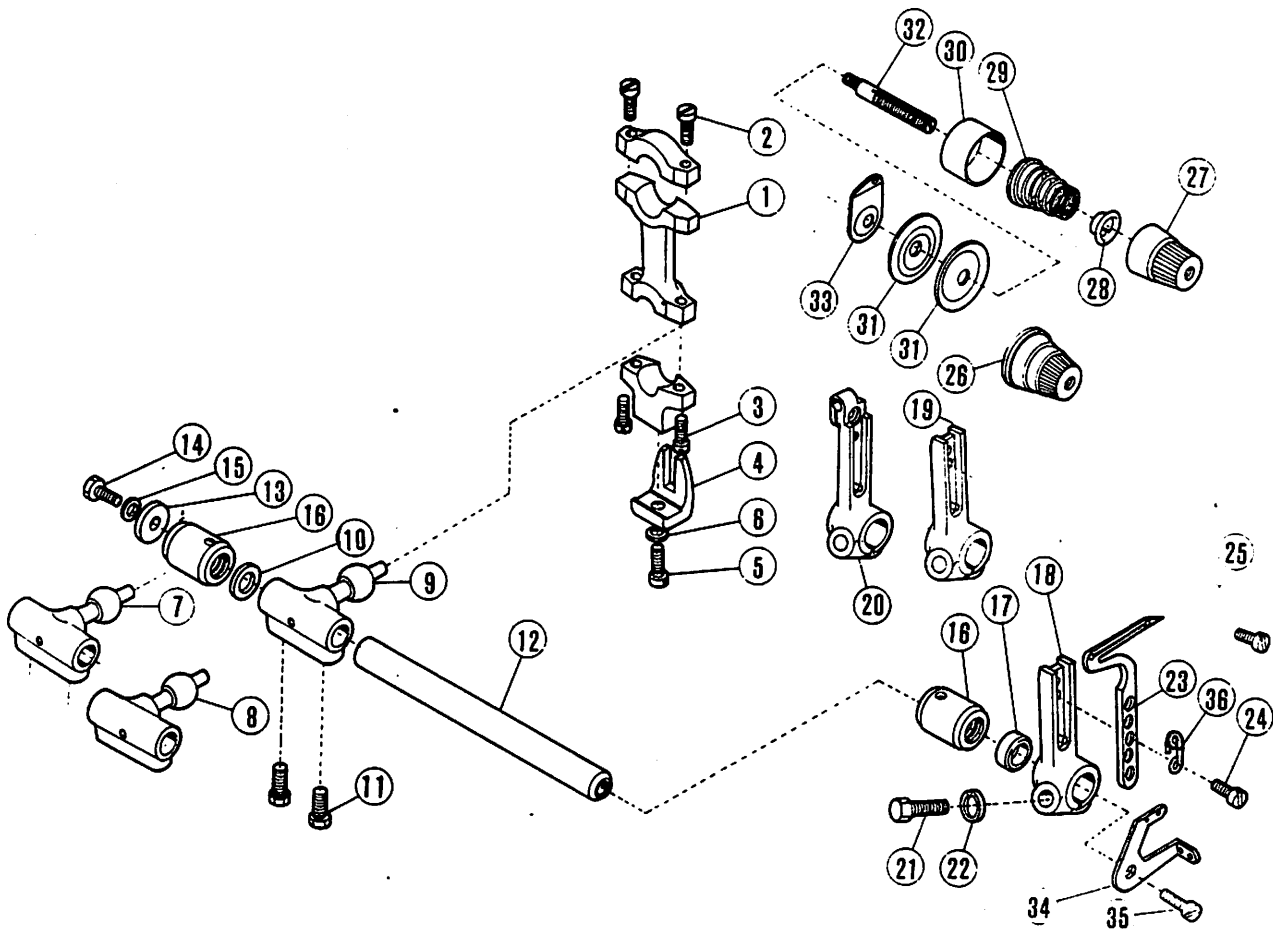
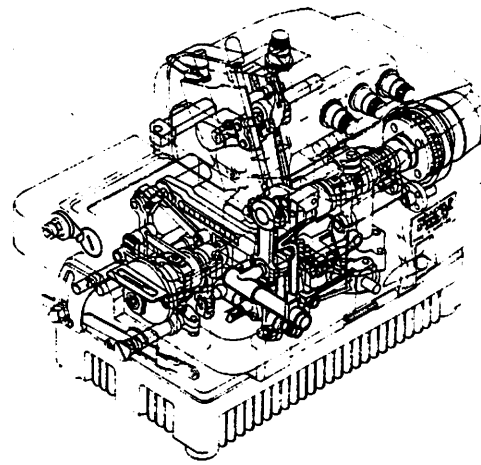

**503-516/IV
LEFT LOOPER DRIVE MECHANISM**

REF. NO	NEW PRODUCT CODE NO.	OLD NO.	DESCRIPTION	503/IV	
				504/IV 514/IV	515/IV 516/IV
1	323-525-230	204047	Left looper drive connection	x	x
2	323-600-056	2213-1	Left looper drive connection cap screw (large) (2 used)	x	x
3	323-600-020	1170-1	Left looper drive connection cap screw (small) (2 used)	x	x
4	323-850-200	201074A	Left looper drive connection guide	x	x
5	323-600-200	1156	Left looper drive connection guide screw	x	x
6	323-617-200	202286	Left looper drive connection guide screw washer	x	x
7	323-576-006	204787	Left looper drive crank (503-504/IV – except 504/IV-S-10)		
8	323-576-007	204788	Left looper drive crank (514/IV, 504/IV-S-10)		
9	323-576-213	204048A	Left looper drive crank (515-516/IV)		x
10	323-618-010	204789	Left looper drive crank thrust washer	x	x
11	323-600-022	2022-4	Left looper drive crank screw (2 used)	x	x
12	323-540-228	204069A	Left looper lever shaft	x	x
13	323-618-210	204311	Left looper lever shaft thrust washer	x	x
14	323-600-271	2193	Left looper lever shaft thrust washer screw	x	x
15	323-617-200	202286	Left looper lever shaft thrust washer screw washer	x	x
16	323-676-235	204054	Left looper lever shaft bushing (2 used)	x	x
17	323-626-201	204052A	Left looper lever shaft bushing oil seal	x	x
18	323-530-225	204071	Left looper lever		x
19	323-530-010	204664	Left looper lever	x	
20	323-530-017	204853	Left looper lever – optional item. used with movable type needle guard #204884		
21	323-600-306	5284	Left looper lever clamp screw	x	x
22	323-616-200	204293	Left looper lever clamp screw washer	x	x
23	* 323-810-xxx		Left looper		
24	323-600-301	1189	Left looper screw	x	
25	323-600-019	1175-3	Left looper screw		x
26	323-900-202	202480	Left looper thread tension, complete with 201035A 202278, 201086, 201039, 201482x2 & 5082A	x	x
27	323-630-200	201035A	Left looper thread tension nut	x	x
28	323-676-202	202278	Left looper thread tension spring bushing	x	x
29	323-642-003	201086	Left looper thread tension spring (middle)	x	x
30	323-780-002	201039	Left looper thread tension spring cup	x	x
31	323-613-001	201482	Left looper thread tension disc (2 used)	x	x
32	323-604-201	5082A	Left looper thread tension post	x	x
33	323-800-215	202849	Left looper thread tension guide	x	x
34	323-866-012	204901	Left looper thread takeup	x	x
35	323-600-259	2902	Left looper thread takeup screw	x	x
36	323-851-217	193174	Left looper thread guide wire	x	x

*See Organization Chart

515-516/IV
(1) CHAINSTITCH LOOPER DRIVE
MECHANISM

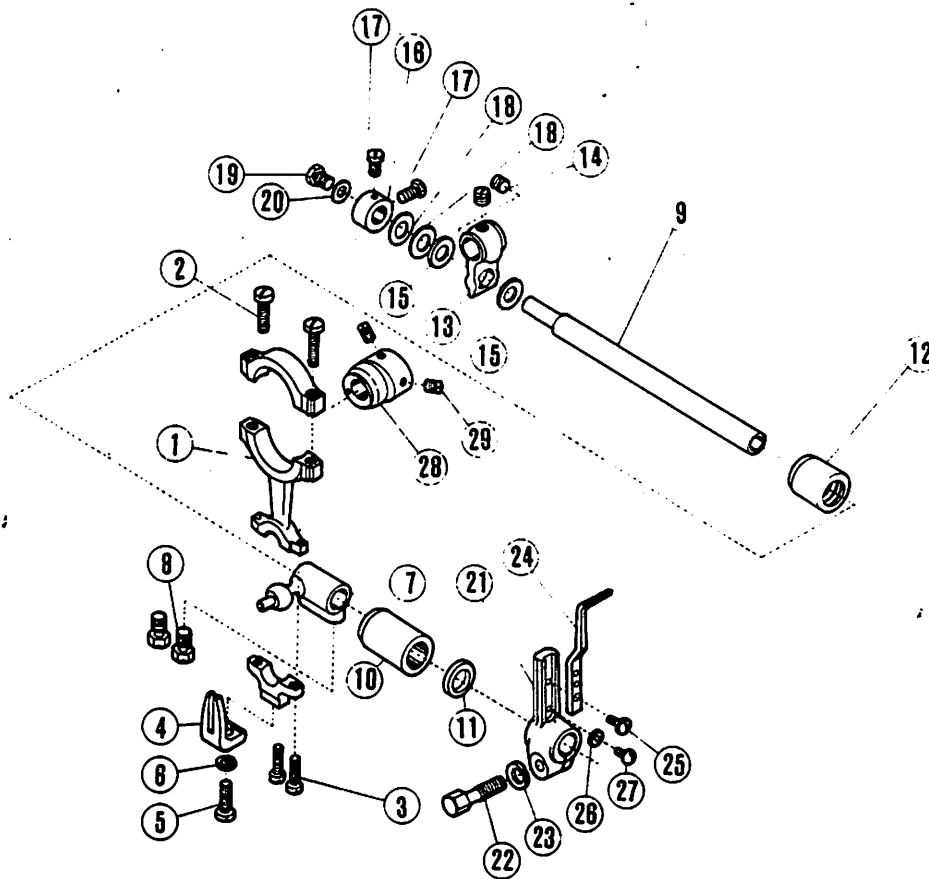
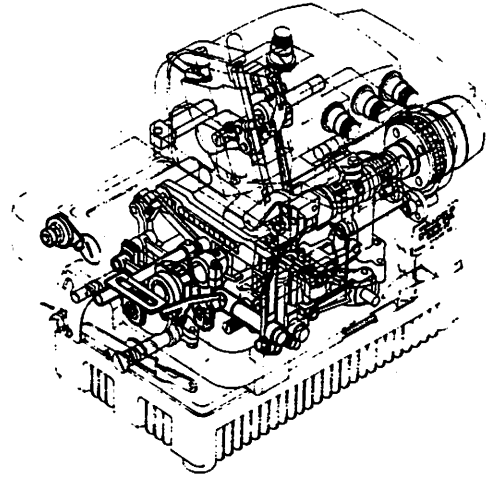

515-516/IV
(1) CHAINSTITCH LOOPER DRIVE MECHANISM

<u>REF. NO.</u>	<u>NEW PRODUCT CODE NO.</u>	<u>OLD NO.</u>	<u>DESCRIPTION</u>
1	323-525-231	204075	Looper drive connection
2	323-600-296	5233	Looper drive connection cap screw (large) (2 used)
3	323-600-020	1170-1	Looper drive connection cap screw (small) (2 used)
4	323-850-200	201074A	Looper drive connection guide
5	323-600-200	1156	Looper drive connection guide screw
6	323-617-200	202286	Looper drive connection guide screw washer
7	323-576-219	204076	Looper drive crank
8	323-600-022	2022-4	Looper drive crank screw (2 used)
9	323-540-225	204079	Looper drive shaft
10	323-540-234	204080	Looper drive shaft bushing (front)
11	323-626-201	204052A	Looper drive shaft bushing (front) oil seal
12	323-676-236	204081	Looper drive shaft bushing (rear)
13	323-730-211	204090	Looper avoiding link
14	323-600-043	2022	Looper avoiding link screw (2 used)
15	323-618-206	204091	Looper avoiding link thrust washer (2 used)
16	323-680-206	204092	Looper avoiding link collar
17	323-600-013	5084	Looper avoiding link collar screw (2 used)
18	323-643-209	204233	Looper avoiding link spring (2 used)
19	323-600-271	2193	Looper avoiding link spring screw
20	323-615-012	201185	Looper avoiding link spring screw washer
21	323-530-226	204093	Looper lever
22	323-600-306	5284	Looper lever clamp screw
23	323-616-200	204293	Looper lever clamp screw washer
24	* 323-810-217	204314A	Looper, for 2 & 3mm needle gauge
	* 323-810-219	204431	Looper, for 5mm needle gauge
25	323-600-301	1189	Looper screw
26	323-716-208	204172	Looper regulator
27	323-600-048	1333	Looper regulator screw
28	323-580-208	204077	Looper drive eccentric, complete with 204078
	323-540-233	204078	Looper drive eccentric pin
29	323-600-043	2022	Looper drive eccentric screw (2 used)

*See Organization Chart

515-516/IV
(2) CHAINSTITCH LOOPER DRIVE
MECHANISM

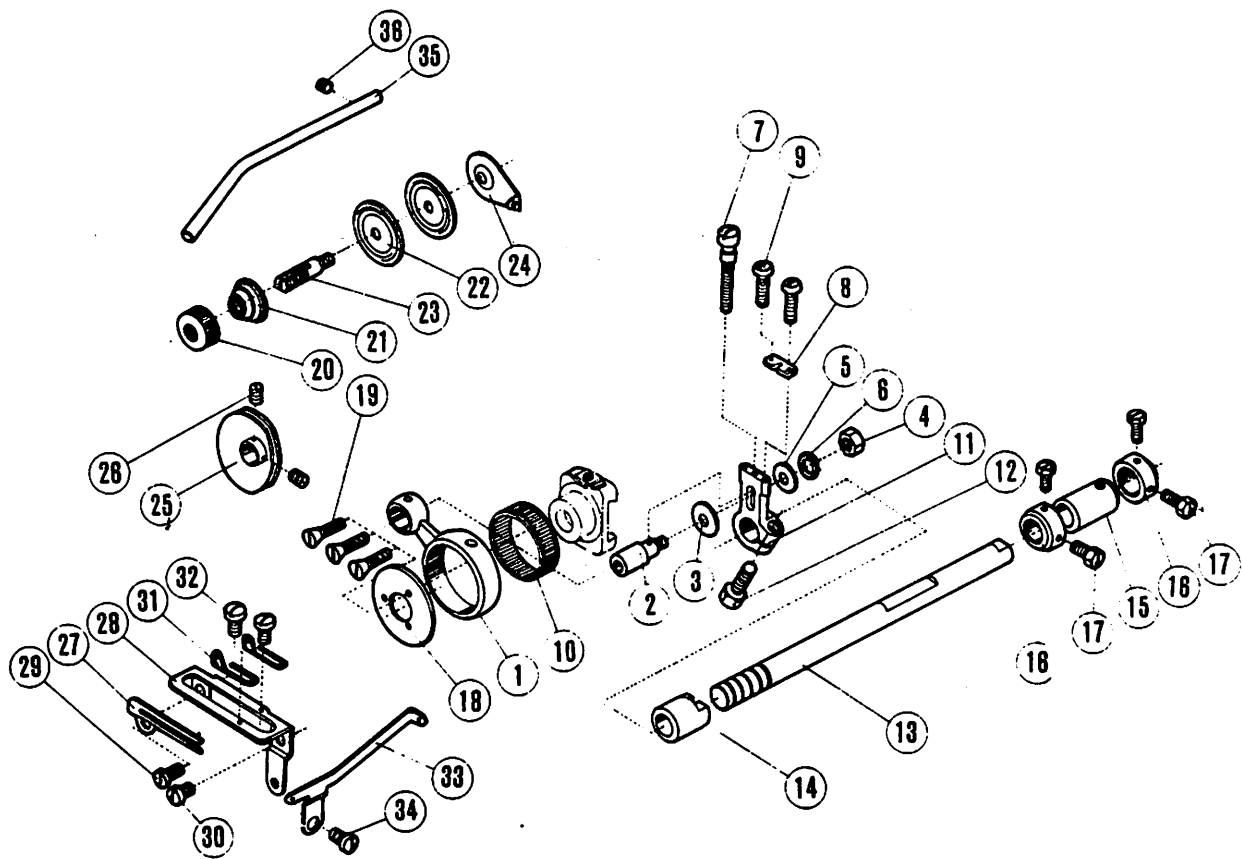
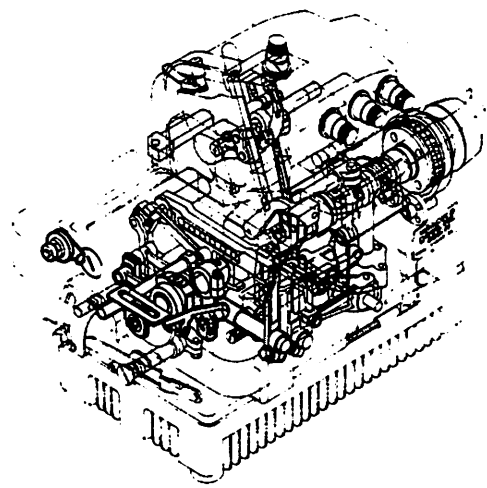

515-516/IV
(2) CHAINSTITCH LOOPER DRIVE MECHANISM

REF. NO.	NEW PRODUCT CODE NO.	OLD NO.	DESCRIPTION
1	323-525-239	204082A	Looper avoiding connection
2	323-620-253	204519	Looper avoiding connection pin
3	323-615-233	204520	Looper avoiding connection pin washer
4	323-630-001	3044	Looper avoiding connection pin nut
5	323-618-211	204115	Looper avoiding connection pin nut washer
6	323-617-200	202286	Looper avoiding connection pin nut spring washer
7	323-600-358	5333	Looper avoiding regulating screw
8	323-625-201	204518	Looper avoiding regulating screw plate
9	323-600-229	2922	Looper avoiding regulating screw plate screw (2 used)
10	323-672-200	204084	Looper avoiding regulating needle bearing
11	323-576-225	204517	Looper avoiding crank
12	323-600-801	5381	Looper avoiding crank clamp screw
13	323-540-024	204874	Looper avoiding shaft
14	323-676-038	204875	Looper avoiding shaft bushing (left)
15	323-676-250	204089	Looper avoiding shaft bushing (right)
16	323-618-003	201056	Looper avoiding shaft thrust collar (2 used)
17	323-600-013	5084	Looper avoiding shaft thrust collar screw (4 used)
18	323-680-205	204087	Looper avoiding eccentric collar
19	323-600-305	5224	Looper avoiding eccentric collar screw (3 used)
20	323-630-015	3056	Looper thread tension nut
21	323-642-201	167077	Looper thread tension spring
22	323-613-001	201482	Looper thread tension disc (2 used)
23	323-604-229	167072	Looper thread tension post
24	323-800-215	202849	Looper thread tension guide
25	323-866-213	204095A	Looper thread takeup
26	323-600-341	5292	Looper thread takeup screw (2 used)
27	323-850-246	204096	Looper thread takeup guide
28	323-740-032	204097A	Looper thread guide bracket
29	323-600-014	4009-1	Looper thread guide bracket screw (long)
30	323-600-039	5113	Looper thread guide bracket screw (short)
31	323-860-215	204324	Looper thread takeup eyelet (2 used)
32	323-600-307	5077	Looper thread takeup eyelet screw (2 used)
33	323-851-219	204098	Looper thread guide
34	323-600-039	5113	Looper thread guide screw
35	323-851-220	204099	Looper thread tube
36	323-600-012	1457	Looper thread tube screw

503-516/IV
(1) MAIN AND DIFFERENTIAL
FEED MECHANISM

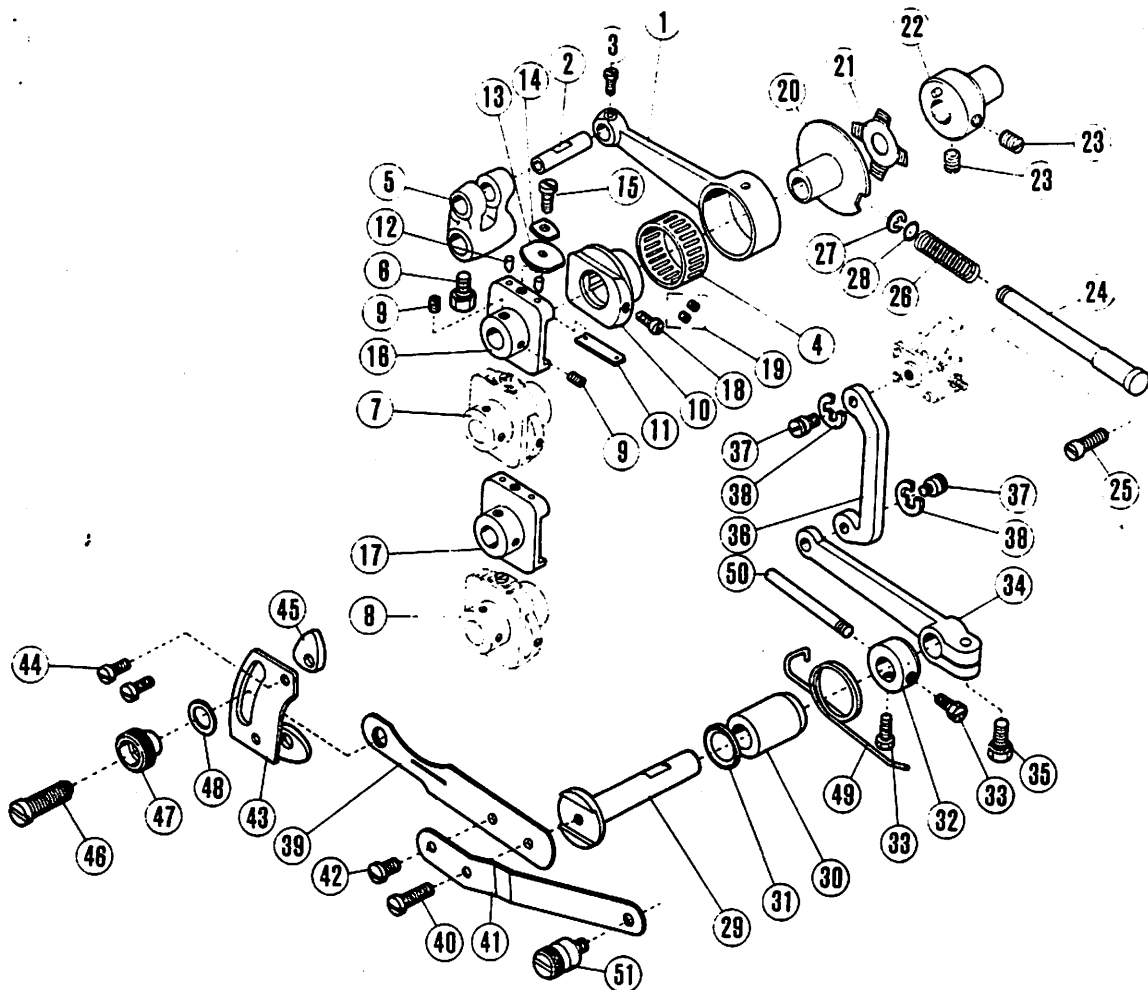
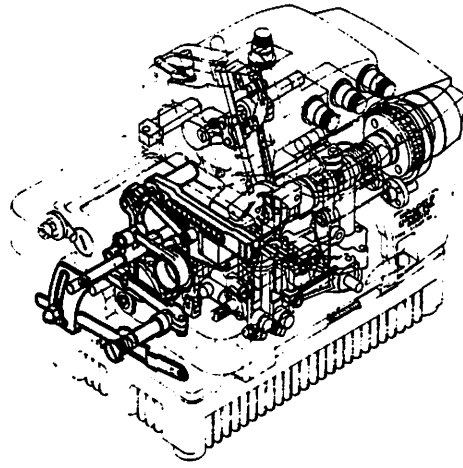

503-516/IV
(1) MAIN AND DIFFERENTIAL FEED MECHANISM

REF. NO.	NEW PRODUCT CODE NO.	OLD NO.	DESCRIPTION	503/IV	
				504/IV 514/IV	515/IV 516/IV
1	323-525-232	204100	Feed drive connection	x	x
2	323-620-237	202711A	Feed drive connection pin	x	x
3	323-600-013	5084	Feed drive connection pin screw	x	x
4	323-672-200	204084	Feed drive connection needle bearing	x	x
5	323-576-220	204085	Feed drive crank	x	x
6	323-600-801	5381	Feed drive crank clamp screw	x	x
7	323-750-206	204352	Feed & looper eccentric, complete with 204101A 204353, 204354x2, 204355, 204356, 1196 & 204086B		x
8	323-900-013	204736	Feed eccentric, complete with 204101A, 204353, 204354x2, 204355, 204356, 1196 & 204735	x	
9	323-600-351	5312	Feed (& looper) eccentric screw (2 used)	x	x
10	323-580-211	204101A	Feed eccentric	x	x
11	323-787-202	204353	Feed eccentric liner	x	x
12	323-620-251	204354	Feed eccentric liner pin (2 used)	x	x
13	323-643-213	204355	Feed eccentric liner spring plate (large)	x	x
14	323-643-214	204356	Feed eccentric liner spring plate (small)	x	x
15	323-600-029	1196	Feed eccentric liner spring plate screw	x	x
16	323-580-210	204086B	Chainstitch looper eccentric		x
17	323-686-010	204735	Feed eccentric retainer	x	
18	323-600-068	1216	Feed eccentric stop screw (for 2:1 diff. feed ratio)	x	x
19	323-600-034	1459	Feed eccentric oil plug (for 3:1 diff. feed ratio)	x	x
20	323-716-215	204102A	Feed eccentric regulator	x	x
21	323-643-212	204357	Feed eccentric latch spring	x	x
22	323-680-006	204637	Feed eccentric regulator collar, complete with 204078	x	
23	323-600-043	2022	Feed eccentric regulator collar screw (2 used)	x	
24	323-540-233	204078	Feed eccentric regulator collar pin	x	
25	323-535-212	204134A	Feed eccentric push rod	x	x
26	323-600-215	2133-1	Feed eccentric push rod screw	x	x
27	323-640-218	204135	Feed eccentric push rod spring	x	x
28	323-634-200	202522	Feed eccentric push rod stop ring	x	x
29	323-632-201	204185	Feed eccentric push rod "o" ring	x	x
30	323-540-017	204752	Diff. feed shaft	x	x
31	323-676-027	204753	Diff. feed shaft bushing	x	x
32	323-626-201	204052A	Diff. feed shaft bushing oil seal	x	x
33	323-680-007	204754	Diff. feed shaft thrust collar	x	x
34	323-600-013	5084	Diff. feed shaft thrust collar screw (2 used)	x	x
35	323-502-213	204139A	Diff. feed shaft arm	x	x
36	323-600-801	5381	Diff. feed shaft arm clamp screw	x	x
37	323-730-214	204140A	Diff. feed link	x	x
38	323-600-347	5316	Diff. feed link screw, complete with 204498 (2 used)	x	x
39	323-634-200	202522	Diff. feed link screw retaining ring (2 used)	x	x
40	323-530-011	204755	Diff. feed regulating lever (rear)	x	x
41	323-600-060	5118	Diff. feed regulating lever (rear) screw	x	x
42	323-530-018	204883	Diff. feed regulating lever (front)	x	x
43	323-600-068	1216	Diff. feed regulating lever (front) screw	x	x
44	323-800-036	204142B	Diff. feed regulating lever guide	x	x
45	323-600-060	5118	Diff. feed regulating lever guide screw (2 used)	x	x
46	323-891-200	204143A	Diff. feed regulating lever lift guide (2 used)	x	x
47	323-600-083	5321A	Diff. feed regulating lever adjusting screw	x	x
48	323-630-017	204870	Diff. feed regulating lever adjusting nut	x	x
49	323-618-209	202868	Diff. feed regulating lever adjusting nut washer	x	x
50	323-640-006	204756	Diff. feed regulating spring	x	x
51	323-600-102	204757	Diff. feed regulating spring latch screw	x	x
52	323-600-107	204869	Knee controller chain hook latch screw	x	x

503-516/IV
(2) MAIN AND DIFFERENTIAL
FEED MECHANISM

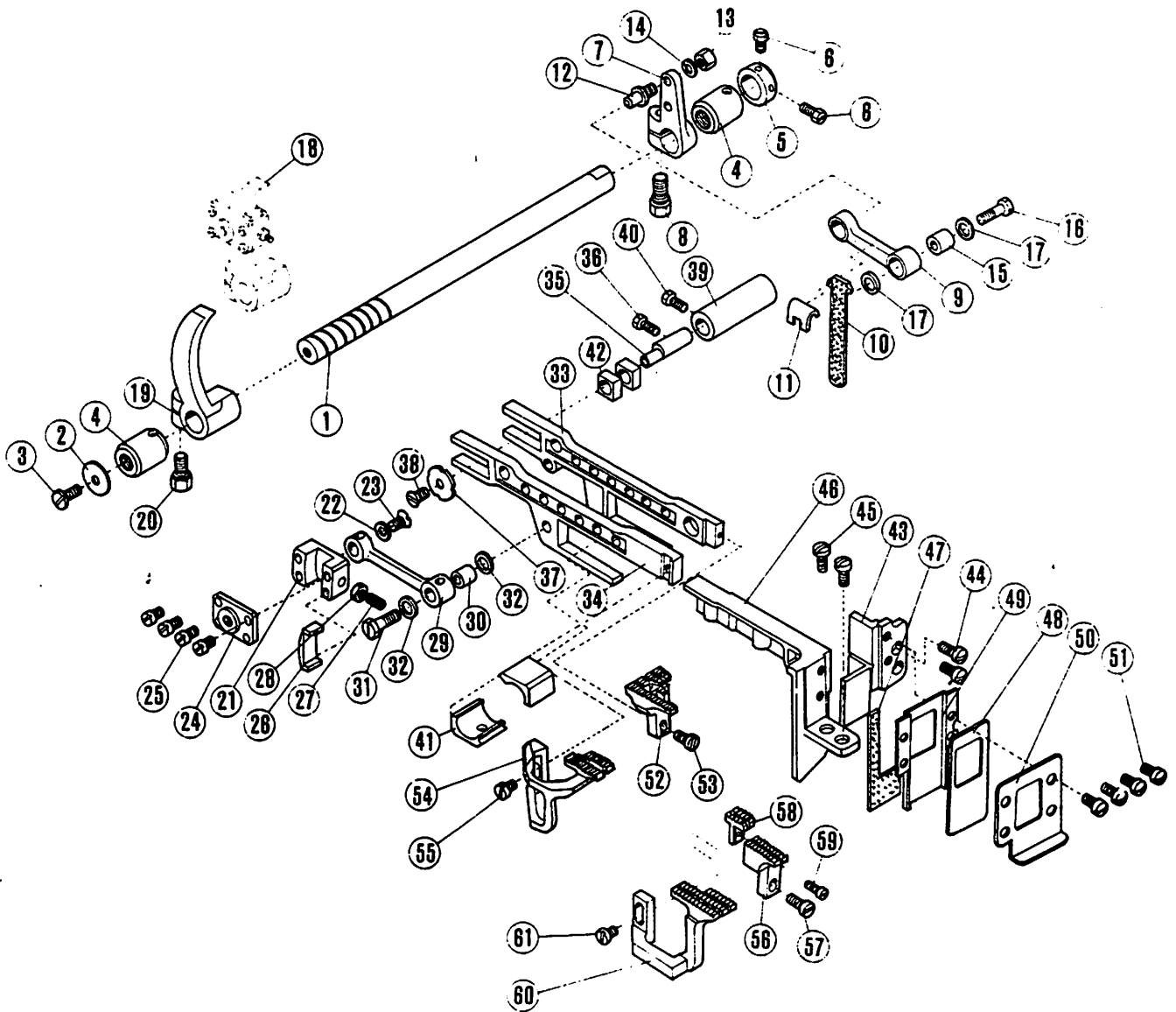
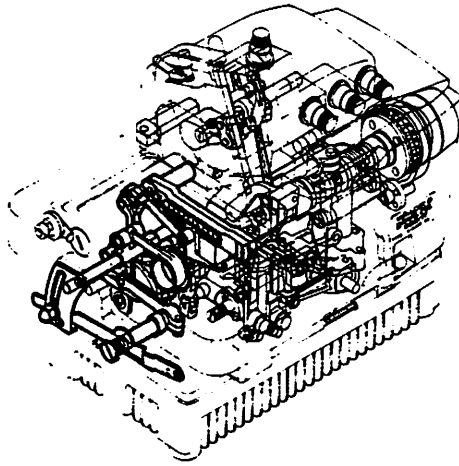

503-516/IV
(2) MAIN AND DIFFERENTIAL FEED MECHANISM

REF. NO.	NEW PRODUCT CODE NO.	OLD NO.	DESCRIPTION	503/IV 504/IV 514/IV	515/IV 516/IV
1	323-540-016	204751	Feed bar shaft	x	x
2	323-618-212	204107	Feed bar shaft thrust washer	x	x
3	323-600-014	4009-1	Feed bar shaft thrust washer screw	x	x
4	323-676-235	204054	Feed bar shaft bushing (2 used)	x	x
5	323-618-003	201056	Feed bar shaft collar	x	x
6	323-600-013	5084	Feed bar shaft collar screw (2 used)	x	x
7	323-576-215	204110A	Main feed regulating crank	x	x
8	323-600-801	5381	Main feed regulating crank clamp screw	x	x
9	323-730-207	204111	Main feed connecting link	x	x
10	323-653-004	204618	Main feed connecting link oil wick	x	x
11	323-686-002	204588	Main feed connecting link oil wick retainer	x	x
12	323-525-233	204112	Main feed connecting link pin	x	x
13	323-630-202	5137	Main feed connecting link pin nut	x	x
14	323-617-200	202286	Main feed connecting link pin nut washer	x	x
15	323-676-251	204114	Main feed connecting link bushing	x	x
16	323-600-309	5231	Main feed connecting link bushing screw	x	x
17	323-618-211	204115	Main feed connecting link bushing screw washer (2 used)	x	x
18	323-716-214	204467	Diff. feed regulator, complete with 204116A, 204117A 204119A, 5029x2, 204121, 1435 & 3044	x	x
19	323-518-202	204116A	Diff. feed regulating segment	x	x
20	323-600-801	5381	Diff. feed regulating segment clamp screw	x	x
21	323-750-203	204117A	Diff. feed regulating block	x	x
22	323-618-213	204118	Diff. feed regulating block thrust washer	x	x
23	323-600-059	3001	Diff. feed regulating block thrust washer screw	x	x
24	323-510-263	204119A	Diff. feed regulating block cover	x	x
25	323-600-256	5029	Diff. feed regulating block cover screw (4 used)	x	x
26	323-770-002	204121	Diff. feed regulating block slide	x	x
27	323-600-069	1435	Diff. feed regulating block slide screw	x	x
28	323-630-001	3044	Diff. feed regulating block slide screw nut	x	x
29	323-525-234	204122	Diff. feed connecting link	x	x
30	323-676-251	204114	Diff. feed connecting link bushing	x	x
31	323-600-309	5231	Diff. feed connecting link bushing screw	x	x
32	323-618-211	204115	Diff. feed connecting link bushing screw washer (2 used)	x	x
33	323-593-003	204123A	Main feed bar	x	x
34	323-593-207	204124	Diff. feed bar	x	x
35	323-620-252	204128A	Feed bar hinge pin	x	x
36	323-600-013	5084	Feed bar hinge pin screw	x	x
37	323-615-231	204439	Feed bar hinge pin washer	x	x
38	323-600-355	5317	Feed bar hinge pin washer screw	x	x
39	323-676-261	204129A	Feed bar guide bushing	x	x
40	323-600-215	2133-1	Feed bar guide bushing screw	x	x
41	323-750-003	204810	Feed bar lift block (split type)	x	x
42	323-750-002	201107	Feed bar guide block (2 used)	x	x
43	323-850-024	204709	Feed bar guide (right)	x	x
44	323-600-353	5205	Feed bar guide (right) screw (2 used)	x	x
45	323-850-026	204710A	Feed bar guide (left), complete with 204814A & 204711	x	x
46	323-600-353	5205	Feed bar guide (left) screw (2 used)	x	x
47	323-850-027	204814A	Feed bar guide (left)	x	x
48	323-663-011	204711	Feed bar guide (left) gasket	x	x
49	323-560-012	204712	Feed bar oil splash guard	x	x
49	323-800-031	204713A	Feed bar oil splash guard insert plate	x	x
50	323-800-028	204714	Feed bar oil splash guard plate	x	x
51	323-600-016	1229	Feed bar oil splash guard plate screw (4 used)	x	x
52	*323-830-xxx		Main feed dog, complete with auxiliary feed dog & 2922	x	x
53	323-600-002	1175-2	Main feed dog screw	x	x
	*323-830-xxx		Auxiliary feed dog		x
	323-600-229	2922	Auxiliary feed dog screw		x
54	*323-830-xxx		Differential feed dog		x
55	323-600-301	1189	Differential feed dog screw		x
56	*323-830-xxx		Main feed dog	x	
57	323-600-002	1175-2	Main feed dog screw	x	
58	*323-830-xxx		Auxiliary feed dog	x	
59	323-600-229	2922	Auxiliary feed dog screw	x	
60	*323-830-xxx		Differential feed dog	x	
61	323-600-301	1189	Differential feed dog screw	x	

*See Organization Chart

503-516/IV
 UPPER AND LOWER KNIFE MECHANISM

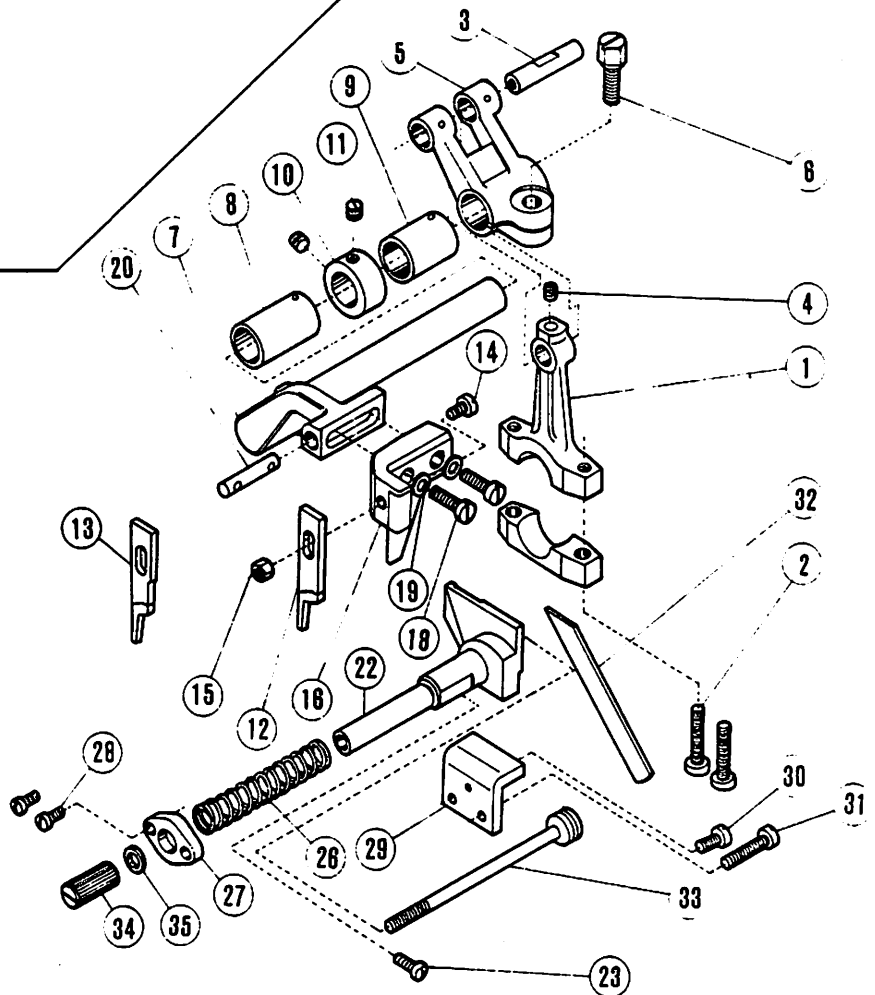
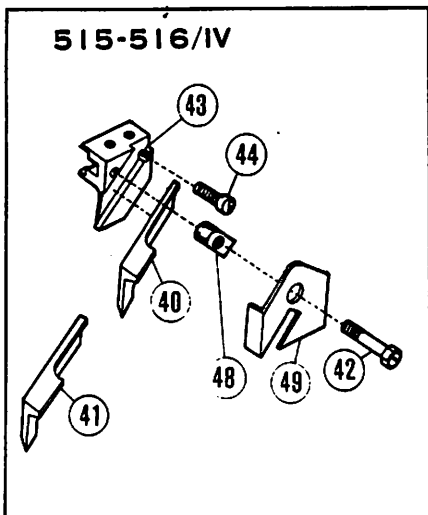
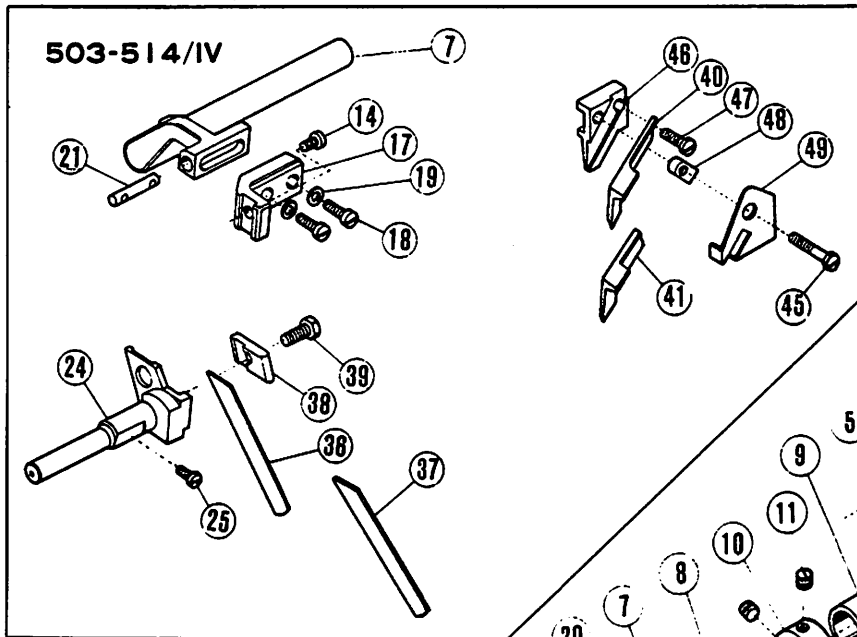
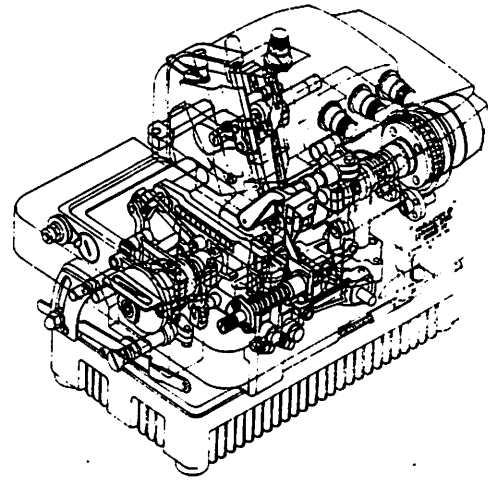

**503-516/IV
UPPER AND LOWER KNIFE MECHANISM**

REF. NO.	NEW PRODUCT		DESCRIPTION	503/IV	
	CODE NO.	OLD NO.		504/IV 514/IV	515/IV 516/IV
1	323-525-235	204145	Upper knife drive connection	x	x
2	323-600-296	5233	Upper knife drive connection cap screw (2 used)	x	x
3	323-620-244	204146	Upper knife drive connection pin	x	x
4	323-600-297	5234	Upper knife drive connection pin screw	x	x
5	323-525-236	204147	Upper knife drive crank	x	x
6	323-600-801	5381	Upper knife drive crank clamp screw	x	x
7	323-685-008	204148B	Upper knife lever	x	x
8	323-676-239	204149	Upper knife lever bushing (left)	x	x
9	323-680-208	204150	Upper knife lever bushing (right)	x	x
10	323-680-207	201635	Upper knife lever thrust collar	x	x
11	323-600-004	5060	Upper knife lever thrust collar screw (2 used)	x	x
12	*323-870-214	201121A	Upper knife (wide) – carbide tipped	x	x
13	*323-870-207	202527	Upper knife (narrow) – carbide tipped	x	x
14	323-600-090	5339	Upper knife screw	x	x
15	323-630-003	3091	Upper knife screw nut	x	x
16	323-683-217	204231A	Upper knife clamp		x
17	323-683-013	204638	Upper knife clamp	x	
18	323-600-002	1175-2	Upper knife clamp screw (2 used)	x	x
19	323-615-013	200821	Upper knife clamp screw washer (2 used)	x	x
20	323-620-245	204154	Upper knife clamp pin		x
21	323-620-016	204796	Upper knife clamp pin	x	
22	323-685-237	204157	Lower knife holder		x
23	323-600-014	4009-1	Lower knife holder screw		x
24	323-685-012	204758	Lower knife holder	x	
25	323-600-011	5002	Lower knife holder screw	x	
26	323-640-219	204158	Lower knife holder spring	x	x
27	323-625-202	204159	Lower knife holder spring seat	x	x
28	323-600-057	5117	Lower knife holder spring seat screw (2 used)	x	x
29	323-850-247	204160A	Lower knife holder guide	x	x
30	323-600-002	1175-2	Lower knife holder guide screw (short)	x	x
31	323-600-010	5010	Lower knife holder guide screw (long)	x	x
32	*323-870-213	204161	Lower knife		x
33	323-600-331	204162	Lower knife clamp stud		x
34	323-630-203	5260	Lower knife clamp stud nut		x
35	323-615-002	200098	Lower knife clamp stud nut washer		x
36	*323-870-210	202295	Lower knife (thick)	x	
37	*323-870-211	201127	Lower knife (thin)	x	
38	323-683-014	204759	Lower knife clamp	x	
39	323-600-271	2193	Lower knife clamp screw	x	
40	323-870-217	204152	Upper knife (angled)	x	x
41	323-870-004	204835	Upper knife (angled) (carbide tipped)	x	x
42	323-600-312	5229	Upper knife screw		x
43	323-750-202	204153	Upper knife clamp		x
44	323-600-226	1170	Upper knife clamp screw		x
45	323-600-108	5371	Upper knife screw	x	
46	323-683-015	204830	Upper knife clamp	x	
47	323-600-054	5142	Upper knife clamp screw	x	
48	323-683-213	204155	Upper knife gib	x	x
49	323-560-225	204156	Upper knife guard	x	x

OPTIONAL ITEMS

*See Organization Chart

503-516/IV
PRESSER FOOT AND LIFT MECHANISM

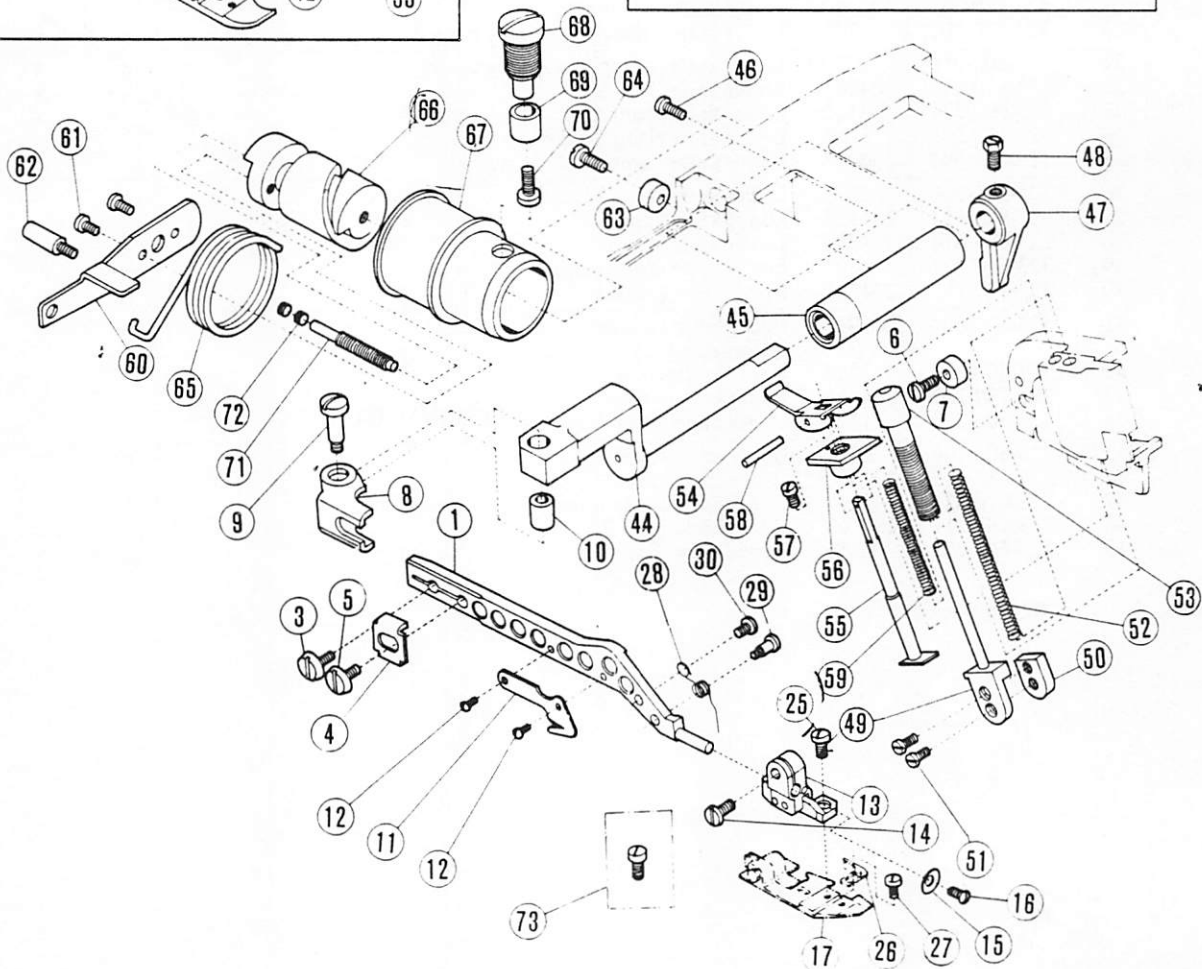
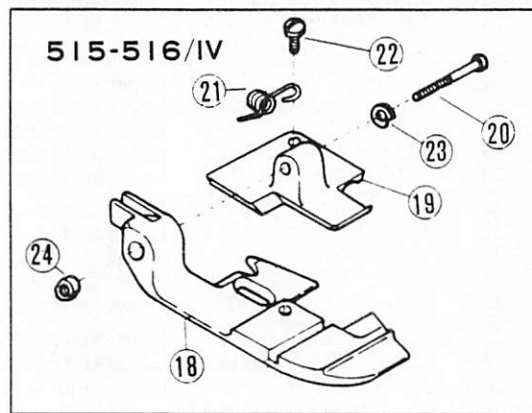
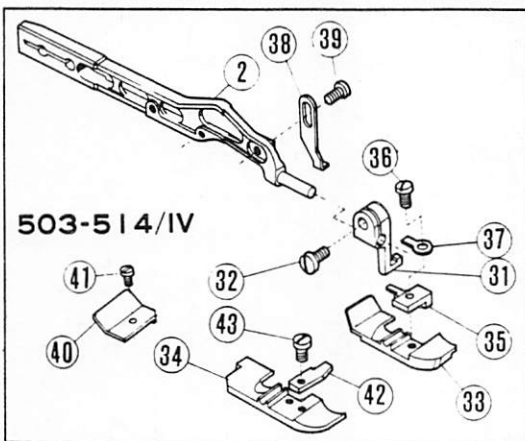
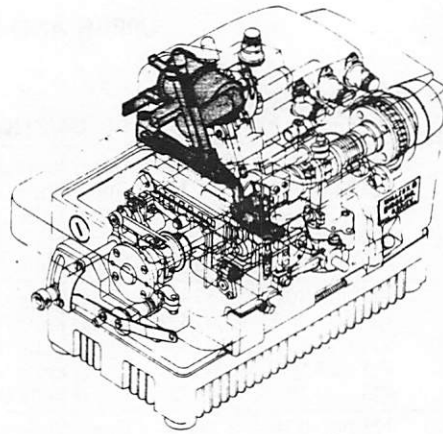

**503-516/IV
PRESSER FOOT AND LIFT MECHANISM**

REF. NO.	NEW PRODUCT CODE NO.	OLD NO.	DESCRIPTION	503/IV 504/IV 514/IV	515/IV 516/IV
1	323-502-209	204163A	Presser arm		
2	323-502-007	204640A	Presser arm	x	x
3	323-600-209	5214	Presser arm screw	x	x
4	323-683-201	202503	Presser arm regulator	x	x
5	323-600-209	5214	Presser arm regulator screw	x	x
6	323-716-209	202683	Presser arm lift regulator	x	x
7	323-600-060	5118	Presser arm lift regulator screw	x	x
8	323-685-240	204237	Presser arm swing-out connection	x	x
9	323-600-047	5164	Presser arm swing-out connection hinge screw	x	x
10	323-680-002	201141	Presser arm swing-out connection hinge screw collar	x	x
11	323-873-001	201308	Chaincutter knife	x	x
12	323-600-048	1333	Chaincutter knife screw (2 used)	x	x
13	323-685-242	204327A	Presser foot holder, complete with 204236B, 204328A & 5323		x
14	323-600-014	4009-1	Presser foot holder bracket screw		x
		204236B	Presser foot holder bracket		x
		204328A	Presser foot holder		x
	323-600-085	5323	Presser foot holder hinge pin-screw		x
15	323-716-208	204172	Presser foot lift regulator		x
16	323-600-307	5077	Presser foot lift regulator screw		x
17	*323-820-xxx		Presser foot, complete		x
18		204169B	Presser foot body (Mfg only)		x
19		204170B	Presser foot auxiliary (Mfg only)		x
20	323-600-104	204496	Presser foot auxiliary hinge pin		x
21	323-633-202	204497	Presser foot auxiliary spring		x
22	323-630-235	5331	Presser foot auxiliary spring screw		x
23	323-640-226	204171B	Presser foot auxiliary hinge pin retaining ring		x
24	323-600-202	5030	Presser foot auxiliary hinge pin nut		x
25	323-600-016	1229	Presser foot screw		x
26	*323-560-xxx		Presser foot fabric guard		x
27	323-600-307	5077	Presser foot fabric guard screw		x
28	323-640-224	204329	Presser foot body spring		x
29	323-600-313	5291	Presser foot body spring screw (large)		x
30	323-600-026	2921	Presser foot body spring screw (small)		x
31	323-685-232	202504A	Presser foot holder bracket	x	
32	323-600-014	4009-1	Presser foot holder bracket screw	x	
33	*323-820-xxx		Presser foot	x	
34	*323-820-xxx		Presser foot	x	
35	*323-863-xxx		Presser foot chaining-off finger	x	
36	323-600-050	5089	Presser foot chaining-off finger screw	x	
37	323-643-001	201156	Presser foot hinge spring	x	
38	323-716-005	204841	Presser foot regulator	x	
39	323-600-026	2921	Presser foot regulator screw	x	
40	*323-560-xxx		Presser foot uncurler	x	
41	323-600-202	5030	Presser foot uncurler screw	x	
42	*323-854-xxx		Presser foot fabric guard	x	
43	323-600-051	1231	Presser foot fabric guard screw	x	
44	323-540-240	204164	Foot lift lever shaft	x	x
45	323-676-240	204165	Foot lift lever shaft bushing	x	x
46	323-600-215	2133-1	Foot lift lever shaft bushing screw	x	x
47	323-530-229	204166	Foot lift intermediate lever	x	x
48	323-600-022	2022-4	Foot lift intermediate lever screw	x	x
49	323-629-200	202641	Presser bar, complete with 202642 & 5053x2	x	x
50	323-850-249	202642	Presser bar guide	x	x
51	323-600-015	5053	Presser bar guide screw (2 used)	x	x
52	323-640-217	201388	Presser bar spring	x	x
53	323-600-317	202643	Pressure regulating thumb screw	x	x
54	323-530-233	202644A	Hand lift lever	x	x
55	323-629-201	202645	Hand lift lever spring plunger	x	x
56	323-676-259	202646A	Hand lift lever spring plunger bushing	x	x
57	323-600-256	5029	Hand lift lever spring plunger bushing screw	x	x
58	323-620-239	202647A	Hand lift lever hinge pin	x	x
59	323-640-228	201395	Hand lift lever spring	x	x
60	323-530-016	204177B	Foot lift lever	x	x
61	323-600-032	1202	Foot lift lever screw (2 used)	x	x
62	323-600-314	5232	Foot lift lever stop screw	x	x
63	323-716-209	202683	Foot lift lever regulator	x	x
64	323-600-060	5118	Foot lift lever regulator screw	x	x
65	323-640-220	204178	Foot lift lever spring	x	x
66	323-710-002	204179A	Foot lift cam	x	x
67	323-676-241	204241	Foot lift cam bushing	x	x
68	323-600-084	204590	Foot lift cam pin screw	x	x
69	323-720-001	204591	Foot lift cam pin roller	x	x
70	323-600-087	5141	Foot lift cam pin roller screw	x	x
71	323-600-315	5236	Foot lift cam regulating screw stud	x	x
72	323-600-316	2913-2	Foot lift cam regulating screw stud stop screw (2)	x	x
73	323-600-026	2921	Cord and piping foot screw		x

*See Organization Chart

503-516/IV
(1) PUMP LUBRICATING MECHANISM

REF. NO.	NEW PRODUCT		DESCRIPTION	503/IV	
	CODE NO.	OLD NO.		504/IV 514/IV	515/IV 516/IV
	323-900-012	204593	Gear pump, complete with parts of Ref. Nos. 1 to 12	x	x
1	323-515-203	204180	Gear pump housing	x	x
2	323-600-326	5145	Gear pump housing oil plug screw	x	x
3	323-800-006	201293A	Gear pump casing plate	x	x
4	323-600-057	5117	Gear pump casing plate screw (4 used)	x	x
5	323-764-001	201294	Pump gear (right)	x	x
6	323-764-002	201295	Pump gear (left)	x	x
7	323-540-237	204183	Pump gear shaft (long)	x	x
8	323-649-001	201009	Pump gear shaft (long) key	x	x
9	323-540-236	204184	Pump gear shaft (short)	x	x
10	323-600-037	1458	Pump gear shaft (short) screw (2 used)	x	x
11	323-570-204	204187	Worm wheel	x	x
12	323-600-004	5060	Worm wheel screw (2 used)	x	x
13	323-570-203	204186	Worm	x	x
14	323-600-043	2022	Worm screw	x	x
15	323-632-201	204185	Gear pump outlet 'O' ring	x	x
16	323-600-072	5094	Gear pump housing screw (2 used)	x	x
17	323-655-002	201338	Oil screen filter	x	x
18	323-663-001	201311	Oil screen filter gasket	x	x
19	323-508-002	201341	Oil screen filter frame	x	x
20	323-600-057	5117	Oil screen filter screw	x	x
21	323-902-020	204188	Oil cooler assembly	x	x
22	323-600-054	5142	Oil cooler tube joint screw (8 used)	x	x
23	323-663-211	204192	Oil cooler tube joint gasket (2 used)	x	x
24	323-683-214	204189	Oil cooler tube clamp	x	x
25	323-600-059	3001	Oil cooler tube clamp screw	x	x

503-516/IV
(2) PUMP LUBRICATING MECHANISM

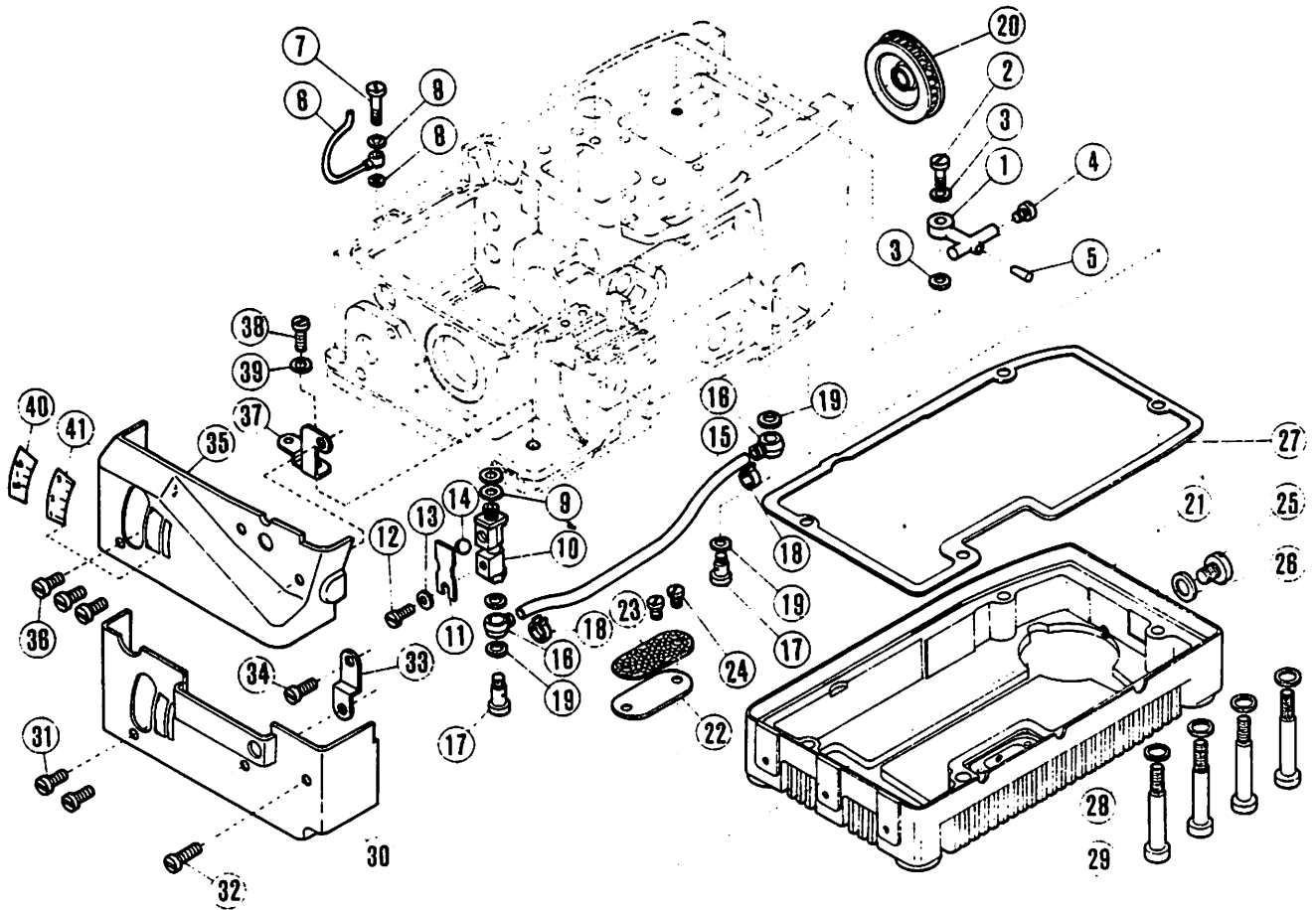
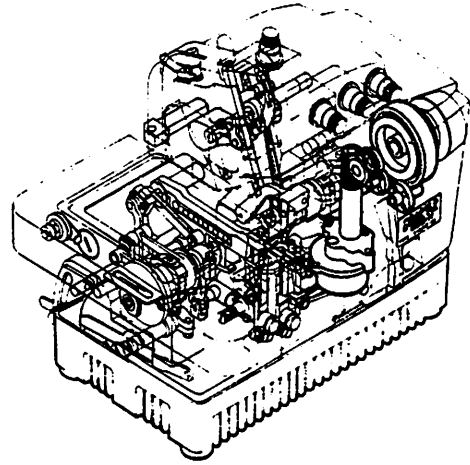

**503-516/IV
(2) PUMP LUBRICATING MECHANISM**

REF. NO.	NEW PRODUCT		DESCRIPTION	503/IV	515/IV
	CODE NO.	OLD NO.		504/IV 514/IV	516/IV
1	323-639-232	204193	Oil distributor	x	x
2	323-604-209	200152	Oil distributor screw	x	x
3	323-615-209	200138	Oil distributor screw washer (2 used)	x	x
4	323-600-062	201323	Oil distributor splash screw	x	x
5	323-627-208	202903	Oil distributor plug	x	x
6	323-639-233	204194	Oil splash pipe	x	x
7	323-600-064	201758	Oil splash pipe screw	x	x
8	323-615-010	201759	Oil splash pipe screw washer (2 used)	x	x
	323-736-002	204845	Oil pressure relief valve, complete with 204846, 204822, 2921, 202875 & 204847	x	x
9	323-615-209	200138	Oil pressure relief valve casing washer (2 used)	x	x
10		204846	Oil pressure relief valve casing	x	x
11	323-641-001	204822	Oil pressure relief valve spring	x	x
12	323-600-026	2921	Oil pressure relief valve spring screw	x	x
13	323-615-216	202875	Oil pressure relief valve spring screw washer	x	x
14	323-610-001	204847	Oil pressure relief valve ball	x	x
15	323-639-018	200698	Oil tube for lubricating 204016 crankshaft bushing (center)	x	x
16	323-636-200	200136	Oil tube joint (2 used)	x	x
17	323-604-209	200152	Oil tube joint stud (2 used)	x	x
18	323-685-003	202199	Oil tube clamp (2 used)	x	x
19	323-615-209	200138	Oil tube joint washer (4 used)	x	x
20	323-568-202	204198	Oil cooling fan	x	x
21	323-713-201	204200A	Oil pan	x	x
22	323-655-205	204202	Oil pan filter	x	x
23	323-800-221	204203	Oil pan filter plate	x	x
24	323-600-068	1216	Oil pan filter plate screw (2 used)	x	x
25	323-600-354	5138B	Oil drain plug screw	x	x
26	323-615-229	202287A	Oil drain plug screw washer	x	x
27	323-663-206	204201	Oil pan gasket	x	x
28	323-605-006	5150B	Oil pan bolt (4 used)	x	x
29	323-615-029	204806	Oil pan bolt washer (4 used)	x	x
30	323-510-032	204865	Machine cover (left) (for cloth plate (wide) 204798) (used with parts of Ref. Nos. 31-34)	x	x
31	323-600-257	5091	Machine cover (left) screw (short) (2 used)	x	x
32	323-600-109	5182	Machine cover (left) screw (long)	x	x
33	323-646-005	204867	Machine cover (left) spacer	x	x
34	323-600-039	5113	Machine cover (left) spacer screw	x	x
35	323-510-031	204857	Machine cover (left) (for cloth plate (narrow) 204740) (used with parts of Ref. Nos. 36-39)	x	
36	323-600-360	5092	Machine cover (left) screw (3 used)	x	
37	323-646-004	204868	Machine cover (left) spacer	x	
38	323-600-239	2308	Machine cover (left) spacer screw	x	
39	323-615-213	202058	Machine cover (left) spacer screw washer	x	
40	323-891-202	204493	2:1 diff. feed ratio indication plate	x	x
41	323-891-201	204494	3:1 diff. feed ratio indication plate	x	x

SHIRRING ATTACHMENT

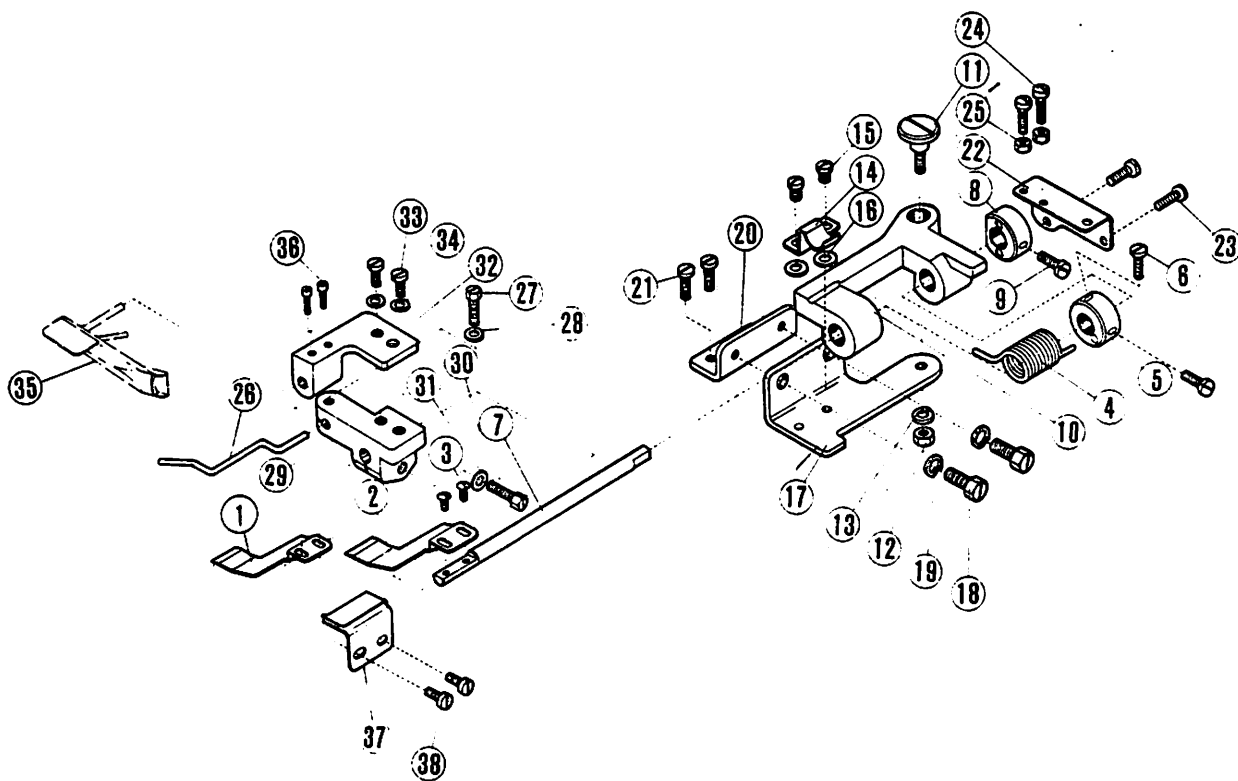

KNEE CONTROLLER

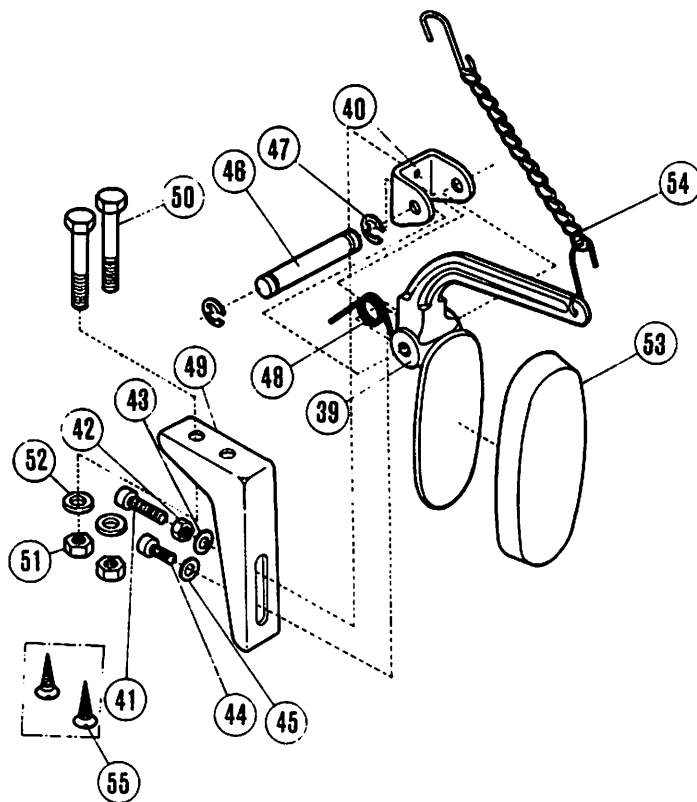

(1) ATTACHMENTS

REF. NO.	NEW PRODUCT CODE NO.	OLD NO.	DESCRIPTION
	*323-900-215	204670	Shirring attachment, complete – 515-516/IV (used with shirring blade 205064 and parts of Ref. Nos. 3 to 31)
	*323-900-014	204882	Shirring attachment, complete – 504-514/IV (used with shirring blade 205137 and parts of Ref. Nos. 3 to 31)
1	323-875-200	205064	Shirring blade – 515-516/IV
2	323-875-001	205137	Shirring blade – 504-514/IV
3	323-600-302	5227	Shirring blade screw (2 used)
4	323-640-225	205065	Shirring attachment spring
5	323-615-227	205066	Shirring attachment spring collar
6	323-600-025	5064	Shirring attachment spring collar screw (2 used)
7	323-540-246	205067	Shirring attachment shaft
8	323-680-210	205068	Shirring attachment shaft collar
9	323-600-237	2213	Shirring attachment shaft collar screw
10	323-750-204	205069	Shirring attachment block
11	323-600-350	5326	Shirring attachment block screw
12	323-630-202	5137	Shirring attachment block screw nut
13	323-617-200	202286	Shirring attachment block screw nut washer
14	323-625-203	205070	Shirring attachment block lock spring
15	323-600-016	1229	Shirring attachment block lock spring screw (2 used)
16	323-618-007	200183	Shirring attachment block lock spring screw washer (2 used)
17	323-800-235	204495	Shirring attachment block plate
18	323-600-271	2193	Shirring attachment block plate screw (2 used)
19	323-617-200	202286	Shirring attachment block plate screw washer (2 used)
20	323-740-229	204451	Shirring attachment block plate extension
21	323-600-057	5117	Shirring attachment block plate extension screw (2 used)
22	323-530-232	205072	Shirring blade swing-out lever
23	323-600-057	5117	Shirring blade swing-out lever screw (2 used)
24	323-600-226	1170	Shirring blade swing-out lever regulating screw (2 used)
25	323-630-003	3091	Shirring blade swing-out lever regulating screw nut (2 used)
26	323-534-001	204592	Shirring blade lifter
27	323-600-088	5276	Shirring blade lifter screw
28	323-615-213	202058	Shirring blade lifter screw washer
29	323-750-205	205104	Shirring blade lifter block
30	323-600-088	5276	Shirring blade lifter block clamp screw
31	323-615-213	202058	Shirring blade lifter block clamp screw washer
32	323-685-243	205103	Cord and piping attachment block
33	323-600-019	1175-3	Cord and piping attachment block screw (2 used)
34	323-615-211	167066	Cord and piping attachment block screw washer (2 used)
35			Cord and piping attachment (binder)
36	323-600-020	1170-1	Cord and piping attachment screw (2 used)
37	323-850-258	205091	Shirring cloth guide
38	323-600-068	1216	Shirring cloth guide screw (2 used)
	323-900-224	192	Knee controller, complete with parts of Ref. Nos. 39 to 55
39	323-530-100	193	Knee controller
40	323-728-004	194	Knee controller hinge
41	323-600-100	5183	Knee controller hinge regulating screw
42	323-630-001	3044	Knee controller hinge regulating screw nut
43	323-615-017	137142	Knee controller hinge regulating screw nut washer
44	323-600-060	5118	Knee controller hinge screw
45	323-615-017	137142	Knee controller hinge screw washer
46	323-620-100	195	Knee controller hinge pin
47	323-634-200	202522	Knee controller hinge pin stop ring (2 used)
48	323-640-100	196	Knee controller hinge spring
49	323-505-100	197	Knee controller hinge bracket
50	323-605-003	5347	Knee controller hinge bracket screw (2 used)
51	323-630-013	5348	Knee controller hinge bracket screw nut (2 used)
52	323-615-021	204585	Knee controller hinge bracket screw nut washer (2 used)
53	323-665-001	198	Knee pad
54	323-732-002	199	Knee pad chain
55	323-600-101	5341	Knee pad hinge bracket wood screw (2 used)

*See Organization Chart

504-516/IV
EDGE GUIDE

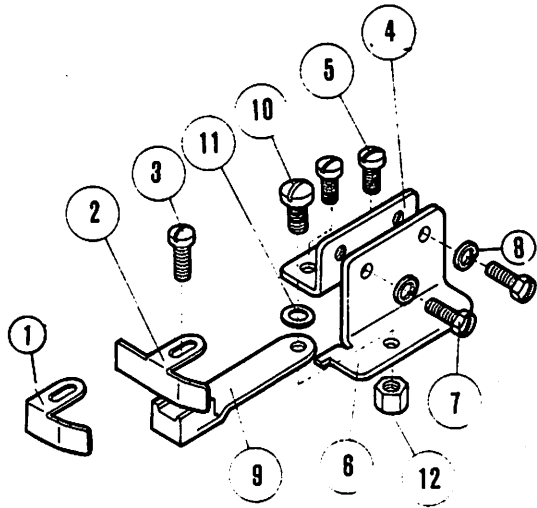

503/IV
WELT GUIDE

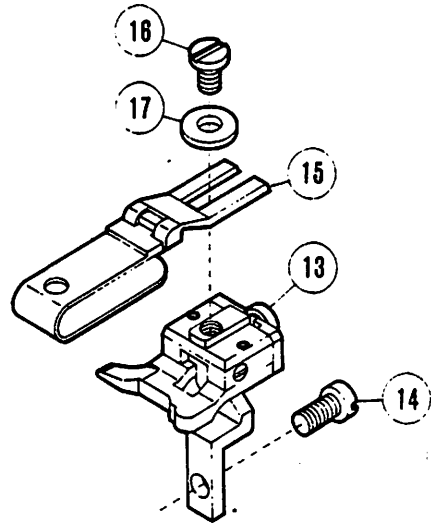

503-514/IV
BACKTACKER

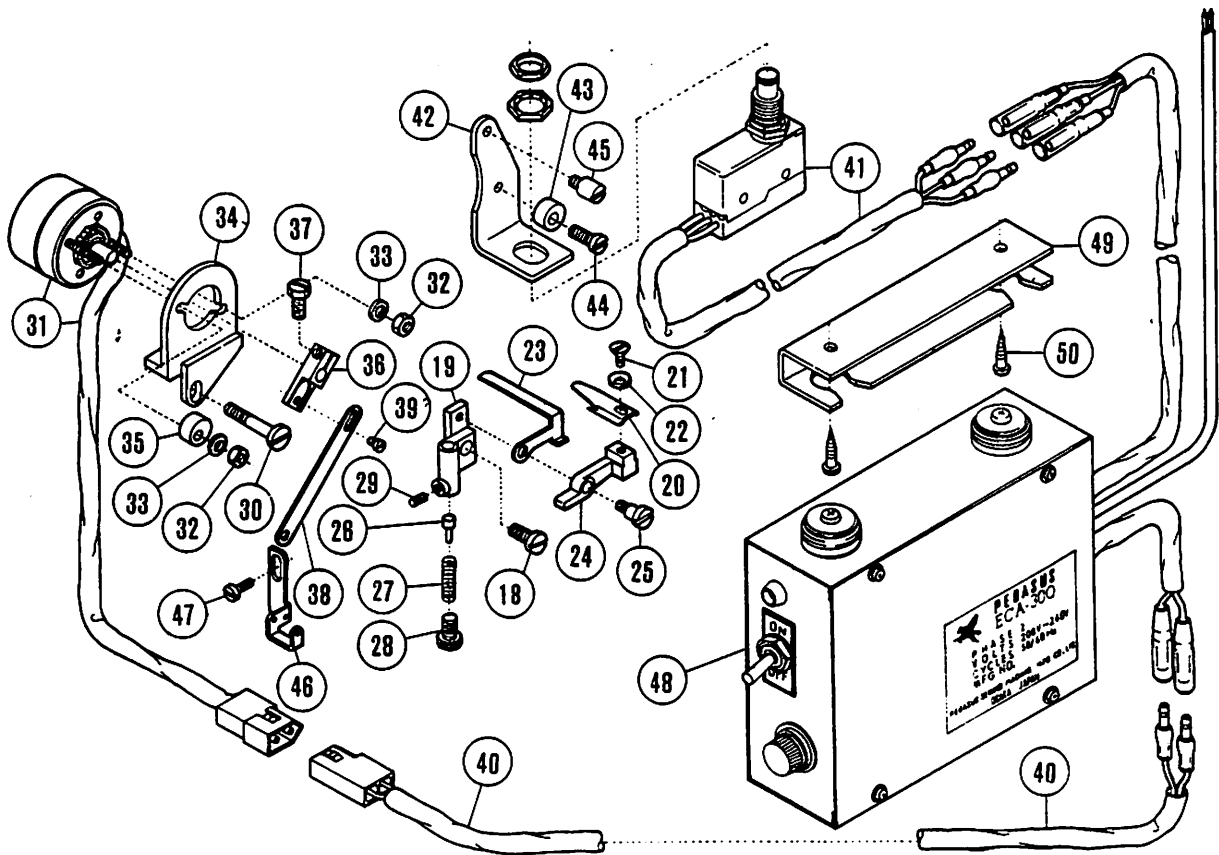

(2) ATTACHMENTS

REF. NO.	NEW PRODUCT CODE NO.	OLD NO.	DESCRIPTION
	323-850-256	204449	Edge guide, complete – 515-516/IV (used with guide #201233A and parts of Ref. Nos. 3 to 12)
	323-850-028	204896	Edge guide, complete – 504-514/IV (used with guide #204667 and parts of Ref. Nos. 3 to 12)
1	323-850-013	201233A	Edge guide – 515-516/IV
2	323-850-022	204667	Edge guide – 504-514/IV
3	323-600-032	1202	Edge guide screw
4	323-740-229	204451	Edge guide holder bracket
5	323-600-057	5117	Edge guide holder bracket screw (2 used)
6	323-740-228	204452	Edge guide holder bracket extension
7	323-600-271	2193	Edge guide holder bracket extension screw (2 used)
8	323-617-200	202286	Edge guide holder bracket extension screw washer (2 used)
9	323-740-012	201485	Edge guide holder
10	323-600-079	5184	Edge guide holder screw
11	323-615-015	201191	Edge guide holder screw washer
12	323-630-010	5074	Edge guide holder screw washer nut
– Welt guide for 504/IV-25			
13	323-505-010	204760	Welt guide base
14	323-600-002	1175-2	Welt guide base screw
15	323-400-001	201211A	Welt guide (1-1/2" hem)
16	323-600-074	2905	Welt guide screw
17	323-615-017	137142	Welt guide screw washer
– Backtacker for 503-514/IV –			
	323-900-017	303135	Backtacker, complete with parts of Ref. Nos. 19 to 29
18	323-600-019	1175-3	Backtacker screw
19	323-505-011	303037	Backtacker base
20	323-873-002	303038	Backtacker blade
21	323-600-251	5022	Backtacker blade screw
22	323-615-030	303039	Backtacker blade screw washer
23	323-850-038	303040	Backtacker blade guide
24	323-530-021	303041	Backtacker blade lever
25	323-600-361	5368	Backtacker blade lever screw
26	323-620-027	303043	Backtacker blade lever push pin
27	323-640-016	303042	Backtacker blade lever push pin spring
28	323-600-362	5369	Backtacker blade lever push pin adjust screw
29	323-600-341	5292	Backtacker blade lever push pin adjust screw lock screw
	323-900-018	303136	Rotary solenoid, complete with parts of Ref. Nos. 31 to 39
30	323-600-363	5370	Rotary solenoid screw
31	323-795-001	811002	Rotary solenoid
32	323-630-022	5367	Rotary solenoid nut (2 used)
33	323-615-012	201185	Rotary solenoid nut washer (2 used)
34	323-740-041	303046	Rotary solenoid bracket
35	323-716-209	202683	Needle thread pull-off takeup lever regulator
36	323-530-022	303049	Needle thread pull-off takeup lever
37	323-600-271	2193	Needle thread pull-off takeup lever clamp screw
38	323-866-014	303048	Needle thread pull-off takeup
39	323-600-026	2921	Needle thread pull-off takeup screw
40	323-900-019	742008	Rotary solenoid cord, complete
41	323-900-020	706001	Micro-switch, complete
42	323-740-042	303050	Micro-switch bracket
43	323-716-209	202683	Foot lift lever regulator – already in the machine
44	323-600-061	5152	Foot lift lever screw
45	323-600-314	5232	Foot lift lever stop screw – already in the machine
46	323-850-039	303047	Needle thread guide
47	323-600-014	4009-1	Needle thread guide screw – already in the machine
48	323-900-021	760009	Electric controller
49	323-740-043	303009	Electric controller bracket
50	323-600-365	5378	Electric controller bracket screw (2 used)

For more information on Backtacker, see its instruction book.

515-516/IV
CHAIN CUTTER MODEL KSU-320

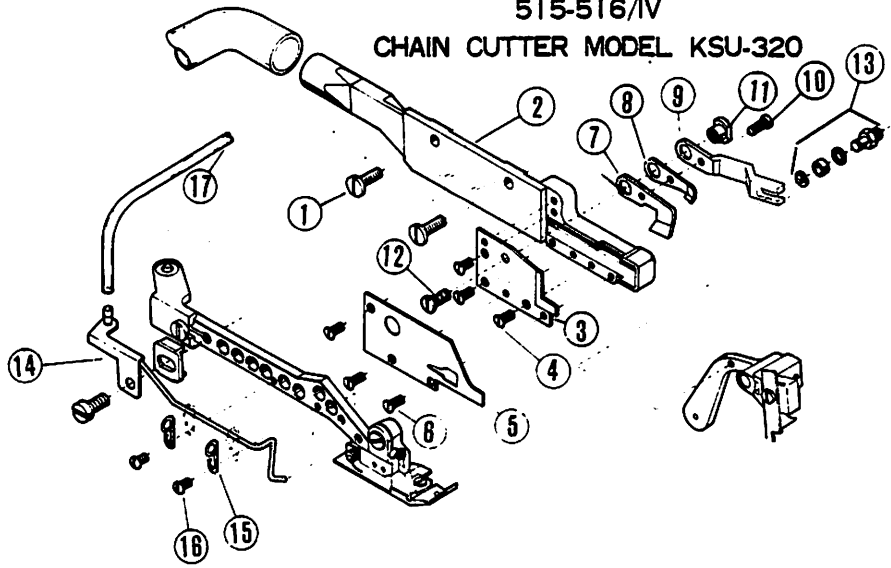

503-514/IV
CHAIN CUTTER MODEL KSU-520

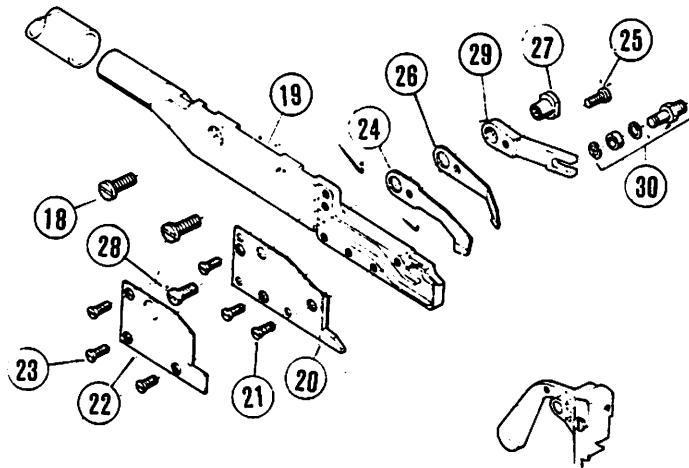

SUCTION DEVICE MODEL VSA-200

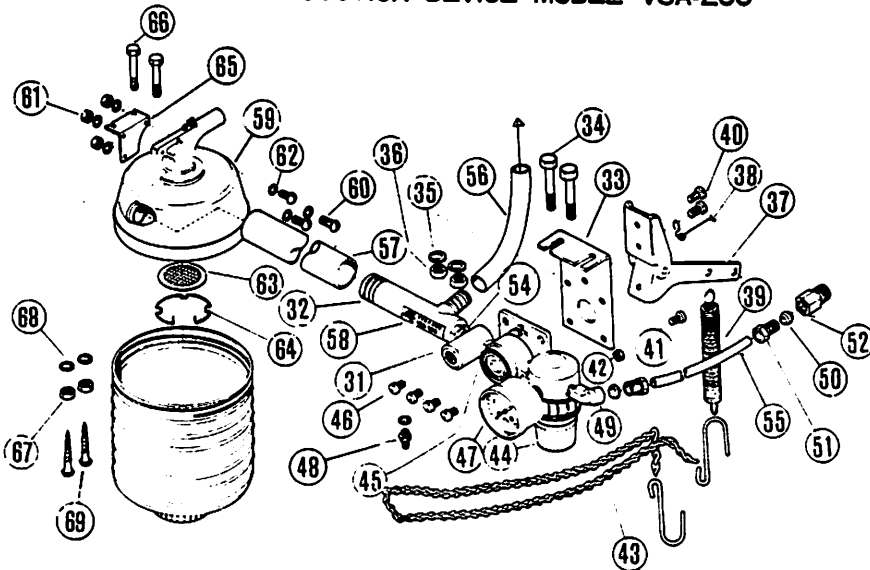

(3) ATTACHMENTS

REF. NO.	NEW PRODUCT CODE NO.	OLD NO	DESCRIPTION
—Chain Cutter Model KSU-320 for 515-516/IV—			
1	323-900-022	303073	Chain cutter frame, complete with parts of Ref. Nos. 2 to 12
2	323-600-014	4009-1	Chain cutter frame screw (2 used)
3	323-508-008	303080	Chain cutter frame
4	323-873-003	303074	Stationary blade
5	323-600-251	5022	Stationary blade screw (3 used)
6	323-560-027	303075	Stationary blade fabric guard
7	323-600-251	5022	Stationary blade fabric guard screw (3 used)
8	323-873-004	303076	Movable blade
9	323-643-007	303077	Movable blade spring
10	323-850-040	303078	Movable blade guide
11	323-600-366	5346	Movable blade screw
12	323-630-023	303079	Movable blade guide screw nut
13	323-600-074	2905	Movable blade guide screw
14	323-620-028	300135	Movable blade guide pin
15	323-639-021	303081A	Air blower
16	323-683-016	303085	Air blower tube clamp (2 used)
17	323-600-048	1333	Air blower tube clamp screw
	323-639-022	303086	Air blower vinyl tube
—Chain Cutter Model KSU-520 for 503-514/IV—			
18	323-900-024	303138	Chain cutter frame, complete with parts of Ref. Nos. 19 to 29
19	323-600-057	5117	Chain cutter frame screw (2 used)
20	323-508-009	303030	Chain cutter frame
21	323-873-005	303031	Stationary blade
22	323-600-251	5022	Stationary blade screw (3 used)
23	323-560-028	303036	Stationary blade fabric guard
24	323-600-251	5022	Stationary blade fabric guard screw (3 used)
25	323-873-006	303032	Movable blade
26	323-600-124	5366	Movable blade screw
27	323-643-008	303033	Movable blade spring
28	323-630-024	303034	Movable blade guide screw nut
29	323-600-014	4009-1	Movable blade guide screw
30	323-850-041	303035	Movable blade guide
	323-620-028	300135	Movable blade guide pin
—Suction Device Model VSA-200—			
31	323-736-003	300027	Needle valve
32	323-651-001	300033	Venturi
33	323-740-044	300037	Air valve bracket
34	323-600-367	5344	Air valve bracket screw (2 used)
35	323-615-021	204585	Air valve bracket screw washer (2 used)
36	323-630-013	5348	Air valve bracket screw nut (2 used)
37	323-716-006	300038	Actuator
38	323-640-017	300042	Actuator hinge spring
39	323-640-018	300043	Actuator spring
40	323-600-014	4009-1	Actuator screw (2 used)
41	323-600-027	1174	Actuator stop screw
42	323-630-003	3091	Actuator stop screw nut
43	323-732-001	126	Actuator chain
44	323-716-007	522001	Air regulator
45	323-736-004	530001	Air valve
46	323-600-039	5113	Air valve screw (4 used)
47	323-891-003	596002	Air pressure gauge
48	323-636-006	601001	Air valve joint
49	323-636-007	601011	Elbow
50	323-635-003	601012	Sleeve (2 used)
51	323-636-011	601013	Nipple joint, for 600005
52	323-636-008	601014	Nipple, for 600005
53	323-636-009	601015	Air valve nipple (right)
54	323-636-010	601016	Air valve nipple (left)
55	323-639-023	600005	Vinyl tube
56	323-639-024	600006	Suction tube
57	323-639-025	600007	Exhaust tube
58	323-692-028	300044	Model plate
59	323-900-023	300105	Waste receptacle complete
60	323-600-364	5354	Waste receptacle screw (3 used)
61	323-630-022	5367	Waste receptacle screw nut (3 used)
62	323-615-012	201185	Waste receptacle screw nut washer (6 used)
63	323-655-009	300107	Air filter
64	323-634-005	300108	Air filter stop ring
65	323-740-045	300109	Waste receptacle bracket
66	323-605-003	5347	Waste receptacle bracket bolt (2 used)
67	323-630-013	5348	Waste receptacle bracket bolt nut (2 used)
68	323-615-021	204585	Waste receptacle bracket bolt nut washer (2 used)
(69)	323-600-101	5341	Waste receptacle bracket wooden screw (2 used)

For more information on Chain Cutter, see its instruction book.

ACCESSORIES

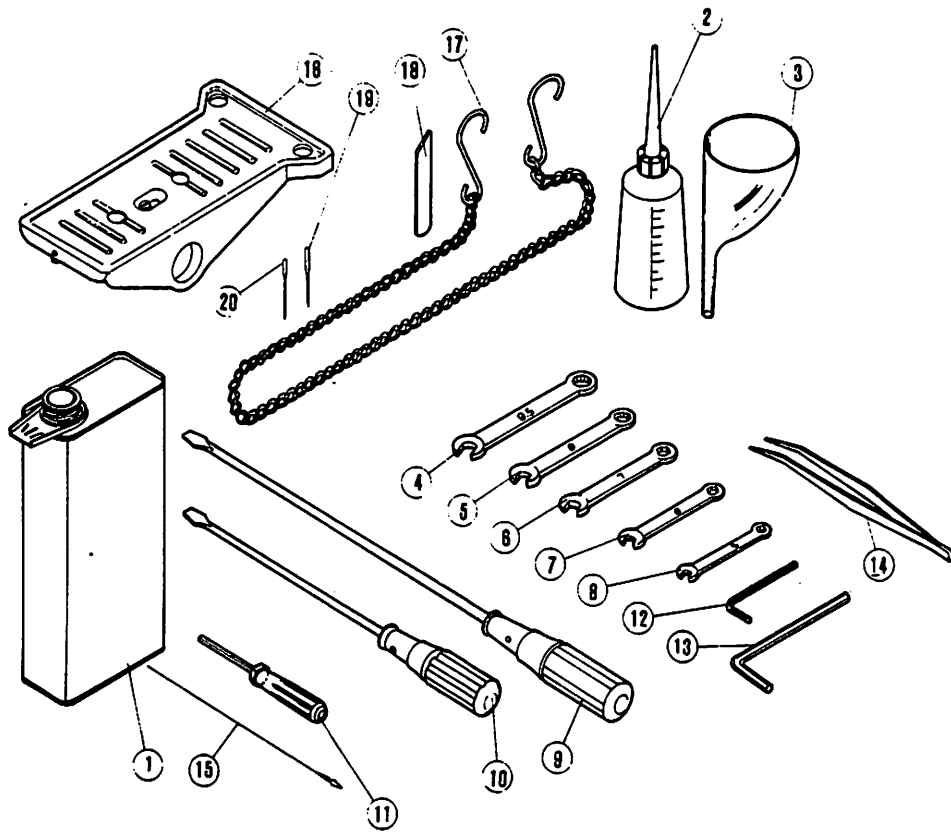

ACCESSORIES FOR SEMI-SUBMERGED INSTALLATION

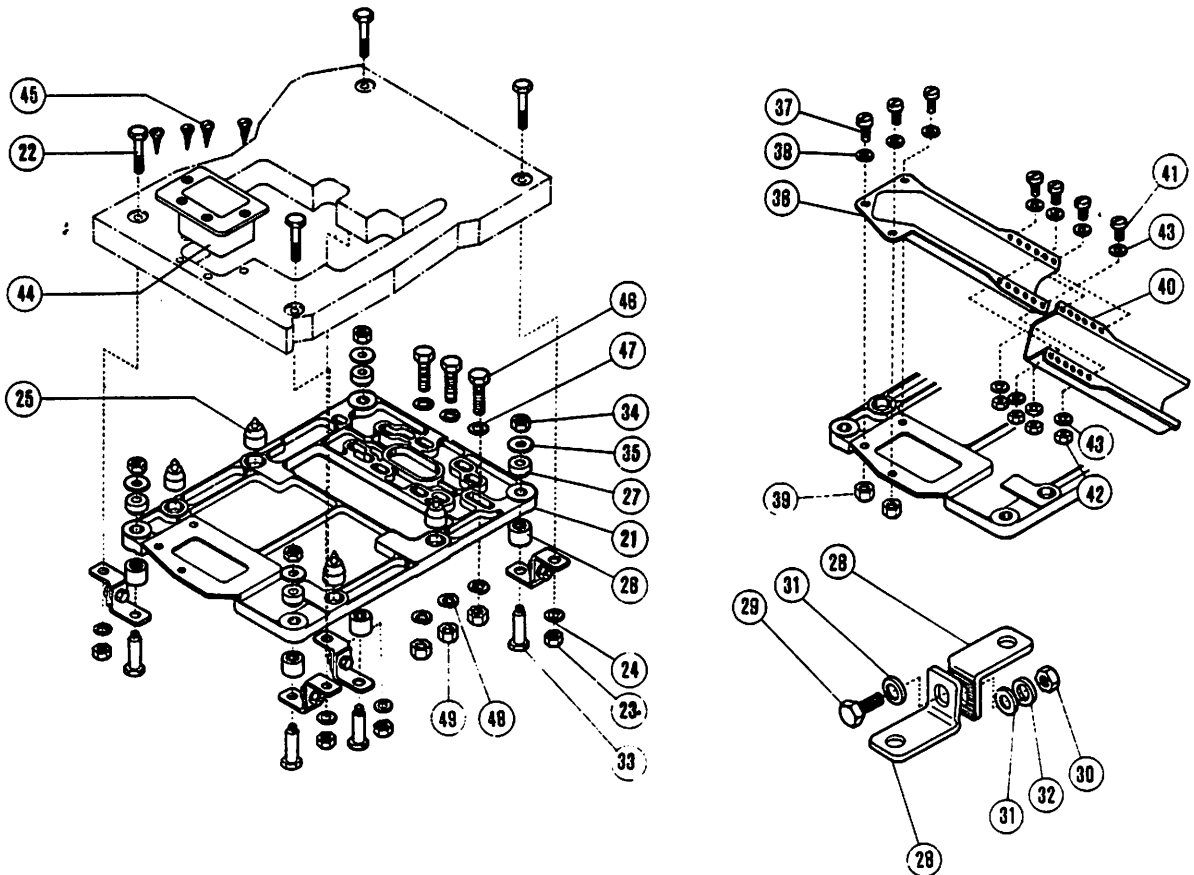

ACCESSORIES

REF. NO.	NEW PRODUCT CODE NO.	OLD NO.	DESCRIPTION
1	323-945-002	133	Oil container
2	323-659-200	132	Oiler
3	323-945-003	135A	Oil funnel
4	323-880-211	130A-9.5	Wrench (9.5mm)
5	323-880-210	130A-8	Wrench (8.0mm)
6	323-880-209	130A-7	Wrench (7.0mm)
7	323-880-208	130A-6	Wrench (6.0mm)
8	323-880-200	130A-5	Wrench (5.0mm)
9	323-885-001	127	Screw driver (large)
10	323-885-002	128	Screw driver (medium)
11	323-885-200	179	Allen wrench
12	323-880-214	182	Allen key (3.17mm)
13	323-880-005	200	Allen key (4.76mm)
14	323-886-001	131	Tweezers
15	323-660-200	153	Threading wire
16	323-533-005	245	Treadle
17	323-732-001	126	Treadle chain
18	323-870-213	204161	Lower knife
19			Needle (10 pieces)
20			Needle (10 pieces) (for 2-needle machine)
– Accessories for semi-submerged installation –			
21	323-945-213	204301C	Machine rest board
22	323-605-202	204303	Machine rest board hanger bolt (4 used)
23	323-630-204	5221	Machine rest board hanger bolt nut (4 used)
24	323-615-203	202700	Machine rest board hanger bolt nut washer (4 used)
25	323-945-202	202691	Machine isolating rubber (4 used)
26	323-945-208	202693A	Machine rest board isolating rubber (lower) (4 used)
27	323-627-204	202765	Machine rest board isolating rubber (upper) (4 used)
28	323-740-223	202768	Machine rest board hanger bracket (8 used)
29	323-600-324	5296	Machine rest board hanger bracket screw (4 used)
30	323-630-228	5297	Machine rest board hanger bracket screw nut (4 used)
31	323-615-219	202769	Machine rest board hanger bracket screw nut washer (8 used)
32	323-616-001	201477	Machine rest board hanger bracket screw nut spring washer (8 used)
33	323-605-203	202766	Machine rest board set bolt (4 used)
34	323-630-229	5298	Machine rest board set bolt nut (4 used)
35	323-615-220	202767	Machine rest board set bolt nut washer (4 used)
36	323-774-001	201348B	Waste chute
37	323-600-217	5017	Waste chute screw (3 used)
38	323-615-002	200098	Waste chute screw washer (3 used)
39	323-630-001	3044	Waste chute screw nut (3 used)
40	323-774-200	201349B	Waste chute extension
41	323-600-060	5118	Waste chute extension screw (4 used)
42	323-630-001	3044	Waste chute extension screw nut (4 used)
43	323-615-002	200098	Waste chute extension screw nut washer (8 used)
44	323-740-013	201346A	Waste chute top
45	323-600-321	175	Waste chute top wood screw (4 used)
46	323-605-204	5302	Motor hanger bolt (3 used)
47	323-615-219	202769	Motor hanger bolt washer (6 used)
48	323-616-001	201477	Motor hanger bolt spring washer (3 used)
49	323-630-228	5297	Motor hanger bolt nut (3 used)

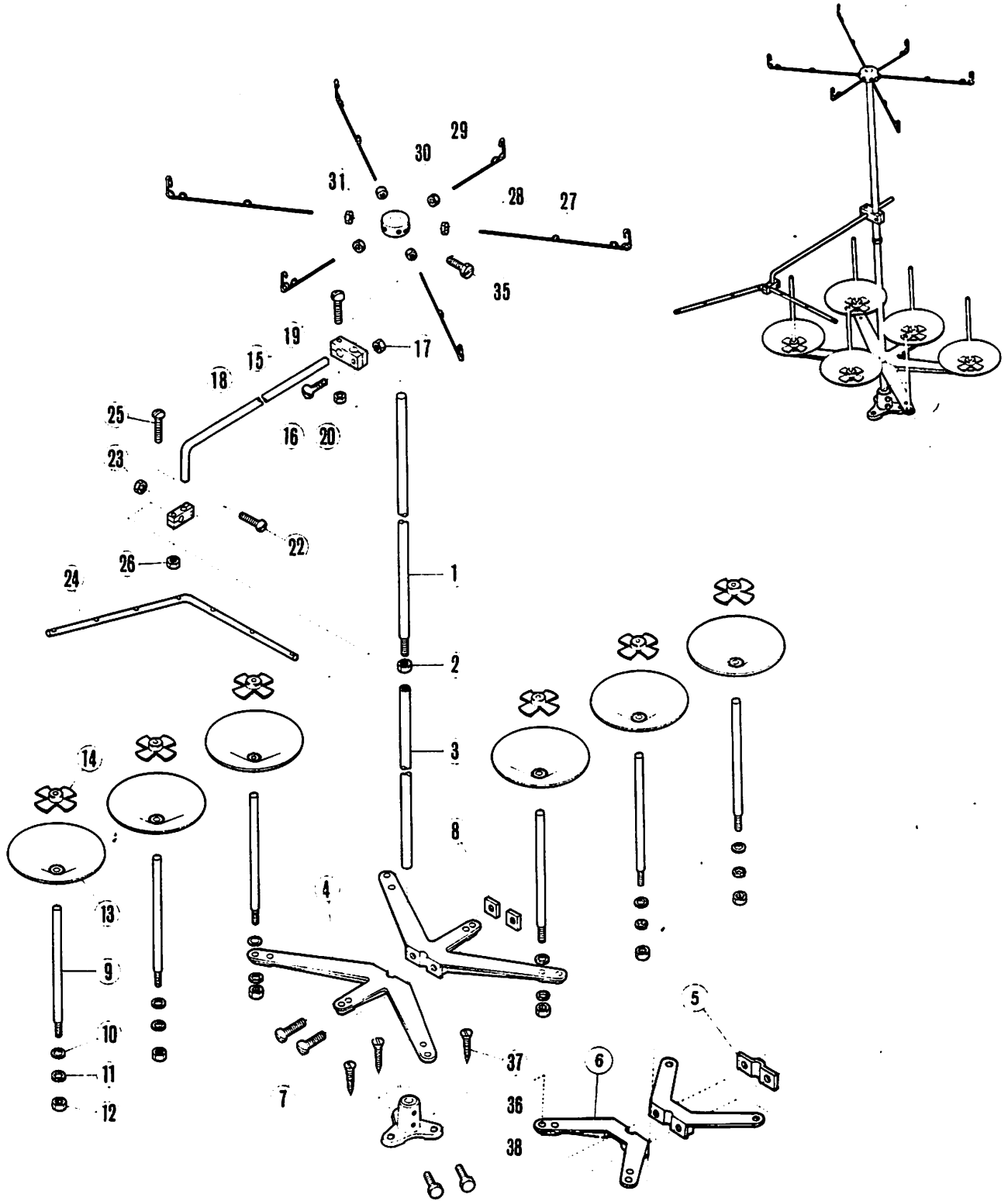

THREAD STAND

REF. NO.	NEW PRODUCT CODE NO.	OLD NO.	DESCRIPTION	NOS. REQUIRED FOR SPOOLS OF			
				3	4	5	6
	323-940-205	208	Thread stand, complete – 3 spools	1	–	–	–
	323-940-206	209	Thread stand, complete – 4 spools	–	1	–	–
	323-940-207	214	Thread stand, complete – 5 spools	–	–	1	–
	323-940-208	210	Thread stand, complete – 6 spools	–	–	–	1
1	323-535-001	216	Thread stand upper rod	1	1	1	1
2	323-600-118	217	Thread stand upper rod screw	1	1	1	1
3	323-535-002	218	Thread stand lower rod	1	1	1	1
4	323-740-035	219	Spool pin bracket	1	–	1	2
5	323-800-041	243	Spool pin bracket clamp plate	1	–	–	–
6	323-740-036	220	Spool pin bracket	–	2	1	–
7	323-600-119	221	Spool pin bracket clamp screw	2	2	2	2
8	323-630-018	222	Spool pin bracket clamp screw nut	2	2	2	2
9	323-620-024	223	Spool pin	3	4	5	6
10	323-615-028	224	Spool pin washer	3	4	5	6
11	323-617-001	225	Spool pin nut spring washer	3	4	5	6
12	323-630-019	226	Spool pin nut	3	4	5	6
13	323-685-013	227	Spool tray	3	4	5	6
14	323-850-031	228	Spool retaining fin	3	4	5	6
15	323-740-034	229	Thread guide bar rod bracket	1	1	1	1
16	323-600-120	230	Thread guide bar rod bracket clamp screw	1	1	1	1
17	323-630-020	231	Thread guide bar rod bracket clamp screw nut	1	1	1	1
18	323-535-003	232	Thread guide bar rod	1	1	1	1
19	323-600-120	230	Thread guide bar rod screw	1	1	1	1
20	323-630-020	231	Thread guide bar rod screw nut	1	1	1	1
21	323-750-006	233	Thread guide rod retaining block	1	1	1	1
22	323-600-120	230	Thread guide rod retaining block clamp screw	1	1	1	1
23	323-630-020	231	Thread guide rod retaining block clamp screw nut	1	1	1	1
24	323-590-003	234	Thread guide bar	1	1	1	1
25	323-600-120	230	Thread guide bar clamp screw	1	1	1	1
26	323-630-020	231	Thread guide bar clamp screw nut	1	1	1	1
27	323-851-021	235	Thread guide wire (long)	2	–	2	4
28	323-630-021	236	Thread guide wire (long) lock nut	2	–	2	4
29	323-851-020	237	Thread guide wire (short)	1	4	3	2
30	323-630-021	236	Thread guide wire (short) lock nut	1	4	3	2
31	323-685-016	260	Thread guide wire holder – 3 spools	1	–	–	–
32	323-685-017	261	Thread guide wire holder – 4 spools	–	1	–	–
33	323-685-018	262	Thread guide wire holder – 5 spools	–	–	1	–
34	323-685-014	238	Thread guide wire holder – 6 spools	–	–	–	1
35	323-600-121	239	Thread guide wire holder screw	1	1	1	1
36	323-505-009	240	Thread stand base	1	1	1	1
37	323-600-122	241	Thread stand base wood screw	3	3	3	3
38	323-600-123	242	Thread stand base rod screw	2	2	2	2

ORGANIZATION CHARTS

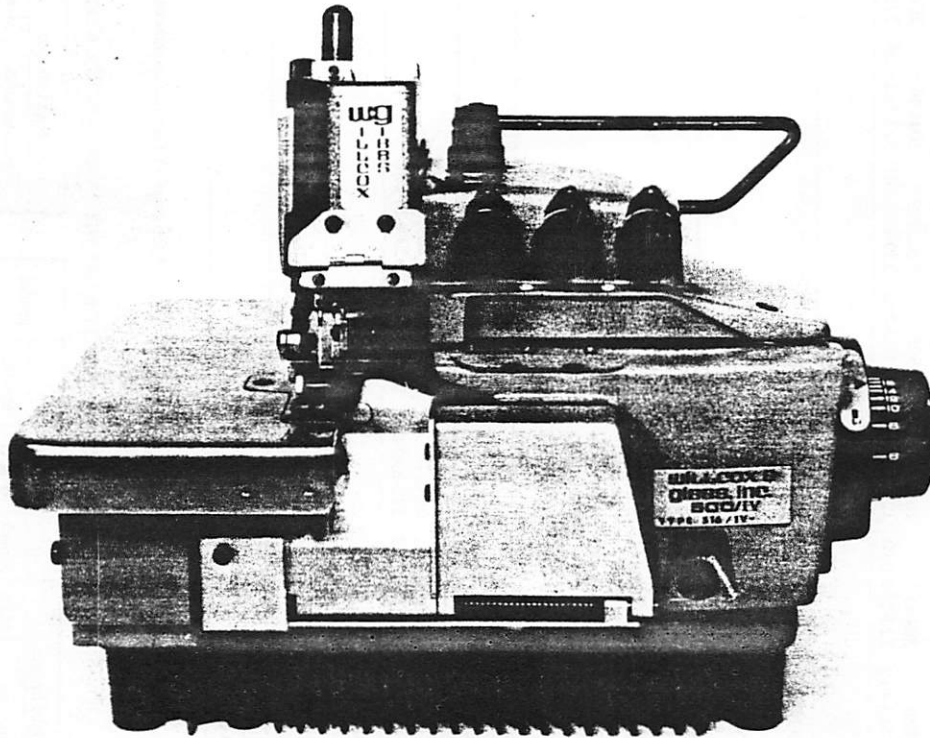

COMMON PARTS: 204072 (323-810-216) – Left looper
201121A (323-870-214) – Upper knife

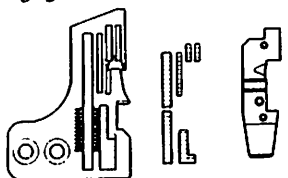
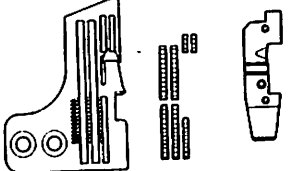
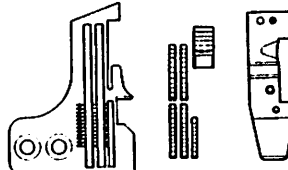
Machine model (Operation)	Gauge (mm) (inch)	Needle plate	Main feed	Differential feed	Auxiliary feed	Presser foot complete	Needle guard (front)	(rear)	Needle bar	Right looper	Lower knife	Others
503/IV-44 Serging trousers 	3mm 1/8"	205320 323-801-062	204692 323-830-030	204907 323-830-060	204908 323-830-055	*202993 323-820-281	204634 323-561-009	204635 323-561-010	204623 323-591-003	204704 323-810-011	202295 323-870-210	
	4mm 5/32"	205321 323-801-063	"	"	"	"	"	"	"	"	"	Needle (factory setting) DCx1 #14 423223631
	5mm 3/16"	205322 323-801-064	"	"	"	"	"	"	"	"	"	Edge guide
	6mm 1/4"	205323 323-801-065	"	"	"	"	"	"	"	"	"	
503/IV-48 Serging trousers 	3mm 1/8"	205324 323-801-066	204909 323-830-053	204690 323-830-057	"	"	"	"	"	"	201127 323-870-211	
	4mm 5/32"	205325 323-801-067	"	"	"	"	"	"	"	"	"	Needle (factory setting) DCx1 #14 423223631
	5mm 3/16"	205326 323-801-068	"	"	"	"	"	"	"	"	202295 323-870-210	Edge guide
	6mm 1/4"	205327 323-801-069	"	"	"	"	"	"	"	"	"	
504/IV-7 Plain seaming for underwear 	3mm 1/8"	202542E 323-801-026	204675 323-830-029	204676 323-830-033	204674 323-830-054	*204956 323-820-026	"	"	"	204062 323-810-218	201127 323-870-211	
	4mm 5/32"	202546E 323-801-027	"	"	"	"	"	"	"	"	"	Needle (factory setting) DCx1 #11 423222831
	5mm 3/16"	202596E 323-801-028	"	"	"	"	"	"	"	"	202295 323-870-210	
	6mm 1/4"	202597E 323-801-029	"	"	"	"	"	"	"	"	"	

503/IV-44

503/IV-48

504/IV-7

*See page 77 for its components.

RIGHT LOOPERS FOR USE WITH VARIOUS SIZE NEEDLES

Right looper		for needle size			Model
Part number	Mark	Singer	W & G	Metric	
204278 323-810-215	1	9-12	027-032	65-80	503/IV
204704 323-810-011	3	13-16	034-040	85-100	
204705 323-810-012	5	17-21	042-051	100-140	

Right looper		for needle size			Model
Part number	Mark	Singer	W & G	Metric	
204062 323-810-218	2	9-12	027-032	65-80	504/IV
204702 323-810-009	4	13-16	034-040	85-100	
204703 323-810-010	6	17-21	042-051	100-140	
204563 323-810-008	7	9-14	027-036	65-90	514/IV

COMMON PARTS: 204072 (323-810-216) – Left looper
201121A (323-870-214) – Upper knife

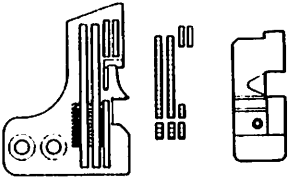
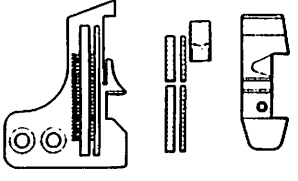
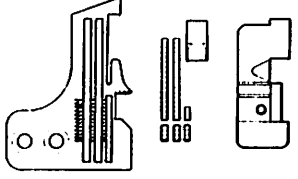
Machine model (Operation)	Gauge (mm) (inch)	Needle plate	Main feed	Differential feed	Auxiliary feed	Presser foot complete	Needle guard (front)	Needle guard (rear)	Needle bar	Right looper	Lower knife	Others
504/IV-17 Intermittent shirring 	3mm 1/8"	205239 323-801-360	204723 323-830-032	204724 323-830-036	204677 323-830-037	*204951 323-820-017	204634 323-561-009	204635 323-561-010	204623 323-591-003	204702 323-810-009	201127 323-870-211	
	4mm 5/32"	205240 323-801-361	"	"	"	"	"	"	"	"	"	Needle (factory setting) DCx27 #14
	5mm 3/16"	205241 323-801-362	"	"	"	*204952 323-820-018	"	"	"	"	202295 323-870-210	423243631 Shirring attachment
	6mm 1/4"	205242 323-801-363	"	"	"	"	"	"	"	"	"	
504/IV-19 Seaming light knit goods 	2mm 5/64"	202616 323-801-038	204729 323-830-052	204730 323-830-059	204674 323-830-054	*204953 323-820-023	"	"	"	204062 323-810-218	"	
	3mm 1/8"	202617 323-801-039	"	"	"	"	"	"	"	"	"	Needle (factory setting) DCx1 #9
	4mm 5/32"	202618 323-801-222	"	"	"	"	"	"	"	"	"	423222631
	5mm 3/16"	204913 323-801-045	"	"	"	"	"	"	"	"	"	
504/IV-21 Intermittent shirring 	3mm 1/8"	202542E 323-801-026	204723 323-830-032	204724 323-830-036	"	*204951 323-820-017	"	"	"	"	201127 323-870-211	
	4mm 5/32"	202546E 323-801-027	"	"	"	"	"	"	"	"	"	Needle (factory setting) DCx1 #11
	5mm 3/16"	202596E 323-801-028	"	"	"	*204952 323-820-018	"	"	"	"	202295 323-870-210	423222831 Shirring attachment
	6mm 1/4"	202597E 323-801-029	"	"	"	"	"	"	"	"	"	

504/IV-17

504/IV-19

504/IV-21

*See page 77 for its components.

RIGHT LOOPERS FOR USE WITH VARIOUS SIZE NEEDLES

Right looper		for needle size				Model
Part number	Mark	Singer	W & G	Metric		
204278	323-810-215	1	9-12	027-032	65-80	503/IV
204704	323-810-011	3	13-16	034-040	85-100	
204705	323-810-012	5	17-21	042-051	100-140	

Right looper		for needle size				Model
Part number	Mark	Singer	W & G	Metric		
204062	323-810-218	2	9-12	027-032	65-80	504/IV
204702	323-810-009	4	13-16	034-040	85-100	
204703	323-810-010	6	17-21	042-051	100-140	
204663	323-810-008	7	9-14	027-036	65-90	514/IV

COMMON PARTS: 204072 (323-810-216) – Left looper
201121A (323-870-214) – Upper knife

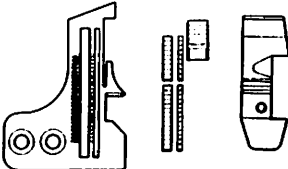
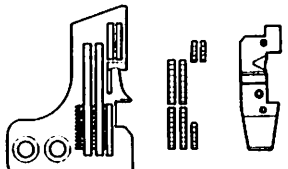
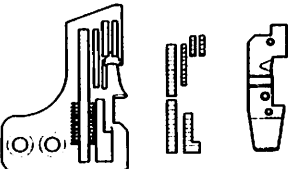
Machine model (Operation)	Gauge (mm) (inch)	Needle plate	Main feed	Differential feed	Auxiliary feed	Presser foot complete	Needle guard (front)	Needle guard (rear)	Needle bar	Right looper	Lower knife	Others
504/IV-25 Hemming light knits 	2mm	202616	204729	204730	204674	*205226	204634	204635	204623	204062	202295	
	5/64"	323-801-038	323-830-052	323-830-059	323-830-054	323-820-220	323-561-009	323-561-010	323-591-003	323-810-218	323-870-210	
	3mm	202617	"	"	"	"	"	"	"	"	"	Needle (factory setting)
	1/8"	323-801-039	"	"	"	"	"	"	"	"	"	DCx1 #9 423222631 Welt guide
504/IV-43 Seaming light knits 	3mm	205235	204721	204722	204677	*202992	"	"	"	204702	201127	
	1/8"	323-801-340	323-830-031	323-830-035	323-830-037	323-820-280	"	"	"	323-810-009	323-870-211	
	4mm	205236	"	"	"	"	"	"	"	"	"	Needle (factory setting)
	5/32"	323-801-341	"	"	"	"	"	"	"	"	"	DCx27 #14 423243631
504/IV-45 Seaming medium-heavy knits 	3mm	205231	204692	204693	"	*202993	"	"	"	"	201127	
	1/8"	323-801-344	323-830-030	323-830-034	"	323-820-281	"	"	"	"	323-870-211	
	4mm	205232	"	"	"	"	"	"	"	"	"	Needle (factory setting)
	5/32"	323-801-345	"	"	"	"	"	"	"	"	"	DCx27 #14 423243631
	5mm	205233	"	"	"	"	"	"	"	"	202295	
	3/16"	323-801-346	"	"	"	"	"	"	"	"	323-870-210	
	6mm	205234	"	"	"	"	"	"	"	"	"	
	1/4"	323-801-347	"	"	"	"	"	"	"	"	"	

504/IV-25

504/IV-43

504/IV-45

*See page 77 for its components.

RIGHT LOOPERS FOR USE WITH VARIOUS SIZE NEEDLES

Right looper		for needle size				Model
Part number	Mark	Singer	W & G	Metric		
204278	323-810-215	1	9-12	027-032	65-80	503/IV
204704	323-810-011	3	13-16	034-040	85-100	
204705	323-810-012	5	17-21	042-051	100-140	

Right looper		for needle size				Model
Part number	Mark	Singer	W & G	Metric		
204062	323-810-218	2	9-12	027-032	65-80	504/IV
204702	323-810-009	4	13-16	034-040	85-100	
204703	323-810-010	6	17-21	042-051	100-140	
204663	323-810-008	7	9-14	027-036	65-90	514/IV

COMMON PARTS: 204072 (323-810-216) – Left looper
201121A (323-870-214) – Upper knife

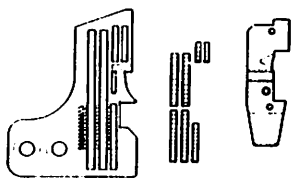
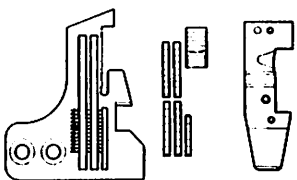
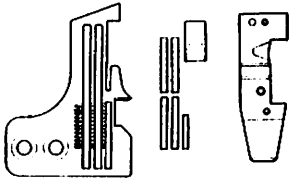
Machine model (Operation)	Gauge (mm) (inch)	Needle plate	Main feed	Differential feed	Auxiliary feed	Presser foot complete	Needle guard (front)	Needle guard (rear)	Needle bar	Right looper	Lower knife	Others	
504/IV-47 Seaming woven and knits 	3mm	205239	204675	204676	204677	*202994	204634	204635	204623	204702	201127		
	1/8"	323-801-360	323-830-029	323-830-033	323-830-037	323-820-282	323-561-009	323-561-010	323-591-003	323-810-009	323-870-211		
	4mm	205240											
	5/32"	323-801-361	"	"	"	"	"	"	"	"	"	Needle (factory setting)	
	5mm	205241											
	3/16"	323-801-362	"	"	"	"	"	"	"	"	202295	DCx27 #16 423244031	
6mm	205242												
1/4"	323-801-363	"	"	"	"	"	"	"	"	"	"		
504/IV-S-10 Seaming jeans 	3mm	202542E	204678	204679	204674	*204956				204703	201127		
	1/8"	323-801-026	323-830-051	323-830-056	323-830-054	323-820-026				323-810-010	323-870-211		
	4mm	202546E											
	5/32"	323-801-027	"	"	"	"	"	"	"	"	"		
	5mm	202596E											
	3/16"	323-801-028	"	"	"	"	"	"	"	"	202295	Needle (factory setting)	
	6mm	202597E									323-870-210	DCx1 #18 423224431	
	1/4"	323-801-029	"	"	"	"	"	"	"	"	"	"	
	7mm	204797											
	9/32"	323-801-042	"	"	"	"	"	"	"	"	"	"	
8mm	204731												
5/16"	323-801-041	"	"	"	"	"	"	"	"	"	"		
504/IV-S-16 Seaming bulky knitwear 	3mm	202542E	204678	204691						204702	201127		
	1/8"	323-801-026	323-830-051	323-830-058						323-810-009	323-870-211		
	4mm	202546E											
	5/32"	323-801-027	"	"	"	"	"	"	"	"	"	Needle (factory setting)	
	5mm	202596E											
	3/16"	323-801-028	"	"	"	"	"	"	"	"	202295	DCx1 #14 423223631	
6mm	202597E									323-870-210			
1/4"	323-801-029	"	"	"	"	"	"	"	"	"	"		

*See page 77 for its components.

RIGHT LOOPERS FOR USE WITH VARIOUS SIZE NEEDLES

Right looper		for needle size				Model
Part number	Mark	Singer	W & G	Metric		
204278	323-810-215	1	9-12	027-032	65-80	503/IV
204704	323-810-011	3	13-16	034-040	85-100	
204705	323-810-012	5	17-21	042-051	100-140	

Right looper		for needle size				Model
Part number	Mark	Singer	W & G	Metric		
204062	323-810-218	2	9-12	027-032	65-80	504/IV
204702	323-810-009	4	13-16	034-040	85-100	
204703	323-810-010	6	17-21	042-051	100-140	
204663	323-810-008	7	9-14	027-036	65-90	514/IV

COMMON PARTS: 204072 (323-810-216) – Left looper
201121A (323-870-214) – Upper knife

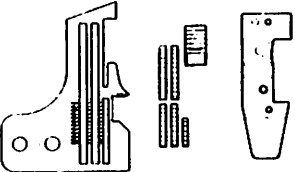
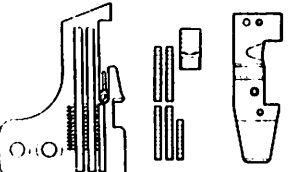
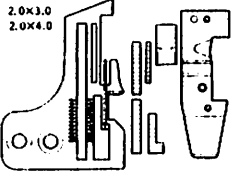
Machine model (Operation)	Gauge (mm) (inch)	Needle plate	Main feed	Differential feed	Auxiliary feed	Presser foot complete	Needle guard (front)	Needle guard (rear)	Needle bar	Right looper	Lower knife	Others
504/IV-S-17 Seaming knits 	3mm 1/8"	202542E 323-801-026	204675 323-830-029	204690 323-830-057	204674 323-830-054	*204956 323-820-026	204634 323-561-009	204635 323-561-010	204623 323-591-003	204062 323-810-218	201127 323-870-211	
	4mm 5/32"	202546E 323-801-027	"	"	"	"	"	"	"	"	"	Needle (factory setting) DCx1 #11 423222831
	5mm 3/16"	202596E 323-801-028	"	"	"	"	"	"	"	"	202295 323-870-210	
	6mm 1/4"	202597E 323-801-029	"	"	"	"	"	"	"	"	"	
514/IV-11 2-needle seaming woven fabrics 	2x2mm 5/64x5/64"	205255 323-801-047	"	204676 323-830-033	"	*204954 323-820-024	204659 323-561-011	204660 323-561-012	204624 323-591-004	204663 323-810-008	201127 323-870-211	
	2x3mm 5/64x1/8"	"	"	"	"	"	"	"	"	"	202295 323-870-210	Needle (factory setting) DCx1 #14 423223631
	2x4mm 5/64x5/32"	202554E 323-801-030	"	"	"	*204955 323-820-025	"	"	"	"	"	
	2x5mm 5/64x3/16"	202499E 323-801-031	"	"	"	"	"	"	"	"	"	
514/IV-12 2-needle seaming woven fabrics 	2x3mm 5/64x1/8"	202702 323-801-070	204692 323-830-030	204693 323-830-034	"	*204954 323-820-024	"	"	"	"	"	
	2x4mm 5/64x5/32"	202675 323-801-315	"	"	"	*204955 323-820-025	"	"	"	"	"	Needle (factory setting) DCx1 #11 423222831
	3x5mm 1/8x3/16"	204914 323-801-046	204838 323-830-042	"	"	*202998 323-820-299	"	"	204837 323-591-006	"	"	

504/IV-S-17

514/IV-11

514/IV-12

cf. left bottom in this page - sketch for 3x5mm gauge

*See page 77 for its components.

514/IV-12

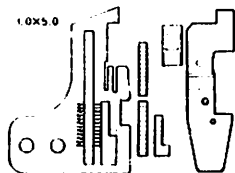

RIGHT LOOPERS FOR USE WITH VARIOUS SIZE NEEDLES

Right looper		for needle size				Model
Part number	Mark	Singer	W & G	Metric		
204278	323-810-215	1	9-12	027-032	65-80	503/IV
204704	323-810-011	3	13-16	034-040	85-100	
204705	323-810-012	5	17-21	042-051	100-140	

Right looper		for needle size				Model
Part number	Mark	Singer	W & G	Metric		
204062	323-810-218	2	9-12	027-032	65-80	504/IV
204702	323-810-009	4	13-16	034-040	85-100	
204703	323-810-010	6	17-21	042-051	100-140	
204663	323-810-008	7	9-14	027-036	65-90	514/IV

COMMON PARTS: 204072 (323-810-216) – Left looper
201121A (323-870-214) – Upper knife

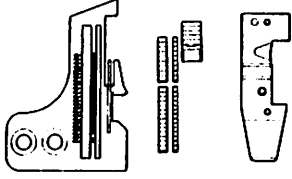
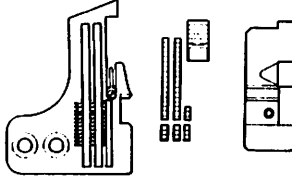
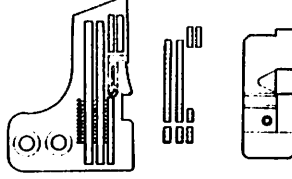
Machine model (Operation)	Gauge (mm) (inch)	Needle plate	Main feed	Differential feed	Auxiliary feed	Presser foot complete	Needle guard (front)	Needle guard (rear)	Needle bar	Right looper	Lower knife	Others
514/IV-20 2-needle seaming light knits 	1.5x2mm 1/16x5/64"	204910 323-801-043	204729 323-830-052	204730 323-830-059	204674 323-830-054	*204954 323-820-024	204659 323-561-011	204660 323-561-012	204872 323-591-007	204663 323-810-008	202295 323-870-210	Needle (factory setting) DCx3 #9
	1.5x3mm 1/16x1/8"	204911 323-801-044	"	"	"	"	"	"	"	"	"	
	2x2mm 5/64x5/64"	205256 323-801-048	"	"	"	"	"	"	204624 323-591-004	"	"	DCx1 #9 423222631
	2x3mm 5/64x1/8"	205257 323-801-049	"	"	"	"	"	"	"	"	"	
514/IV-22 2-needle intermittent shirring. 	2x2mm 5/64x5/64"	205255 323-801-047	204723 323-830-032	204724 323-830-036	"	*204952 323-820-018	"	"	"	"	201127 323-870-211	Needle (factory setting) DCx1 #14 423223631
	2x3mm 5/64x1/8"	"	"	"	"	"	"	"	"	"	202295 323-870-210	
	2x4mm 5/64x5/32"	205554E 323-801-030	"	"	"	"	"	"	"	"	"	Shirring attachment
	2x5mm 5/64x3/16"	202499E 323-801-031	"	"	"	"	"	"	"	"	"	
514/IV-23 2-needle intermittent shirring 	2x4mm 5/64x5/32"	205243 323-801-364	"	"	204677 323-830-037	"	"	"	"	"	"	Needle (factory setting) DCx27 #14 423243631
	2x5mm 5/64x3/16"	205244 323-801-365	"	"	"	"	"	"	"	"	"	

*See page 77 for its components.

RIGHT LOOPERS FOR USE WITH VARIOUS SIZE NEEDLES

Right looper		for needle size			Model
Part number	Mark	Singer	W & G	Metric	
204278 323-810-215	1	9-12	027-032	65-80	503/IV
204704 323-810-011	3	13-16	034-040	85-100	
204705 323-810-012	5	17-21	042-051	100-140	

Right looper		for needle size			Model
Part number	Mark	Singer	W & G	Metric	
204062 323-810-218	2	9-12	027-032	65-80	504/IV
204702 323-810-009	4	13-16	034-040	85-100	
204703 323-810-010	6	17-21	042-051	100-140	
204663 323-810-008	7	9-14	027-036	65-90	514/IV

COMMON PARTS: 204072 (323-810-216) – Left looper
201121A (323-870-214) – Upper knife

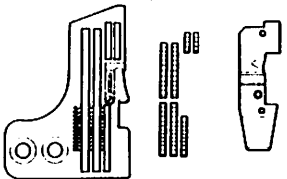
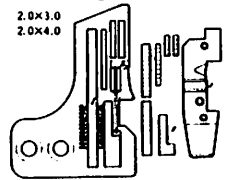
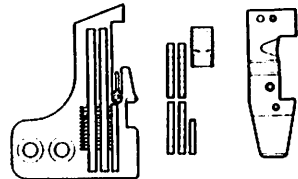
Machine model (Operation)	Gauge (mm) (inch)	Needle plate	Main feed	Differential feed	Auxiliary feed	Presser foot complete	Needle guard (front)	Needle guard (rear)	Needle bar	Right looper	Lower knife	Others
514/IV-41 2-needle seaming on stretch fabrics												
	2x4mm 5/64x5/32"	205243 323-801-364	204675 323-830-029	204676 323-830-033	204677 323-830-037	*202995 323-820-283	204659 323-561-011	204660 323-561-012	204624 323-591-004	204663 323-810-008	202295 323-870-210	Needle (factory setting) DCx27 #14 423243631
	2x5mm 5/64x3/16"	205244 323-801-365	"	"	"	"	"	"	"	"	"	"
514/IV-42 2-needle seaming on stretch fabrics												
	2x3mm 5/64x1/8"	202982 323-801-355	204692 323-830-030	204693 323-830-034	"	*202996 323-820-284	"	"	"	"	"	"
	2x4mm 5/64x5/32"	202983 323-801-356	"	"	"	*202997 323-820-289	"	"	"	"	"	Needle (factory setting) DCx27 #14 423243631
	3x5mm 1/8x3/16"	205245 323-801-357	204838 323-830-042	"	"	*202998 323-820-299	"	"	204837 323-591-006	"	"	"
cf. left bottom in this page - sketch for 3x5mm gauge												
514/IV-S-11 2-needle seaming bulky knits												
	2x3mm 5/64x1/8"	205255 323-801-047	204678 323-830-051	204691 323-830-058	204674 323-830-054	*204954 323-820-024	"	"	204624 323-591-004	"	"	Needle (factory setting) DCx1 #14 423223631
	2x4mm 5/64x5/32"	202554E 323-801-030	"	"	"	*204955 323-820-025	"	"	"	"	"	"

*See page 77 for its components.

514/IV-42

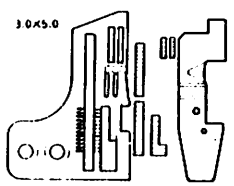

RIGHT LOOPERS FOR USE WITH VARIOUS SIZE NEEDLES

Right looper		for needle size				Model
Part number	Mark	Singer	W & G	Metric		
204278	323-810-215	1	9-12	027-032	65-80	503/IV
204704	323-810-011	3	13-16	034-040	85-100	
204705	323-810-012	5	17-21	042-051	100-140	

Right looper		for needle size				Model
Part number	Mark	Singer	W & G	Metric		
204062	323-810-218	2	9-12	027-032	65-80	504/IV
204702	323-810-009	4	13-16	034-040	85-100	
204703	323-810-010	6	17-21	042-051	100-140	
204663	323-810-008	7	9-14	027-036	65-90	514/IV

514/IV-41

514/IV-42

514/IV-S-11

COMMON PARTS: 204072 (323-810-216) – Left looper
201121A (323-870-214) – Upper knife

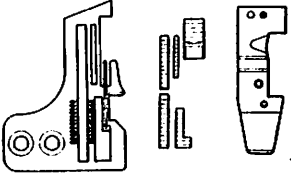
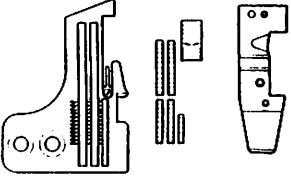
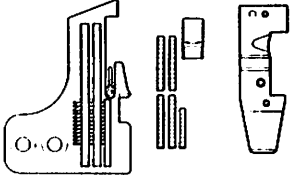
Machine model (Operation)	Gauge (mm) (inch)	Needle . plate	Main feed	Differential feed	Auxiliary feed	Presser foot complete	Needle guard (front)	Needle guard (rear)	Needle bar	Right looper	Lower knife	Others
514/IV-S-13 2-needle seaming light knits 	1.5x2mm 1/16x5/64"	202899 323-801-071	204692 323-830-030	204693 323-830-034	204674 323-830-054	*204954 323-820-024	204659 323-561-011	204660 323-561-012	204872 323-591-007	204663 323-810-008	202295 323-870-210	Needle (factory setting) DCx3 #9
	1.5x3mm 1/16x1/8"	202674 323-801-040	"	"	"	"	"	"	"	"	"	
	2x3mm 5/64x1/8"	202702 323-801-070	"	"	"	"	"	"	204624 323-591-004	"	"	DCx1 #9 423222631
	2x4mm 5/64x5/32"	202675 323-801-315	"	"	"	*204955 323-820-025	"	"	"	"	"	
514/IV-S-14 2-needle seaming knits 	2x2mm 5/64x5/64"	205255 323-801-047	204675 323-830-029	204690 323-830-057	"	*204954 323-820-024	"	"	"	"	201127 323-870-211	Needle (factory setting) DCx1 #11 423222831
	2x3mm 5/64x1/8"	"	"	"	"	"	"	"	"	"	202295 323-870-210	
	2x4mm 5/64x5/32"	202554E 323-801-030	"	"	"	*204955 323-820-025	"	"	"	"	"	
514/IV-S-15 2-needle seaming knits 	2x2mm 5/64x5/64"	205255 323-801-047	"	204676 323-830-033	"	*204954 323-820-024	"	"	"	"	201127 323-870-211	Needle (factory setting) DCx1 #9 423222631
	2x3mm 5/64x1/8"	"	"	"	"	"	"	"	"	"	202295 323-870-210	
	2x4mm 5/64x5/32"	202554E 323-801-030	"	"	"	*204955 323-820-025	"	"	"	"	"	

*See page 77 for its components.

RIGHT LOOPERS FOR USE WITH VARIOUS SIZE NEEDLES

Right looper		for needle size			Model	
Part number	Mark	Singer	W & G	Metric		
204278	323-810-215	1	9-12	027-032	65-80	503/IV
204704	323-810-011	3	13-16	034-040	85-100	
204705	323-810-012	5	17-21	042-051	100-140	

Right looper		for needle size			Model	
Part number	Mark	Singer	W & G	Metric		
204062	323-810-218	2	9-12	027-032	65-80	504/IV
204702	323-810-009	4	13-16	034-040	85-100	
204703	323-810-010	6	17-21	042-051	100-140	
204663	323-810-008	7	9-14	027-036	65-90	

COMMON PARTS: 204072 (323-810-216) – Left looper
201121A (323-870-214) – Upper knife

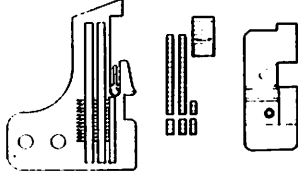
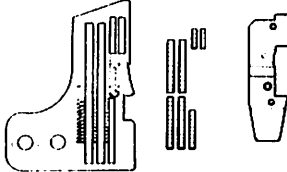
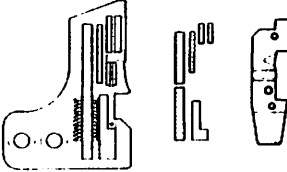
Machine model (Operation)	Gauge (mm) (inch)	Needle plate	Main feed	Differential feed	Auxiliary feed	Presser foot complete	Needle guard (front)	Needle guard (rear)	Needle bar	Right looper	Lower knife	Others	
514/IV-S-18 2-needle intermittent shirring 	2x2mm 5/64x5/64"	205255 323-801-047	204723 323-830-032	204724 323-830-036	204674 323-830-054	*204952 323-820-018	204659 323-561-011	204660 323-561-012	204624 323-591-004	204663 323-810-008	201127 323-870-211	Needle (factory setting) DCx1 #14 423223631 Shirring attachment	
	2x3mm 5/64x1/8"	"	"	"	"	"	"	"	"	"	202295 323-870-210		
	2x4mm 5/64x5/32"	202554E 323-801-030	"	"	"	"	"	"	"	"	"		
514/IV-S-19 2-needle seaming 	2x4mm 5/64x5/32"	205243 323-801-364	204675 323-830-029	204676 323-830-033	204677 323-830-037	*202995 323-820-283	"	"	"	"	"	Needle (factory setting) DCx1 #14 423223631	
514/IV-S-20 2-needle seaming 	1.5x3mm 1/16x1/8"	202981 323-801-354	204692 323-830-030	204693 323-830-034	"	*202996 323-820-284	"	"	204872 323-591-007	"	"	Needle (factory setting) DCx3 #9 DCx1 #11 423222831	
	2x3mm 5/64x1/8"	202982 323-801-355	"	"	"	"	"	"	204624 323-591-004	"	"		
	2x4mm 5/64x5/32"	202983 323-801-356	"	"	"	"	*202997 323-820-289	"	"	"	"		

514/IV-S-18

514/IV-S-19

514/IV-S-20

*See page 77 for its components.

RIGHT LOOPERS FOR USE WITH VARIOUS SIZE NEEDLES

Right looper		for needle size				Model
Part number	Mark	Singer	W & G	Metric		
204278	323-810-215	1	9-12	027-032	65-80	503/IV
204704	323-810-011	3	13-16	034-040	85-100	
204705	323-810-012	5	17-21	042-051	100-140	

Right looper		for needle size				Model
Part number	Mark	Singer	W & G	Metric		
204062	323-810-218	2	9-12	027-032	65-80	504/IV
204702	323-810-009	4	13-16	034-040	85-100	
204703	323-810-010	6	17-21	042-051	100-140	
204663	323-810-008	7	9-14	027-036	65-90	514/IV

COMPONENT PARTS – PRESSER FOOT COMPLETE

Presser foot complete	body	chaining-off finger	chaining-off finger screw	hinge spring	fabric guard	fabric guard screw	uncurler	uncurler screw
202992 323-820-280	205252 323-820-285	201224B 323-863-007	5089 323-600-050	201156 323-643-001	201265B 323-854-200	1231 323-600-051	205342 323-560-021	5030 323-600-202
202993 323-820-281	202799 323-820-286	"	"	"	"	"	"	"
202994 323-820-282	205253 323-820-287	"	"	"	"	"	"	"
202995 323-820-283	"	201310A 323-863-201	"	"	"	"	"	"
202996 323-820-284	202799 323-820-286	201396B 323-863-215	"	"	"	"	"	"
202997 323-820-289	"	201310A 323-863-201	"	"	"	"	"	"
202998 323-820-299	205254 323-820-288	201461A 323-863-216	"	"	"	"	"	"
204951 323-820-017	205135 323-820-013	---	"	"	---	---	"	"
204952 323-820-018	205136 323-820-014	---	"	"	---	---	"	"
204953 323-820-023	201473B 323-820-022	201224B 323-863-007	"	"	---	---	"	"
204954 323-820-024	201230C 323-820-019	201396B 323-863-215	"	"	201265B 323-854-200	1231 323-600-051	204668 323-560-020	"
204955 323-820-025	"	201310A 323-863-201	"	"	"	"	"	"
204956 323-820-026	"	201224B 323-863-007	"	"	"	"	"	"
205226 323-820-220	201152E 323-820-021	201155C 323-863-217	"	"	---	---	205342 323-560-021	"

COMMON PARTS: 204782 (323-561-014) – Needle guard (front) for right needle
 204781 (323-561-013) – Needle guard (rear) for right needle
 204072 (323-810-216) – Left looper
 204161 (323-870-213) – Lower knife

Machine model (Operation)	Gauge (mm) (inch)	Needle plate	Main feed	Differential feed	Presser foot complete	Presser foot fabric guard	Needle guard for 401 needle (front)	Needle guard (rear)	Needle bar complete	Right looper	401 looper	Upper knife	Others	
515/IV-26 516/IV-26 General seaming on woven and knit fabrics	2x3mm 5/64x1/8"	204343A 323-801-255	204248B 323-830-314	204250B 323-830-316	204349A 323-820-255	204173A 323-560-221	204536 323-561-211	204521 323-561-219	204877 323-843-001	204278 323-810-215	204314A 323-810-217	201121A 323-870-214	Needle (factory setting) DCx27 #11 423242831	
	2x4mm 5/64x5/32"	204344A 323-801-256	"	"	"	"	"	"	"	"	"	"		
	2x5mm 5/64x3/16"	204345A 323-801-257	"	"	"	"	"	"	"	"	"	"		
	2x6mm 5/64x1/4"	204346A 323-801-258	"	"	"	"	"	"	"	"	"	"		
	3x3mm 1/8x1/8"	204294B 323-801-275	"	"	204167B 323-820-260	"	204042 323-561-218	204522 323-561-220	204878 323-843-002	204704 323-810-011	"	"		
	3x4mm 1/8x5/32"	204039B 323-801-276	"	"	"	"	"	"	"	"	"	"		
	3x5mm 1/8x3/16"	204252B 323-801-277	"	"	"	"	"	"	"	"	"	"		
	3x6mm 1/8x1/4"	204295B 323-801-278	"	"	"	"	"	"	"	"	"	"		DCx27 #14 423243631
	5x3mm 3/16x1/8"	204358A 323-801-263	"	"	204433A 323-820-257	"	"	"	204879 323-843-003	"	204431 323-810-219	"		
	5x4mm 3/16x5/32"	204359A 323-801-264	"	"	"	"	"	"	"	"	"	"		
	5x5mm 3/16x3/16"	204360A 323-801-310	"	"	"	"	"	"	"	"	"	"		
	5x6mm 3/16x1/4"	204361A 323-801-266	"	"	"	"	"	"	"	"	"	"		
515/IV-27 516/IV-27 General seaming and serging on light weight materials	2x3mm 5/64x1/8"	204362 323-801-267	204395 323-830-244	204409 323-830-243	204440 323-820-258	204447 323-560-234	204536 323-561-211	204521 323-561-219	204877 323-843-001	204278 323-810-215	204314A 323-810-217	202527 323-870-207		
	2x4mm 5/64x5/32"	204363 323-801-268	"	"	"	"	"	"	"	"	"	"		
	2x5mm 5/64x3/16"	204364 323-801-269	"	"	"	"	"	"	"	"	"	"		
	2x6mm 5/64x1/4"	204365 323-801-270	"	"	"	"	"	"	"	"	"	"	Needle (factory setting) DCx27 #11 423242831	
	3x3mm 1/8x1/8"	204366 323-801-271	"	"	204443 323-820-259	"	204042 323-561-218	204522 323-561-220	204878 323-843-002	"	"	"		
	3x4mm 1/8x5/32"	204367 323-801-272	"	"	"	"	"	"	"	"	"	"		
	3x5mm 1/8x3/16"	204368 323-801-273	"	"	"	"	"	"	"	"	"	"		
	3x6mm 1/8x1/4"	204369 323-801-274	"	"	"	"	"	"	"	"	"	"		

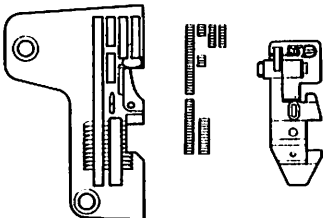
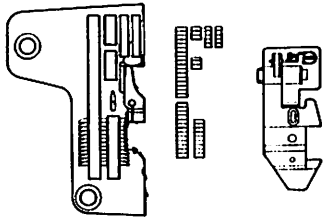

RIGHT LOOPERS FOR USE WITH VARIOUS SIZE NEEDLES

Right looper		for needle size			Model
Part number	Mark	Singer	W & G	Metric	
204278	323-810-215	1	9-12	027-032	515/IV
204704	323-810-011	3	13-16	034-040	
204705	323-810-012	5	17-21	042-051	

Right looper		for needle size			Model
Part number	Mark	Singer	W & G	Metric	
204062	323-810-218	2	9-12	027-032	516/IV
204702	323-810-009	4	13-16	034-040	
204703	323-810-010	6	17-21	042-051	

515/IV-26 515/IV-27
 516/IV-26 516/IV-27

COMMON PARTS: 204782 (323-561-014) – Needle guard (front) for right needle
 204781 (323-561-013) – Needle guard (rear) for right needle
 204072 (323-810-216) – Left looper
 204161 (323-870-213) – Lower knife

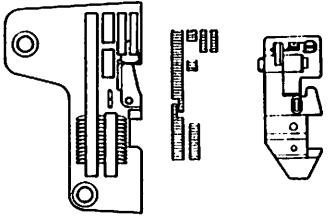
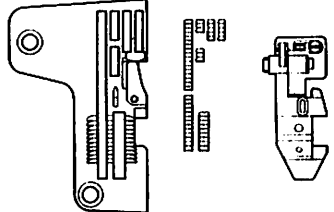
Machine model (Operation)	Gauge (mm) (inch)	Needle plate	Main feed	Differential feed	Presser foot complete	Presser foot fabric guard	Needle guard for 401 needle (front)	Needle guard (rear)	Needle bar complete	Right looper	401 looper	Upper knife	Others	
515/IV-28 516/IV-28 General seaming on permanent- press fabrics 	2x3mm 5/64x1/8"	204343A 323-801-255	204125B 323-830-237	204254B 323-830-238	204349A 323-820-255	204173A 323-560-221	204536 323-561-211	204521 323-561-219	204877 323-843-001	204278 323-810-215	204314A 323-810-217	201121A 323-870-214		
	2x4mm 5/64x5/32"	204344A 323-801-256	"	"	"	"	"	"	"	"	"	"	"	
	2x5mm 5/64x3/16"	204345A 323-801-257	"	"	"	"	"	"	"	"	"	"	"	
	2x6mm 5/64x1/4"	204346A 323-801-258	"	"	"	"	"	"	"	"	"	"	"	
	3x3mm 1/8x1/8"	204294B 323-801-275	"	"	204167B 323-820-260	"	204042 323-561-218	204522 323-561-220	204878 323-843-002	"	"	"	"	Needle (factory setting) DCx27 #11 423242831
	3x4mm 1/8x5/32"	204039B 323-801-276	"	"	"	"	"	"	"	"	"	"	"	
	3x5mm 1/8x3/16"	204252B 323-801-277	"	"	"	"	"	"	"	"	"	"	"	
	3x6mm 1/8x1/4"	204295B 323-801-278	"	"	"	"	"	"	"	"	"	"	"	
	515/IV-29 516/IV-29 General seaming and serging on light to medium weight woven and knit fabrics 	2x3mm 5/64x1/8"	204362 323-801-267	204396 323-830-248	204410 323-830-247	204440 323-820-258	204447 323-560-234	204536 323-561-211	204521 323-561-219	204877 323-843-001	"	"	202527 323-870-207	
2x4mm 5/64x5/32"		204363 323-801-268	"	"	"	"	"	"	"	"	"	"	Needle (factory setting) DCx27 #11 423242831	
2x5mm 5/64x3/16"		204364 323-801-269	"	"	"	"	"	"	"	"	"	"		
2x6mm 5/64x1/4"		204365 323-801-270	"	"	"	"	"	"	"	"	"	"		
3x3mm 1/8x1/8"		204366 323-801-271	"	"	204443 323-820-259	"	204042 323-561-218	204522 323-561-220	204878 323-843-002	204704 323-810-011	"	"		
3x4mm 1/8x5/32"		204367 323-801-272	"	"	"	"	"	"	"	"	"	"	DCx27 #14 423243631	
3x5mm 1/8x3/16"		204368 323-801-273	"	"	"	"	"	"	"	"	"	"		
3x6mm 1/8x1/4"		204369 323-801-274	"	"	"	"	"	"	"	"	"	"		

RIGHT LOOPERS FOR USE WITH VARIOUS SIZE NEEDLES

Right looper		for needle size			Model
Part number	Mark	Singer	W & G	Metric	
204278 323-810-215	1	9-12	027-032	65-80	515/IV
204704 323-810-011	3	13-16	034-040	85-100	
204705 323-810-012	5	17-21	042-051	100-140	

Right looper		for needle size			Model
Part number	Mark	Singer	W & G	Metric	
204062 323-810-218	2	9-12	027-032	65-80	516/IV
204702 323-810-009	4	13-16	034-040	85-100	
204703 323-810-010	6	17-21	042-051	100-140	

COMMON PARTS: 204782 (323-561-014) – Needle guard (front) for right needle
 204781 (323-561-013) – Needle guard (rear) for right needle
 204072 (323-810-216) – Left looper
 204161 (323-870-213) – Lower knife

Machine model (Operation)	Gauge (mm) (inch)	Needle plate	Main feed	Differential feed	Presser foot complete	Presser foot fabric guard	Needle guard for 401 needle (front)	Needle guard (rear)	Needle bar complete	Right looper	401 looper	Upper knife	Others
515/IV-31 516/IV-31 Seaming on coarse woven fabrics	2x3mm	204370	204400	204414	204349A	204173A	204536	204521	204877	204704	204314A	201121A	
	5/64x1/8"	323-801-279	323-830-260	323-830-259	323-820-255	323-560-221	323-561-211	323-561-219	323-843-001	323-810-011	323-810-217	323-870-214	
	2x4mm	204371	"	"	"	"	"	"	"	"	"	"	
	5/64x5/32"	323-801-280	"	"	"	"	"	"	"	"	"	"	
	2x5mm	204372	"	"	"	"	"	"	"	"	"	"	
	5/64x3/16"	323-801-281	"	"	"	"	"	"	"	"	"	"	
	2x6mm	204373	"	"	"	"	"	"	"	"	"	"	
	5/64x1/4"	323-801-282	"	"	"	"	"	"	"	"	"	"	
	3x3mm	204374	"	"	204167B	"	204042	204522	204878	"	"	"	
	1/8x1/8"	323-801-283	"	"	323-820-260	"	323-561-218	323-561-220	323-843-002	"	"	"	
	3x4mm	204375	"	"	"	"	"	"	"	"	"	"	Needle (factory setting)
	1/8x5/32"	323-801-284	"	"	"	"	"	"	"	"	"	"	DCx27 #16 423244031
	3x5mm	204376	"	"	"	"	"	"	"	"	"	"	
	1/8x3/16"	323-801-285	"	"	"	"	"	"	"	"	"	"	
	3x6mm	204377	"	"	"	"	"	"	"	"	"	"	
1/8x1/4"	323-801-286	"	"	"	"	"	"	"	"	"	"		
5x3mm	204378	204394	204416	204433A	"	"	"	204879	"	204431	"		
3/16x1/8"	323-801-287	323-830-262	323-830-261	323-820-257	"	"	"	323-843-003	"	323-810-219	"		
5x4mm	204379	"	"	"	"	"	"	"	"	"	"		
3/16x5/32"	323-801-288	"	"	"	"	"	"	"	"	"	"		
5x5mm	204380	"	"	"	"	"	"	"	"	"	"		
3/16x3/16"	323-801-289	"	"	"	"	"	"	"	"	"	"		
5x6mm	204381	"	"	"	"	"	"	"	"	"	"		
3/16x1/4"	323-801-290	"	"	"	"	"	"	"	"	"	"		
515/IV-32 516/IV-32 General seaming on medium- heavy woven materials	3x3mm	204366	204397	204411	204443	204447	"	"	204878	"	204314A	202527	
	1/8x1/8"	323-801-271	323-830-264	323-830-263	323-820-259	323-560-234	"	"	323-843-002	"	323-810-217	323-870-207	
	3x4mm	204367	"	"	"	"	"	"	"	"	"	"	
	1/8x5/32"	323-801-272	"	"	"	"	"	"	"	"	"	"	
	3x5mm	204368	"	"	"	"	"	"	"	"	"	"	Needle (factory setting)
	1/8x3/16"	323-801-273	"	"	"	"	"	"	"	"	"	"	DCx27 #16 423244031
3x6mm	204369	"	"	"	"	"	"	"	"	"	"		
1/8x1/4"	323-801-274	"	"	"	"	"	"	"	"	"	"		

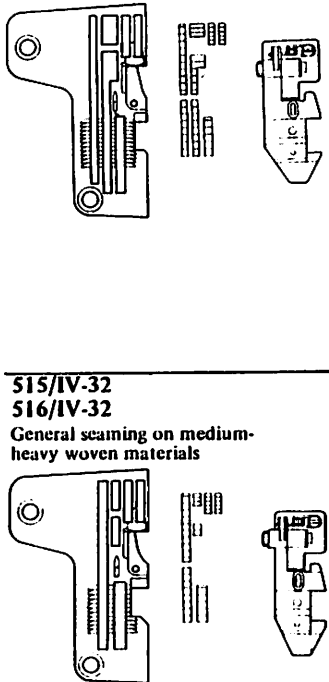

RIGHT LOOPERS FOR USE WITH VARIOUS SIZE NEEDLES

Right looper		Mark	for needle size			Model
Part number	Mark		Singer	W & G	Metric	
204278	323-810-215	1	9-12	027-032	65-80	515/IV
204704	323-810-011	3	13-16	034-040	85-100	
204705	323-810-012	5	17-21	042-051	100-140	

Right looper		Mark	for needle size			Model
Part number	Mark		Singer	W & G	Metric	
204062	323-810-218	2	9-12	027-032	65-80	516/IV
204702	323-810-009	4	13-16	034-040	85-100	
204703	323-810-010	6	17-21	042-051	100-140	

515/IV-31 515/IV-32
 516/IV-31 516/IV-32

COMMON PARTS: 204782 (323-561-014) – Needle guard (front) for right needle
 204781 (323-561-013) – Needle guard (rear) for right needle
 204072 (323-810-216) – Left looper
 204161 (323-870-213) – Lower knife

Machine model (Operation)	Gauge (mm) (inch)	Needle plate	Main feed	Differential feed	Presser foot complete	Presser foot fabric guard	Needle guard for 401 needle (front)	Needle guard (rear)	Needle bar complete	Right looper	401 looper	Upper knife	Others
515/IV-33 516/IV-33 Seaming and turning corners on coarse woven materials	3x3mm	204294B	204394	204408	204167B	204173A	204042	204522	204878	204704	204314A	201121A	
	1/8x1/8"	323-801-275	323-830-262	323-830-267	323-820-260	323-560-221	323-561-218	323-561-220	323-843-002	323-810-011	323-810-217	323-870-214	
	3x4mm	204039B	"	"	"	"	"	"	"	"	"	"	
	1/8x5/32"	323-801-276	"	"	"	"	"	"	"	"	"	"	
	3x5mm	204252B	"	"	"	"	"	"	"	"	"	"	
	1/8x3/16"	323-801-277	"	"	"	"	"	"	"	"	"	"	
	3x6mm	204295B	"	"	"	"	"	"	"	"	"	"	
	1/8x1/4"	323-801-278	"	"	"	"	"	"	"	"	"	"	
	5x3mm	204358A	"	"	204433A	"	"	"	204879	"	204431	"	Needle (factory setting)
	3/16x1/8"	323-801-263	"	"	323-820-257	"	"	"	323-843-003	"	323-810-219	"	DCx27 #16 423244031
	5x4mm	204359A	"	"	"	"	"	"	"	"	"	"	
	3/16x5/32"	323-801-264	"	"	"	"	"	"	"	"	"	"	
	5x5mm	204360A	"	"	"	"	"	"	"	"	"	"	
	3/16x3/16"	323-801-310	"	"	"	"	"	"	"	"	"	"	
5x6mm	204361A	"	"	"	"	"	"	"	"	"	"		
3/16x1/4"	323-801-266	"	"	"	"	"	"	"	"	"	"		
515/IV-38 516/IV-38 3:1 intermittent (knee controlled) shirring on dress weight materials	2x3mm	204935	204931	204420	204454	204460	204536	204521	204877	204278	204314A	"	Needle (factory setting)
	5/64x1/8"	323-801-050	323-830-061	323-830-291	323-820-271	323-560-235	323-561-211	323-561-219	323-843-001	323-810-215	323-810-217	"	DCx27 #11 423242831
	2x4mm	204936	"	"	"	"	"	"	"	"	"	"	
	5/64x5/32"	323-801-051	"	"	"	"	"	"	"	"	"	"	
	2x5mm	204937	"	"	"	"	"	"	"	"	"	"	
	5/64x3/16"	323-801-052	"	"	"	"	"	"	"	"	"	"	
	2x6mm	204938	"	"	"	"	"	"	"	"	"	"	
	5/64x1/4"	323-801-053	"	"	"	"	"	"	"	"	"	"	Shirring attachment
	3x3mm	204939	"	"	204456	"	204042	204522	204878	204704	"	"	
	1/8x1/8"	323-801-054	"	"	323-820-272	"	323-561-218	323-561-220	323-843-002	323-810-011	"	"	
	3x4mm	204940	"	"	"	"	"	"	"	"	"	"	
	1/8x5/32"	323-801-055	"	"	"	"	"	"	"	"	"	"	
	3x5mm	204941	"	"	"	"	"	"	"	"	"	"	
	1/8x3/16"	323-801-056	"	"	"	"	"	"	"	"	"	"	
3x6mm	204942	"	"	"	"	"	"	"	"	"	"		
1/8x1/4"	323-801-057	"	"	"	"	"	"	"	"	"	"		
5x3mm	204943	204933	204422	204458	"	"	"	204879	"	204431	"	DCx27 #14 423243631	
3/16x1/8"	323-801-058	323-830-063	323-830-295	323-820-273	"	"	"	323-843-003	"	323-810-219	"		
5x4mm	204944	"	"	"	"	"	"	"	"	"	"		
3/16x5/32"	323-801-059	"	"	"	"	"	"	"	"	"	"		
5x5mm	204945	"	"	"	"	"	"	"	"	"	"		
3/16x3/16"	323-801-060	"	"	"	"	"	"	"	"	"	"		
5x6mm	204946	"	"	"	"	"	"	"	"	"	"		
3/16x1/4"	323-801-061	"	"	"	"	"	"	"	"	"	"		

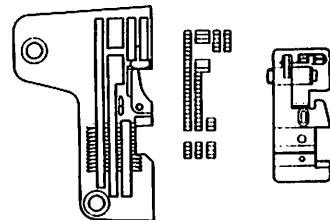
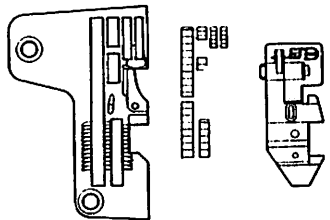

RIGHT LOOPERS FOR USE WITH VARIOUS SIZE NEEDLES

Right looper		for needle size			Model
Part number	Mark	Singer	W & G	Metric	
204278	323-810-215	1	9-12	027-032	515/IV
204704	323-810-011	3	13-16	034-040	
204705	323-810-012	5	17-21	042-051	

Right looper		for needle size			Model
Part number	Mark	Singer	W & G	Metric	
204062	323-810-218	2	9-12	027-032	516/IV
204702	323-810-009	4	13-16	034-040	
204703	323-810-010	6	17-21	042-051	

COMMON PARTS: 204782 (323-561-014) -- Needle guard (front) for right needle
 204781 (323-561-013) -- Needle guard (rear) for right needle
 204072 (323-810-216) -- Left looper
 204161 (323-870-213) -- Lower knife

515/IV-39
 516/IV-39
 515/IV-51
 516/IV-51
 515/IV-52
 516/IV-52

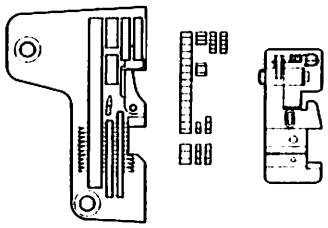
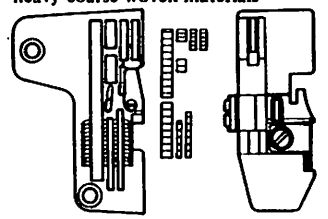
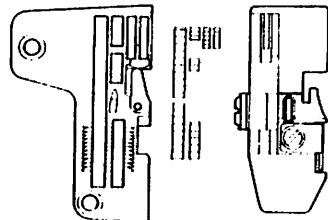
Machine model (Operation)	Gauge (mm) (inch)	Needle plate	Main feed	Differential feed	Presser foot complete	Presser foot fabric guard	Needle guard for 401 needle (front)	Needle guard (rear)	Needle bar complete	Right looper	401 looper	Upper knife	Others	
515/IV-39 516/IV-39 3:1 intermittent (knee controlled) shirring on medium heavy materials	2x3mm	204935	204932	204421	204454	204460	204536	204521	204877	204278	204314A	201121A		
	5/64x1/8"	323-801-050	323-830-062	323-830-245	323-820-271	323-560-235	323-561-211	323-561-219	323-843-001	323-810-215	323-810-217	323-870-214		
	2x4mm	204936	"	"	"	"	"	"	"	"	"	"	Needle (factory setting)	
	5/64x5/32"	323-801-051	"	"	"	"	"	"	"	"	"	"	DCx27 #16	
	2x5mm	204937	"	"	"	"	"	"	"	"	"	"	423244031	
	5/64x3/16"	323-801-052	"	"	"	"	"	"	"	"	"	"		
	2x6mm	204938	"	"	"	"	"	"	"	"	"	"		
	5/64x1/4"	323-801-053	"	"	"	"	"	"	"	"	"	"		
	3x3mm	204939	"	"		204456	"	204042	204522	204878	204704	"	"	
	1/8x1/8"	323-801-054	"	"		323-820-272	"	323-561-218	323-561-220	323-843-002	323-810-011	"	"	
	3x4mm	204940	"	"	"	"	"	"	"	"	"	"	Shirring attachment	
	1/8x5/32"	323-801-055	"	"	"	"	"	"	"	"	"	"		
	3x5mm	204941	"	"	"	"	"	"	"	"	"	"		
	1/8x3/16"	323-801-056	"	"	"	"	"	"	"	"	"	"		
	3x6mm	204942	"	"	"	"	"	"	"	"	"	"		
	1/8x1/4"	323-801-057	"	"	"	"	"	"	"	"	"	"		
	5x3mm	204943	204934	204423	204458	"	"	"	204879	"	204431	"		
	3/16x1/8"	323-801-058	323-830-064	323-830-297	323-820-273	"	"	"	323-843-003	"	323-810-219	"		
5x4mm	204944	"	"	"	"	"	"	"	"	"	"			
3/16x5/32"	323-801-059	"	"	"	"	"	"	"	"	"	"			
5x5mm	204945	"	"	"	"	"	"	"	"	"	"			
3/16x3/16"	323-801-060	"	"	"	"	"	"	"	"	"	"			
5x6mm	204946	"	"	"	"	"	"	"	"	"	"			
3/16x1/4"	323-801-061	"	"	"	"	"	"	"	"	"	"			
														
515/IV-51 516/IV-51 Seaming and crossing seams on heavy coarse woven materials	5x5mm	204700	204394	204416	204915	204683	"	"	"	204705	"	"	Needle (factory setting)	
	3/16x3/16"	323-801-034	323-830-262	323-830-261	323-820-027	323-560-029	"	"	"	323-810-012	"	"	DCx1 #21	
	5x6mm	204701	"	"	"	"	"	"	"	"	"	"	(B-27 #120)	
	3/16x1/4"	323-801-035	"	"	"	"	"	"	"	"	"	"	423225231	
														
515/IV-52 516/IV-52 Seaming and crossing seams on heavy coarse woven materials	5x5mm	204528	"	204408	"	"	"	"	"	"	"	"	Needle (factory setting)	
	3/16x3/16"	323-801-358	"	323-830-267	"	"	"	"	"	"	"	"	DCx1 #21	
	5x6mm	204529	"	"	"	"	"	"	"	"	"	"	(B-27 #120)	
3/16x1/4"	323-801-359	"	"	"	"	"	"	"	"	"	"	423225231		
														

See page 81 for RIGHT LOOPER REFERENCE TABLE

CROSS NUMBER INDEX

(Index with old numbers listed numerically begins on page 91)

NEW PRODUCT CODE NO.	OLD NO.	PAGE	REF NO.	NEW PRODUCT CODE NO.	OLD NO.	PAGE	REF NO.	NEW PRODUCT CODE NO.	OLD NO.	PAGE	REF NO.
323-400-001	201211A	59	15	323-535-001	216	65	1	323-561-218	204042	78	
323-500-004	204850	21	9	323-535-002	218	65	3	323-561-218	204042	79	
323-500-006	204622A	21	5	323-535-003	232	65	18	323-561-218	204042	80	
323-502-007	204640A	51	2	323-535-205	204029	33	1	323-561-218	204042	81	
323-502-209	204163A	51	1	323-535-212	204134A	45	24	323-561-218	204042	82	
323-502-213	204139A	45	34	323-540-015	204733	31	1	323-561-219	204521	78	
323-505-009	240	65	36	323-540-016	204751	47	1	323-561-219	204521	79	
323-505-010	204760	59	13	323-540-017	204752	45	29	323-561-219	204521	80	
323-505-011	303037	59	19	323-540-024	204874	43	13	323-561-219	204521	81	
323-505-100	197	57	49	323-540-225	204079	41	9	323-561-219	204521	82	
323-508-002	201341	53	19	323-540-228	204069A	37	12	323-561-220	204522	78	
323-508-004	204739	21	2	323-540-228	204069A	39	12	323-561-220	204522	79	
323-508-007	204000B	21	1	323-540-232	204031	33	9	323-561-220	204522	80	
323-508-008	303080	61	2	323-540-233	204078	41		323-561-220	204522	81	
323-508-009	303030	61	19	323-540-233	204078	45		323-561-220	204522	82	
323-510-030	204650A	25	26	323-540-234	204080	41	10	323-568-202	204198	55	20
323-510-030	204650A	29	29	323-540-236	204184	53	9	323-570-203	204186	53	13
323-510-031	204857	55	35	323-540-237	204183	53	7	323-570-204	204187	53	11
323-510-032	204865	55	30	323-540-240	204164	51	44	323-576-004	201360A	33	5
323-510-046	208003	29	17	323-540-246	205067	57	7	323-576-005	201441A	33	6
323-510-048	208005	29	19	323-546-203	204025	31	30	323-576-006	204787	39	7
323-510-050	208002	25	15	323-546-204	204026	31	33	323-576-007	204788	39	8
323-510-051	208023	25	3	323-560-012	204712	47	48	323-576-213	204048A	39	9
323-510-051	208023	29	5	323-560-014	204799	25	28	323-576-215	204110A	47	7
323-510-052	208000	25	16	323-560-014	204799	29	31	323-576-217	204332	37	6
323-510-052	208000	29	16	323-560-015	204849	21	14	323-576-218	202607	35	1
323-510-053	208058	29	18	323-560-016	204848	25	1	323-576-219	204076	41	7
323-510-054	208012	25	14	323-560-016	204848	29	1	323-576-220	204085	45	5
323-510-237	204212A	23	13	323-560-020	204668	77		323-576-225	204517	43	11
323-510-237	204212A	27	14	323-560-021	205342	77		323-580-208	204077	41	28
323-510-240	202615	35	34	323-560-027	303075	61	5	323-580-210	204086B	45	16
323-510-245	204028	31	38	323-560-028	303036	61	22	323-580-211	204101A	45	10
323-510-247	204208	23	6	323-560-029	204683	82		323-590-003	234	65	24
323-510-247	204208	27	7	323-560-221	204173A	78		323-591-003	204623	68	
323-510-248	204223	25	7	323-560-221	204173A	79		323-591-003	204623	69	
323-510-248	204223	29	9	323-560-221	204173A	80		323-591-003	204623	70	
323-510-251	204224	25	10	323-560-221	204173A	80		323-591-003	204623	71	
323-510-251	204224	29	12	323-560-225	204156	49	49	323-591-003	204623	72	
323-510-263	204119A	47	24	323-560-234	204447	78		323-591-004	204624	73	
323-510-265	204210A	23	10	323-560-234	204447	79		323-591-004	204624	74	
323-510-265	204210A	27	11	323-560-234	204447	80		323-591-004	204624	75	
323-515-002	204737	31	6	323-560-235	204460	81		323-591-004	204624	76	
323-515-004	204881	31	5	323-560-235	204460	82		323-591-006	204837	72	
323-515-202	204060	37	34	323-561-009	204634	68		323-591-006	204837	74	
323-515-203	204180	53	1	323-561-009	204634	69		323-591-007	204872	73	
323-518-202	204116A	47	19	323-561-009	204634	70		323-591-007	204872	75	
323-525-229	204055A	37	21	323-561-009	204634	71		323-591-007	204872	76	
323-525-230	204047	39	1	323-561-009	204634	72		323-593-003	204123A	47	33
323-525-231	204075	41	1	323-561-010	204635	68		323-593-207	204124	47	34
323-525-232	204100	45	1	323-561-010	204635	70		323-600-001	5078	21	7
323-525-233	204112	47	12	323-561-010	204635	71		323-600-002	1175-2	37	36
323-525-234	204122	47	29	323-561-010	204635	72		323-600-002	1175-2	47	53
323-525-235	204145	49	1	323-561-011	204659	72		323-600-002	1175-2	47	57
323-525-236	204147	49	5	323-561-011	204659	73		323-600-002	1175-2	49	18
323-525-239	204082A	43	1	323-561-011	204659	74		323-600-002	1175-2	49	30
323-530-010	204664	39	19	323-561-011	204659	75		323-600-002	1175-2	59	14
323-530-011	204755	45	39	323-561-011	204659	76		323-600-004	5060	49	11
323-530-016	204177B	51	60	323-561-012	204660	72		323-600-004	5060	53	12
323-530-017	204853	39	20	323-561-012	204660	73		323-600-006	1234	25	6
323-530-018	204883	45	41	323-561-012	204660	74		323-600-006	1234	29	8
323-530-022	303049	59	36	323-561-012	204660	75		323-600-008	5080	31	31
323-530-100	193	57	39	323-561-012	204660	76		323-600-009	5081	31	32
323-530-224	204057A	37	27	323-561-013	204781	33	22	323-600-010	5010	31	37
323-530-225	204071	39	18	323-561-014	204782	33	24	323-600-010	5010	49	31
323-530-226	204093	41	21	323-561-017	204884	33	38	323-600-011	5002	23	24
323-530-229	204166	51	47	323-561-211	204536	78		323-600-011	5002	49	25
323-530-232	205072	57	22	323-561-211	204536	79		323-600-012	1457	35	26
323-530-233	202644A	51	54	323-561-211	204536	80		323-600-012	1457	35	28
323-533-005	245	63	16	323-561-211	204536	81		323-600-012	1457	35	35
323-534-001	204592	57	26	323-561-211	204536	82		323-600-012	1457	37	4

CROSS NUMBER INDEX

(Index with old numbers listed numerically begins on page 91)

NEW PRODUCT CODE NO.	OLD NO.	PAGE	REF NO.	NEW PRODUCT CODE NO.	OLD NO.	PAGE	REF NO.	NEW PRODUCT CODE NO.	OLD NO.	PAGE	REF NO.
323-600-012	1457	43	36	323-600-037	1458	53	10	323-600-072	5094	25	27
323-600-013	5084	23	19	323-600-038	5095	25	12	323-600-072	5094	29	13
323-600-013	5084	27	41	323-600-038	5095	29	14	323-600-072	5094	29	27
323-600-013	5084	33	13	323-600-039	5113	35	33	323-600-072	5094	29	30
323-600-013	5084	37	9	323-600-039	5113	43	30	323-600-072	5094	53	16
323-600-013	5084	37	26	323-600-039	5113	43	34	323-600-074	2905	59	16
323-600-013	5084	37	33	323-600-039	5113	55	34	323-600-074	2905	61	12
323-600-013	5084	41	17	323-600-039	5113	61	46	323-600-075	1732	35	48
323-600-013	5084	43	17	323-600-040	5087	33	7	323-600-079	5184	59	10
323-600-013	5084	45	3	323-600-041	1457-1	37	31	323-600-083	5321A	45	46
323-600-013	5084	45	33	323-600-043	2022	21	4	323-600-084	204590	51	68
323-600-013	5084	47	6	323-600-043	2022	31	15	323-600-087	5141	51	70
323-600-013	5084	47	36	323-600-043	2022	35	3	323-600-088	5276	57	27
323-600-014	4009-1	23	3	323-600-043	2022	41	14	323-600-088	5276	57	30
323-600-014	4009-1	23	27	323-600-043	2022	41	29	323-600-090	5339	49	14
323-600-014	4009-1	25	2	323-600-043	2022	45	23	323-600-091	5359	35	12
323-600-014	4009-1	25	8	323-600-046	1170-3	35	9	323-600-097	5361	31	12
323-600-014	4009-1	27	3	323-600-047	5164	51	9	323-600-098	5357	35	56
323-600-014	4009-1	27	18	323-600-048	1333	41	27	323-600-099	5362	27	22
323-600-014	4009-1	29	2	323-600-048	1333	51	12	323-600-100	5183	57	41
323-600-014	4009-1	29	10	323-600-048	1333	61	16	323-600-101	5341	57	55
323-600-014	4009-1	33	17	323-600-050	5089	51	36	323-600-101	5341	61	69
323-600-014	4009-1	35	52	323-600-050	5089	77		323-600-102	204757	45	50
323-600-014	4009-1	43	29	323-600-051	1231	51	43	323-600-104	204496	51	20
323-600-014	4009-1	47	3	323-600-051	1231	77		323-600-107	204869	45	51
323-600-014	4009-1	49	23	323-600-054	5142	49	47	323-600-108	5371	49	45
323-600-014	4009-1	51	14	323-600-054	5142	53	22	323-600-109	5182	55	32
323-600-014	4009-1	59	47	323-600-056	2213-1	37	2	323-600-118	217	65	2
323-600-014	4009-1	61	1	323-600-056	2213-1	39	2	323-600-119	221	65	7
323-600-014	4009-1	61	28	323-600-057	5117	23	8	323-600-120	230	65	16
323-600-014	4009-1	61	40	323-600-057	5117	23	12	323-600-120	230	65	19
323-600-015	5053	27	31	323-600-057	5117	23	15	323-600-120	230	65	22
323-600-015	5053	51	51	323-600-057	5117	25	13	323-600-120	230	65	25
323-600-016	1229	47	51	323-600-057	5117	27	9	323-600-121	239	65	35
323-600-016	1229	51	25	323-600-057	5117	27	13	323-600-122	241	65	37
323-600-016	1229	57	15	323-600-057	5117	27	16	323-600-123	241	65	38
323-600-019	1175-3	33	41	323-600-057	5117	27	43	323-600-124	5366	61	25
323-600-019	1175-3	39	25	323-600-057	5117	29	15	323-600-200	1156	39	5
323-600-019	1175-3	57	33	323-600-057	5117	31	25	323-600-200	1156	41	5
323-600-019	1175-3	59	18	323-600-057	5117	49	28	323-600-202	5030	51	24
323-600-020	1170-1	39	3	323-600-057	5117	53		323-600-202	5030	51	41
323-600-020	1170-1	41	3	323-600-057	5117	53	20	323-600-202	5030	77	
323-600-020	1170-1	57	36	323-600-057	5117	57	21	323-600-206	5147	25	29
323-600-021	1206	33	29	323-600-057	5117	57	23	323-600-206	5147	29	32
323-600-021	1206	33	32	323-600-057	5117	59	5	323-600-209	5214	31	39
323-600-021	1206	33	35	323-600-057	5117	61	18	323-600-209	5214	51	3
323-600-022	2022-4	35	2	323-600-059	3001	47	23	323-600-209	5214	51	4
323-600-022	2022-4	37	7	323-600-059	3001	53	25	323-600-215	2133-1	45	25
323-600-022	2022-4	39	11	323-600-060	5118	45	40	323-600-215	2133-1	47	40
323-600-022	2022-4	41	8	323-600-060	5118	45	44	323-600-215	2133-1	51	46
323-600-022	2022-4	51	48	323-600-060	5118	51	7	323-600-217	5017	63	37
323-600-025	5064	57	6	323-600-060	5118	51	64	323-600-224	9070-2	35	16
323-600-026	2921	37	51	323-600-060	5118	57	44	323-600-225	5286	37	23
323-600-026	2921	51	30	323-600-060	5118	63	41	323-600-226	1170	49	44
323-600-026	2921	51	39	323-600-061	5152	59	44	323-600-226	1170	57	24
323-600-026	2921	51	73	323-600-062	201323	55	4	323-600-228	5061	33	19
323-600-026	2921	55	12	323-600-064	201758	55	7	323-600-229	2922	29	4
323-600-026	2921	59	39	323-600-068	1216	23	21	323-600-229	2922	43	9
323-600-027	1174	31	17	323-600-068	1216	25	23	323-600-229	2922	47	
323-600-027	1174	33	37	323-600-068	1216	27	35	323-600-229	2922	47	59
323-600-027	1174	61	41	323-600-068	1216	29	26	323-600-237	2213	57	9
323-600-029	1196	45	15	323-600-068	1216	37	11	323-600-239	2308	55	38
323-600-032	1202	27	27	323-600-068	1216	45	18	323-600-245	5136	31	7
323-600-032	1202	51		323-600-068	1216	45	42	323-600-245	5136	33	39
323-600-032	1202	51	61	323-600-068	1216	55	24	323-600-251	5022	59	21
323-600-032	1202	59	3	323-600-068	1216	57	38	323-600-251	5022	61	4
323-600-034	1459	25	22	323-600-069	1435	27	23	323-600-251	5022	61	6
323-600-034	1459	27	24	323-600-069	1435	47	27	323-600-251	5022	61	21
323-600-034	1459	29	25	323-600-072	5094	23	24	323-600-251	5022	61	23
323-600-034	1459	45	19	323-600-072	5094	25	11	323-600-255	5012	33	23

CROSS NUMBER INDEX

(Index with old numbers listed numerically begins on page 91)

NEW PRODUCT CODE NO.	OLD NO.	PAGE	REF NO.	NEW PRODUCT CODE NO.	OLD NO.	PAGE	REF NO.	NEW PRODUCT CODE NO.	OLD NO.	PAGE	REF NO.
323-600-255	5012	37	56	323-600-353	5205	47	44	323-615-213	202058	57	28
323-600-256	5029	33	25	323-600-353	5205	47	45	323-615-213	202058	57	31
323-600-256	5029	47	25	323-600-354	5138B	23	4	323-615-216	202875	37	52
323-600-256	5029	51	57	323-600-354	5138B	27	5	323-615-216	202875	55	13
323-600-257	5091	35	59	323-600-354	5138B	55	25	323-615-217	204018	31	20
323-600-257	5091	55	31	323-600-355	5317	47	38	323-615-218	202757	37	10
323-600-259	2902	37	49	323-600-356	5313	21	20	323-615-219	202769	63	31
323-600-259	2902	39	35	323-600-358	5333	43	7	323-615-219	202769	63	47
323-600-271	2193	23	9	323-600-359	5332	21	3	323-615-220	202767	63	35
323-600-271	2193	27	10	323-600-359	5332	21	23	323-615-221	204023	31	27
323-600-271	2193	37	14	323-600-360	5092	55	36	323-615-227	205066	57	5
323-600-271	2193	39	14	323-600-361	5368	59	25	323-615-229	202287A	23	5
323-600-271	2193	41	19	323-600-362	5369	59	28	323-615-229	202287A	27	6
323-600-271	2193	49	39	323-600-363	5370	59	30	323-615-229	202287A	55	26
323-600-271	2193	57	18	323-600-364	5354	61	60	323-615-231	204439	47	37
323-600-271	2193	59	7	323-600-365	5378	59	50	323-615-232	204448	21	21
323-600-271	2193	59	37	323-600-366	5346	61	10	323-615-233	204520	31	11
323-600-291	5220	37	39	323-600-367	5344	61	34	323-615-233	204520	31	13
323-600-293	5240	31	18	323-600-801	5381	43	12	323-615-233	204520	43	3
323-600-294	5238	31	26	323-600-801	5381	45	6	323-616-001	201477	63	32
323-600-295	5267	31	34	323-600-801	5381	45	35	323-616-201	201477	63	48
323-600-296	5233	33	2	323-600-801	5381	47	8	323-616-200	204293	39	22
323-600-296	5233	41	2	323-600-801	5381	47	20	323-616-200	204293	41	23
323-600-296	5233	49	2	323-600-801	5381	49	6	323-617-001	225	65	11
323-600-297	5234	33	4	323-604-201	5082A	35	42	323-617-200	202286	37	15
323-600-297	5234	49	4	323-604-201	5082A	37	46	323-617-200	202286	39	6
323-600-299	5154	35	6	323-604-201	5082A	39	32	323-617-200	202286	39	15
323-600-300	5299	35	18	323-604-209	200152	55	2	323-617-200	202286	41	6
323-600-301	1189	25	17	323-604-209	200152	55	17	323-617-200	202286	43	6
323-600-301	1189	29	20	323-604-229	167072	43	23	323-617-200	202286	47	14
323-600-301	1189	39	24	323-605-003	5347	57	50	323-617-200	202286	57	13
323-600-301	1189	41	25	323-605-003	5347	61	66	323-617-200	202286	57	19
323-600-301	1189	47	55	323-605-006	5150B	55	28	323-617-204	202045	37	24
323-600-301	1189	47	61	323-605-202	204303	63	22	323-618-003	201056	43	16
323-600-302	5227	33	20	323-605-203	202766	63	33	323-618-003	201056	47	5
323-600-302	5227	33	27	323-605-204	5302	63	46	323-618-006	201117	33	12
323-600-302	5227	57	3	323-610-001	204847	55	14	323-618-007	200183	57	16
323-600-303	5185	35	46	323-613-001	201482	35	41	323-618-010	204789	39	10
323-600-304	5239	35	54	323-613-001	201482	37	45	323-618-206	204091	41	15
323-600-305	5224	43	19	323-613-001	201482	39	31	323-618-209	202868	45	48
323-600-306	5284	39	21	323-613-001	201482	43	22	323-618-210	204311	37	13
323-600-306	5284	41	22	323-615-001	201006	21	19	323-618-210	204311	39	13
323-600-307	5077	43	32	323-615-002	200098	49	35	323-618-211	204115	43	5
323-600-307	5077	51	16	323-615-002	200098	63	43	323-618-211	204115	47	17
323-600-307	5077	51	27	323-615-010	201759	55	8	323-618-211	204115	47	32
323-600-309	5231	47	16	323-615-012	201185	41	20	323-618-212	204107	47	2
323-600-309	5231	47	31	323-615-012	201185	59	33	323-618-213	204118	27	21
323-600-312	5229	49	42	323-615-012	201185	61	62	323-618-213	204118	47	22
323-600-313	5291	51	29	323-615-013	200821	49	19	323-620-001	201002	21	8
323-600-314	5232	23	23	323-615-014	200162	27	36	323-620-001	201002	21	12
323-600-314	5232	27	37	323-615-015	201191	59	11	323-620-014	204743	27	25
323-600-314	5232	51	62	323-615-017	137142	57	43	323-620-015	204746	27	29
323-600-315	5236	51	71	323-615-017	137142	57	45	323-620-016	204796	49	21
323-600-316	2913-2	51	72	323-615-017	137142	59	17	323-620-017	204630	35	57
323-600-317	202643	51	53	323-615-021	204585	57	52	323-620-024	223	65	9
323-600-321	175	63	45	323-615-021	204585	61	35	323-620-027	303043	59	26
323-600-324	5296	63	29	323-615-021	204585	61	68	323-620-028	300135	61	13
323-600-326	5145	53	2	323-615-028	224	65	10	323-620-028	300135	61	30
323-600-327	5237	21	10	323-615-029	204806	55	29	323-620-100	195	57	46
323-600-328	5163	21	11	323-615-030	303039	59	22	323-620-237	202711A	33	3
323-600-329	5179	21	18	323-615-031	200162A	23	22	323-620-237	202711A	37	3
323-600-331	204162	49	33	323-615-201	202576	23	17	323-620-237	202711A	37	25
323-600-341	5292	35	23	323-615-201	202576	27	39	323-620-237	202711A	45	2
323-600-341	5292	43	26	323-615-203	202700	63	24	323-620-238	202712A	37	8
323-600-341	5292	59	29	323-615-209	200138	21	24	323-620-239	202647A	51	58
323-600-344	5315	31	2	323-615-209	200138	55	3	323-620-240	202653	25	4
323-600-347	5316	45	37	323-615-209	200138	55	9	323-620-240	202653	29	6
323-600-350	5326	57	11	323-615-209	200138	55	19	323-620-242	204006	21	25
323-600-351	5312	45	9	323-615-211	167066	57	34	323-620-244	204146	49	3
				323-615-213	202058	55	39	323-620-245	204154	49	20

CROSS NUMBER INDEX

(Index with old numbers listed numerically begins on page 91)

NEW PRODUCT CODE NO.	OLD NO.	PAGE	REF NO.	NEW PRODUCT CODE NO.	OLD NO.	PAGE	REF NO.	NEW PRODUCT CODE NO.	OLD NO.	PAGE	REF NO.
323-620-251	204354	45	12	323-630-235	5331	51	22	323-646-005	204867	55	33
323-620-252	204128A	47	35	323-632-001	201022	31	29	323-649-001	201009	53	8
323-620-253	204519	43	2	323-632-201	204185	45	28	323-649-003	204631	35	53
323-622-004	208009	25	19	323-632-201	204185	53	15	323-651-001	300033	61	32
323-622-004	208009	29	22	323-632-203	204438	37	20	323-653-003	202081	31	3
323-625-201	204518	43	8	323-633-002	204734	31	9	323-653-004	204618	47	10
323-625-202	204159	49	27	323-633-202	204497	51	21	323-653-005	202176	35	29
323-625-203	205070	57	14	323-634-004	200555	25	20	323-653-208	204273	37	29
323-626-201	204052A	37	17	323-634-004	200555	29	23	323-653-209	204274	37	30
323-626-201	204052A	39	17	323-634-200	202522	45	27	323-655-002	201338	53	17
323-626-201	204052A	41	11	323-634-200	202522	45	38	323-655-007	204794A	21	26
323-626-201	204052A	45	31	323-634-200	202522	57	47	323-655-009	300107	61	63
323-626-202	204022	31	24	323-635-003	601012	61	50	323-655-205	204202	55	22
323-627-005	204749	27	38	323-636-006	601001	61	48	323-659-200	132	63	2
323-627-005	204749	27	42	323-636-007	601011	61	49	323-851-021	235	65	27
323-627-009	204827	27	4	323-636-008	601014	61	52	323-851-020	237	65	29
323-627-010	204828	21	22	323-636-009	601015	61	53	323-660-200	153	63	15
323-627-014	205088	21	17	323-636-010	601016	61	54	323-662-207	204251	21	6
323-627-204	202765	63	27	323-636-011	601013	61	51	323-663-001	201311	53	18
323-627-205	204004	21	16	323-636-200	200136	55	16	323-663-010	204851	23	2
323-627-205	204004	37	35	323-638-200	201436	35	31	323-663-010	204851	27	2
323-627-207	204243	25	32	323-639-018	200698	55	15	323-663-011	204711	47	47
323-627-208	202903	55	5	323-639-019	204657	33	21	323-663-205	204319	31	8
323-628-002	204871	25	40	323-639-021	303081A	61	14	323-663-206	204201	55	27
323-628-002	204871	29	39	323-639-022	303086	61	17	323-663-208	204209	23	7
323-629-200	202641	51	49	323-639-023	600005	61	55	323-663-208	204209	27	8
323-629-201	202645	51	55	323-639-024	600006	61	56	323-663-209	204211	23	11
323-630-001	3044	23	25	323-639-025	600007	61	57	323-663-209	204211	27	12
323-630-001	3044	27	44	323-639-225	201072A	25	34	323-663-211	204192	53	23
323-630-001	3044	43	4	323-639-225	201072A	25	36	323-663-213	204277	21	13
323-630-001	3044	47	28	323-639-225	201072A	29	34	323-665-001	198	57	53
323-630-001	3044	57	42	323-639-225	201072A	29	36	323-670-200	202611	35	10
323-630-001	3044	63	39	323-639-232	204193	55	1	323-671-001	201523A	31	19
323-630-001	3044	63	42	323-639-233	204194	55	6	323-671-002	204020A	31	22
323-630-003	3091	49	15	323-640-006	204756	45	49	323-671-200	204010	31	4
323-630-003	3091	57	25	323-640-007	204745	27	28	323-672-200	204084	43	10
323-630-003	3091	61	42	323-640-008	208748	27	32	323-672-200	204084	45	4
323-630-005	5181	33	8	323-640-015	208010	25	21	323-676-025	204625A	35	25
323-630-009	5099	35	7	323-640-015	208010	29	24	323-676-027	204753	45	30
323-630-010	5074	59	12	323-640-016	303042	59	27	323-676-028	204033A	33	11
323-630-013	5348	57	51	323-640-017	300042	61	38	323-676-029	204854	37	
323-630-013	5348	61	36	323-640-018	300043	61	39	323-676-038	204875	43	14
323-630-013	5348	61	67	323-640-100	196	57	48	323-676-202	202278	35	38
323-630-015	3056	43	20	323-640-203	200205	35	15	323-676-202	202278	37	42
323-630-017	204870	45	47	323-640-217	201388	51	52	323-676-202	202278	39	28
323-630-018	222	65	8	323-640-218	204135	45	26	323-676-232	204016	31	16
323-630-019	226	65	12	323-640-219	204158	49	26	323-676-233	204032	33	10
323-630-020	231	65	17	323-640-220	204178	51	65	323-676-234	204050A	37	16
323-630-020	231	65	20	323-640-224	204329	51	28	323-676-235	204054	39	16
323-630-020	231	65	23	323-640-225	205065	57	4	323-676-235	204054	47	4
323-630-020	231	65	26	323-640-226	204171B	51	23	323-676-236	204081	37	18
323-630-021	236	65	28	323-640-228	201395	51	59	323-676-236	204081	41	12
323-630-021	236	65	30	323-641-001	204822	55	11	323-676-239	204149	49	8
323-630-022	5367	59	32	323-641-201	202689	25	5	323-676-240	204165	51	45
323-630-022	5367	61	61	323-641-201	202689	29	7	323-676-241	204241	51	67
323-630-023	303079	61	11	323-642-001	201037	35	39	323-676-243	204014	31	14
323-630-024	303034	61	27	323-642-002	201068	35	44	323-676-244	202609	35	5
323-630-200	201035A	35	37	323-642-003	201086	37	43	323-676-249	204061	37	37
323-630-200	201035A	37	41	323-642-003	201086	39	29	323-676-250	204089	43	15
323-630-200	201035A	39	27	323-642-201	167077	43	21	323-676-251	204114	47	15
323-630-202	5137	25	25	323-643-001	201156	51	37	323-676-251	204114	47	30
323-630-202	5137	29	28	323-643-001	201156	77		323-676-259	202646A	51	56
323-630-202	5137	47	13	323-643-007	303077	61	8	323-676-261	204129A	47	39
323-630-202	5137	57	12	323-643-008	303033	61	26	323-676-262	204437	37	19
323-630-203	5260	49	34	323-643-209	204233	41	18	323-676-263	204627A	35	27
323-630-204	5221	63	23	323-643-212	204357	45	21	323-680-001	201139	23	18
323-630-213	3119	35	24	323-643-213	204355	45	13	323-680-001	201139	27	40
323-630-228	5297	63	30	323-643-214	204356	45	14	323-680-002	201141	51	10
323-630-228	5297	63	49	323-646-003	204681	29	3	323-680-006	204637	45	22
323-630-229	5298	63	34	323-646-004	204868	55	37	323-680-007	204754	45	32

CROSS NUMBER INDEX

(Index with old numbers listed numerically begins on page 91)

NEW PRODUCT CODE NO.	OLD NO.	PAGE	REF NO.	NEW PRODUCT CODE NO.	OLD NO.	PAGE	REF NO.	NEW PRODUCT CODE NO.	OLD NO.	PAGE	REF NO.
323-680-204	204024	31	28	323-740-017	204750	35	55	323-801-028	202596E	68	
323-680-205	204087	43	18	323-740-018	204636	33	36	323-801-028	202596E	69	
323-680-206	204092	41	16	323-740-019	204744	27	26	323-801-028	202596E	71	
323-680-207	201635	49	10	323-740-023	204783	33	18	323-801-028	202596E	71	
323-680-208	204150	49	9	323-740-032	204097A	43	28	323-801-028	202596E	72	
323-680-210	205068	57	8	323-740-034	229	65	15	323-801-029	202597E	68	
323-683-013	204638	49	17	323-740-035	219	65	4	323-801-029	202597E	69	
323-683-014	204759	49	38	323-740-036	220	65	6	323-801-029	202597E	71	
323-683-015	204830	49	46	323-740-037	204762	33	40	323-801-029	202597E	71	
323-683-016	303085	61	15	323-740-041	303046	59	34	323-801-029	202597E	72	
323-683-201	202503	51	4	323-740-042	303050	59	42	323-801-030	202554E	72	
323-683-213	204155	49	48	323-740-043	303009	59	49	323-801-030	202554E	73	
323-683-214	204189	53	24	323-740-044	300037	61	33	323-801-030	202554E	74	
323-683-217	204231A	49	16	323-740-045	300109	61	65	323-801-030	202554E	75	
323-685-003	202199	55	18	323-740-218	202610	35	8	323-801-030	202554E	76	
323-685-008	204148B	49	7	323-740-223	202768	63	28	323-801-031	202499E	72	
323-685-012	204758	49	24	323-740-228	204452	59	6	323-801-031	202499E	73	
323-685-013	227	65	13	323-740-229	204451	57	20	323-801-034	204700	82	
323-685-014	238	65	34	323-740-229	204451	59	4	323-801-035	204701	82	
323-685-016	260	65	31	323-750-002	201107	47	42	323-801-038	202616	69	
323-685-017	261	65	32	323-750-003	204810	47	41	323-801-038	202616	70	
323-685-018	262	65	33	323-750-006	233	65	21	323-801-039	202617	69	
323-685-232	202504A	51	31	323-750-202	204153	49	43	323-801-039	202617	70	
323-685-237	204157	49	22	323-750-203	204117A	47	21	323-801-040	202674	75	
323-685-240	204237	51	8	323-750-204	205069	57	10	323-801-042	204797	71	
323-685-242	204327A	51	13	323-750-205	205104	57	29	323-801-043	204910	73	
323-685-243	205103	57	32	323-750-206	204352	45	7	323-801-044	204911	73	
323-686-002	204588	47	11	323-756-003	204632	35	58	323-801-045	204913	69	
323-686-009	204626	35	30	323-758-003	204873	31	10	323-801-045	204913	70	
323-686-010	204735	45	17	323-764-001	201294	53	5	323-801-046	204914	72	
323-686-200	201437	35	32	323-764-002	201295	53	6	323-801-047	205255	72	
323-692-017	204686	21	28	323-770-002	204121	47	26	323-801-047	205255	73	
323-692-028	300044	61	58	323-774-001	201348B	63	36	323-801-047	205255	74	
323-692-224	204334	21	27	323-774-200	201349B	63	40	323-801-047	205255	75	
323-692-256	204450	25	9	323-780-002	201039	35	40	323-801-047	205255	76	
323-692-256	204450	29	11	323-780-002	201039	39	30	323-801-048	205256	73	
323-710-002	204179A	51	66	323-780-005	204648	31	36	323-801-049	205257	73	
323-713-201	204200A	55	21	323-780-006	204658	31	35	323-801-050	204935	81	
323-716-005	204841	51	38	323-787-202	204353	45	11	323-801-050	204935	82	
323-716-006	300038	61	37	323-795-001	811002	59	31	323-801-051	204936	81	
323-716-007	522001	61	44	323-800-006	201293A	53	3	323-801-051	204936	82	
323-716-208	204172	41	26	323-800-026	204646	25	41	323-801-052	204937	81	
323-716-208	204172	51	15	323-800-026	204646	29	40	323-801-052	204937	82	
323-716-209	202683	51	6	323-800-028	204714	47	50	323-801-053	204938	81	
323-716-209	202683	51	63	323-800-031	204713A	47	49	323-801-053	204938	82	
323-716-209	202683	59	35	323-800-032	204842	23	1	323-801-054	204939	81	
323-716-214	204467	47	18	323-800-032	204842	27	1	323-801-054	204939	82	
323-716-215	204102A	45	20	323-800-034	204213A	23	14	323-801-055	204940	81	
323-720-001	204591	51	69	323-800-034	204213A	27	15	323-801-055	204940	82	
323-728-004	194	57	40	323-800-036	204142B	45	43	323-801-056	204941	81	
323-728-009	208007	25	18	323-800-041	243	65	5	323-801-056	204941	82	
323-728-009	208007	29	21	323-800-215	202849	35	43	323-801-057	204942	81	
323-730-005	204628	35	4	323-800-215	202849	37	47	323-801-057	204942	82	
323-730-207	204111	47	9	323-800-215	202849	39	33	323-801-058	204943	81	
323-730-208	204292	37	1	323-800-215	202849	43	24	323-801-058	204943	82	
323-730-209	202709A	37	5	323-800-221	204203	55	23	323-801-059	204944	81	
323-730-211	204090	41	13	323-800-222	204325	23	26	323-801-059	204944	82	
323-730-214	204140A	45	36	323-800-223	202650	27	17	323-801-060	204945	81	
323-732-001	126	61	43	323-800-224	204021	31	23	323-801-060	204945	82	
323-732-001	126	63	17	323-800-235	204495	57	17	323-801-061	204946	81	
323-732-002	199	57	54	323-801-026	202542E	68		323-801-061	204946	82	
323-734-003	204742	27	20	323-801-026	202542E	69		323-801-062	205320	68	
323-734-204	204218	23	20	323-801-026	202542E	71		323-801-063	205321	68	
323-734-204	204218	27	34	323-801-026	202542E	71		323-801-064	205322	68	
323-736-002	204845	55		323-801-026	202542E	72		323-801-065	205323	68	
323-736-003	300027	61	31	323-801-027	202546E	68		323-801-066	205324	68	
323-736-004	530001	61	45	323-801-027	202546E	69		323-801-067	205325	68	
323-740-012	201485	59	9	323-801-027	202546E	71		323-801-068	205326	68	
323-740-013	201346A	63	44	323-801-027	202546E	71		323-801-069	205327	68	
323-740-016	202705A	35	11	323-801-027	202546E	72		323-801-070	202702	72	

CROSS NUMBER INDEX

(Index with old numbers listed numerically begins on page 91)

NEW PRODUCT CODE NO.	OLD NO.	PAGE	REF NO.	NEW PRODUCT CODE NO.	OLD NO.	PAGE	REF NO.	NEW PRODUCT CODE NO.	OLD NO.	PAGE	REF NO.
323-801-070	202702	75		323-801-345	205232	70		323-820-019	201230C	77	
323-801-071	202899	75		323-801-346	205233	70		323-820-021	201152E	77	
323-801-222	202618	69		323-801-354	202981	76		323-820-022	201473B	77	
323-801-222	202618	70		323-801-355	202982	74		323-820-023	204953	69	
323-801-255	204343A	78		323-801-355	202982	76		323-820-023	204953	77	
323-801-255	204343A	79		323-801-356	202983	74		323-820-024	204954	72	
323-801-256	204344A	78		323-801-356	202983	76		323-820-024	204954	73	
323-801-256	204344A	79		323-801-357	205245	74		323-820-024	204954	74	
323-801-257	204345A	78		323-801-358	204528	82		323-820-024	204954	75	
323-801-257	204345A	79		323-801-359	204529	82		323-820-024	204954	77	
323-801-258	204346A	78		323-801-360	205239	69		323-820-025	204955	72	
323-801-258	204346A	79		323-801-360	205239	71		323-820-025	204955	74	
323-801-263	204358A	78		323-801-361	205240	69		323-820-025	204955	75	
323-801-264	204359A	78		323-801-361	205240	71		323-820-025	204955	77	
323-801-264	204359A	81		323-801-362	205241	69		323-820-026	204956	68	
323-801-266	204361A	78		323-801-362	205241	71		323-820-026	204956	71	
323-801-266	204361A	81		323-801-363	205242	69		323-820-026	204956	72	
323-801-267	204362	78		323-801-363	205242	71		323-820-026	204956	77	
323-801-267	204362	79		323-801-364	205243	73		323-820-027	204915	82	
323-801-268	204363	78		323-801-364	205243	74		323-820-220	205226	70	
323-801-268	204363	79		323-801-364	205243	76		323-820-220	205226	77	
323-801-269	204364	78		323-801-365	205244	73		323-820-255	204349A	78	
323-801-269	204364	79		323-801-365	205244	74		323-820-255	204349A	79	
323-801-270	204365	78		323-802-002	204740	27	19	323-820-255	204349A	80	
323-801-270	204365	79		323-802-003	204798	27	33	323-820-257	204433A	78	
323-801-271	204366	78		323-802-210	204215	23	16	323-820-257	204433A	80	
323-801-271	204366	79		323-810-008	204663	72		323-820-257	204433A	81	
323-801-271	204366	80		323-810-008	204663	73		323-820-258	204440	78	
323-801-272	204367	78		323-810-008	204663	74		323-820-258	204440	79	
323-801-272	204367	79		323-810-008	204663	75		323-820-259	204443	78	
323-801-272	204367	80		323-810-008	204663	76		323-820-259	204443	79	
323-801-273	204368	78		323-810-009	204702	69		323-820-259	204443	80	
323-801-273	204368	79		323-810-009	204702	70		323-820-260	204167B	78	
323-801-273	204368	80		323-810-009	204702	71		323-820-260	204167B	79	
323-801-274	204369	78		323-810-010	204703	71		323-820-260	204167B	80	
323-801-274	204369	79		323-810-011	204704	68		323-820-260	204167B	81	
323-801-274	204369	80		323-810-011	204704	78		323-820-271	204454	81	
323-801-275	204294B	78		323-810-011	204704	79		323-820-271	204454	82	
323-801-275	204294B	79		323-810-011	204704	80		323-820-272	204456	81	
323-801-275	204294B	81		323-810-011	204704	81		323-820-272	204456	82	
323-801-276	204039B	78		323-810-011	204704	82		323-820-273	204458	81	
323-801-276	204039B	79		323-810-012	204705	82		323-820-273	204458	82	
323-801-276	204039B	81		323-810-215	204278	78		323-820-280	202992	70	
323-801-277	204252B	78		323-810-215	204278	79		323-820-280	202992	77	
323-801-277	204252B	79		323-810-215	204278	81		323-820-281	202993	68	
323-801-277	204252B	81		323-810-215	204278	82		323-820-281	202993	70	
323-801-278	204295B	78		323-810-217	204314A	41	24	323-820-281	202993	77	
323-801-278	204295B	79		323-810-217	204314A	78		323-820-282	202994	71	
323-801-278	204295B	81		323-810-217	204314A	79		323-820-282	202994	77	
323-801-279	204370	80		323-810-217	204314A	80		323-820-283	209995	74	
323-801-280	204371	80		323-810-217	204314A	81		323-820-283	202995	77	
323-801-281	204372	80		323-810-217	204314A	81		323-820-284	202996	74	
323-801-282	204373	80		323-810-217	204314A	82		323-820-284	202996	76	
323-801-283	204374	80		323-810-218	204062	37	38	323-820-284	202996	77	
323-801-284	204375	80		323-810-218	204062	68		323-820-285	205252	77	
323-801-285	204376	80		323-810-218	204062	69		323-820-286	202799	77	
323-801-286	204377	80		323-810-218	204062	70		323-820-287	205253	77	
323-801-287	204378	80		323-810-218	204062	72		323-820-288	205254	77	
323-801-288	204379	80		323-810-219	204431	41		323-820-289	202997	74	
323-801-289	204380	80		323-810-219	204431	78		323-820-289	202997	76	
323-801-290	204381	80		323-810-219	204431	80		323-820-289	202997	77	
323-801-310	204360A	78		323-810-219	204431	82		323-820-299	202998	72	
323-801-310	204360A	81		323-820-013	205135	77		323-820-299	202998	74	
323-801-315	202675	72		323-820-014	205136	77		323-820-299	202998	77	
323-801-315	202675	75		323-820-017	204951	69		323-830-029	204675	68	
323-801-340	205235	70		323-820-017	204951	77		323-830-029	204675	71	
323-801-341	205236	70		323-820-018	204952	69		323-830-029	204675	72	
323-801-342	205237	70		323-820-018	204952	73		323-830-029	204675	74	
323-801-343	205238	70		323-820-018	204952	76		323-830-029	204675	75	
323-801-344	205231	70		323-820-018	204952	77		323-830-029	204675	76	

CROSS NUMBER INDEX

(Index with old numbers listed numerically begins on page 91)

NEW PRODUCT CODE NO.	OLD NO.	PAGE	REF NO.	NEW PRODUCT CODE NO.	OLD NO.	PAGE	REF NO.	NEW PRODUCT CODE NO.	OLD NO.	PAGE	REF NO.
323-830-030	204692	68		323-830-259	204414	80		323-863-007	201224B	77	
323-830-030	204692	70		323-830-260	204400	80		323-863-201	201310A	77	
323-830-030	204692	72		323-830-261	204416	80		323-863-215	201396B	77	
323-830-030	204692	74		323-830-261	204416	82		323-863-216	201461A	77	
323-830-030	204692	75		323-830-262	204394	80		323-863-217	201155C	77	
323-830-030	204692	76		323-830-262	204394	81		323-866-011	204063A	37	48
323-830-031	204721	70		323-830-262	204394	82		323-866-012	204901	39	34
323-830-032	204723	69		323-830-263	204411	80		323-866-013	204902	37	50
323-830-032	204723	73		323-830-264	204397	80		323-866-014	303048	59	38
323-830-032	204723	76		323-830-267	204408	81		323-866-213	204095A	43	25
323-830-033	204676	68		323-830-267	204408	82		323-866-214	202706A	35	17
323-830-033	204676	71		323-830-291	204420	81		323-870-004	204835	49	41
323-830-033	204676	72		323-830-295	204422	81		323-870-207	202527	49	13
323-830-033	204676	74		323-830-297	204423	82		323-870-207	202527	78	
323-830-033	204676	75		323-830-314	204248B	78		323-870-207	202527	79	
323-830-033	204676	76		323-830-316	204250B	78		323-870-207	202527	80	
323-830-034	204693	70		323-843-001	204877	78		323-870-210	202295	49	36
323-830-034	204693	72		323-843-001	204877	79		323-870-210	202295	69	
323-830-034	204693	74		323-843-001	204877	80		323-870-210	202295	70	
323-830-034	204693	75		323-843-001	204877	81		323-870-210	202295	71	
323-830-034	204693	76		323-843-001	204877	82		323-870-210	202295	72	
323-830-035	204722	70		323-843-002	204878	78		323-870-210	202295	73	
323-830-036	204724	69		323-843-002	204878	79		323-870-210	202295	74	
323-830-036	204724	73		323-843-002	204878	80		323-870-210	202295	75	
323-830-036	204724	76		323-843-002	204878	81		323-870-210	202295	76	
323-830-037	204677	69		323-843-002	204878	82		323-870-211	201127	49	37
323-830-037	204677	70		323-843-003	204879	78		323-870-211	201127	68	
323-830-037	204677	71		323-843-003	204879	80		323-870-211	201127	69	
323-830-037	204677	73		323-843-003	204879	82		323-870-211	201127	70	
323-830-037	204677	74		323-850-013	201233A	59	1	323-870-211	201127	71	
323-830-037	204677	76		323-850-021	202495	35	12	323-870-211	201127	72	
323-830-042	204838	72		323-850-022	204667	59	2	323-870-211	201127	73	
323-830-042	204838	74		323-850-023	204747	27	30	323-870-211	201127	75	
323-830-051	204678	71		323-850-024	204709	47	43	323-870-211	201127	76	
323-830-051	204678	71		323-850-026	204710A	47		323-870-213	204161	49	32
323-830-051	204678	74		323-850-027	204814A	47	46	323-870-213	204161	63	18
323-830-052	204729	69		323-850-028	204896	59		323-870-214	201121A	49	12
323-830-052	204729	70		323-850-031	228	65	14	323-870-214	201121A	78	
323-830-052	204729	73		323-850-038	303040	59	23	323-870-214	201121A	79	
323-830-054	204674	68		323-850-039	303047	59	46	323-870-214	201121A	80	
323-830-054	204674	69		323-850-040	303078	61	9	323-870-214	201121A	81	
323-830-054	204674	70		323-850-041	303035	61	29	323-870-214	201121A	81	
323-830-054	204674	71		323-850-200	201074A	39	4	323-870-214	201121A	82	
323-830-054	204674	72		323-850-200	201074A	41	4	323-870-217	204152	49	40
323-830-054	204674	73		323-850-221	200041	35	14	323-873-001	201308	51	11
323-830-054	204674	74		323-850-246	204096	43	27	323-873-002	303038	59	20
323-830-054	204674	75		323-850-247	204160A	49	29	323-873-003	303074	61	3
323-830-054	204674	76		323-850-249	202642	51	50	323-873-004	303076	61	7
323-830-055	204908	68		323-850-256	204449	59		323-873-005	303031	61	20
323-830-056	204679	71		323-850-258	205091	57	37	323-873-006	303032	61	24
323-830-057	204690	68		323-851-009	204732	37	28	323-875-001	205137	57	2
323-830-057	204690	72		323-851-018	204905	37	53	323-875-200	205064	57	1
323-830-057	204690	75		323-851-019	204903	37	55	323-880-005	200	63	13
323-830-058	204691	71		323-851-212	204235	35	19	323-880-200	130A.5	63	8
323-830-058	204691	74		323-851-213	204276	33	14	323-880-208	130A.6	63	7
323-830-059	204730	69		323-851-215	204046	33	16	323-880-209	130A.7	63	6
323-830-059	204730	70		323-851-216	204045	35	45	323-880-210	130A.8	63	5
323-830-059	204730	73		323-851-217	193174	39	36	323-880-211	130A.9	563	4
323-830-060	204907	68		323-851-219	204098	43	33	323-880-214	182	63	12
323-830-061	204931	81		323-851-220	204099	43	35	323-882-201	204003	21	15
323-830-062	204932	82		323-851-222	202704	33	15	323-885-001	127	63	9
323-830-063	204933	81		323-854-200	201265B	77		323-885-002	128	63	10
323-830-064	204934	82		323-860-200	201048A	25	33	323-885-200	179	63	11
323-830-237	204125B	79		323-860-200	201048A	25	38	323-886-001	131	63	14
323-830-238	204254B	79		323-860-200	201048A	29	33	323-891-002	204649	25	39
323-830-243	204409	78		323-860-213	201048A-125	35		323-891-002	204649	29	38
323-830-244	204395	78		323-860-213	201048A-125	37		323-891-003	596002	61	47
323-830-245	204421	82		323-860-213	201048A-129	35		323-891-200	204143A	45	45
323-830-247	204410	79		323-860-213	201048A-129	37		323-891-201	204494	55	41
323-830-248	204396	79		323-860-215	204324	43	31	323-891-202	204493	55	40

CROSS NUMBER INDEX

(Index with old numbers listed numerically begins on page 91)

NEW PRODUCT CODE NO.	OLD NO.	PAGE	REF NO.	NEW PRODUCT CODE NO.	OLD NO.	PAGE	REF NO.	NEW PRODUCT CODE NO.	OLD NO.	PAGE	REF NO.
323-900-012	204593	53									
323-900-013	204736	45	8								
323-900-014	204882	57									
323-900-017	303135	59									
323-900-018	303036	59									
323-900-019	742008	59	40								
323-900-021	760009	59	48								
323-900-022	303073	61									
323-900-023	300105	61	59								
323-900-024	303138	61									
323-900-200	202478	35	36								
323-900-201	202479	35									
323-900-202	202480	37	40								
323-900-202	202480	39	26								
323-900-215	204670	57									
323-900-224	192	57									
323-902-020	204188	53	21								
323-940-205	208	65									
323-940-206	209	65									
323-940-207	214	65									
323-940-208	210	65									
323-945-002	133	63	1								
323-945-003	135A	63	3								
323-945-202	202691	63	25								
323-945-208	202693A	63	26								
323-945-213	204301C	63	21								
Parts for Eye guard											
323-505-012	204982	25	50								
323-505-012	204982	29	49								
323-561-018	204988	25									
323-561-018	204988	29									
323-561-019	204924	25	43								
323-561-019	204924	29	42								
323-600-046	1170-3	25	48								
323-600-046	1170-3	29	47								
323-600-073	2918	25	44								
323-600-073	2918	29	43								
323-600-227	5003	25	51								
323-600-227	5003	29	50								
323-615-013	200821	25	49								
323-615-013	200821	29	48								
323-615-032	204925	25	46								
323-615-032	204925	29	45								
323-630-009	5099	25	45								
323-630-009	5099	25	52								
323-630-009	5099	29	44								
323-630-009	5099	29	51								
323-728-012	204922	25	47								
323-728-012	204922	29	46								

CROSS NUMBER INDEX

(Index with new product code numbers listed numerically begins on page 83)

OLD NO.	NEW PRODUCT CODE NO.	PAGE	REF NO.	OLD NO.	NEW PRODUCT CODE NO.	PAGE	REF NO.	OLD NO.	NEW PRODUCT CODE NO.	PAGE	REF NO.
126	323-732-001	61	43	1170	323-600-226	49	44	2022	323-600-043	45	23
126	323-732-001	63	17	1170	323-600-226	57	24	2022	323-600-043	53	14
127	323-885-001	63	9	1170-1	323-600-020	39	3	2022-4	323-600-022	35	2
128	323-885-002	63	10	1170-1	323-600-020	41	3	2022-4	323-600-022	37	7
130A-5	323-880-200	63	8	1170-1	323-600-020	57	36	2022-4	323-600-022	39	11
130A-6	323-880-208	63	7	1170-3	323-600-046	35	9	2022-4	323-600-022	41	8
130A-7	323-880-209	63	6	1174	323-600-027	31	17	2022-4	323-600-022	51	48
130A-8	323-880-210	63	5	1174	323-600-027	33	37	2133-1	323-600-215	45	25
130A-9	5323-880-211	63	4	1174	323-600-027	61	41	2133-1	323-600-215	47	40
131	323-886-001	63	14	1175-2	323-600-002	37	36	2133-1	323-600-215	51	46
132	323-659-200	63	2	1175-2	323-600-002	47	53	2147	323-600-206	29	32
133	323-945-002	63	1	1175-2	323-600-002	47	57	2193	323-600-271	23	9
135A	323-945-003	63	3	1175-2	323-600-002	49	18	2193	323-600-271	27	10
153	323-660-200	63	15	1175-2	323-600-002	49	30	2193	323-600-271	37	14
175	323-600-321	63	45	1175-2	323-600-002	59	14	2193	323-600-271	39	14
179	323-885-200	63	11	1175-3	323-600-019	33	41	2193	323-600-271	41	19
182	323-880-214	63	12	1175-3	323-600-019	39	25	2193	323-600-271	49	39
192	323-900-224	57		1175-3	323-600-019	57	33	2193	323-600-271	57	18
193	323-530-100	57	39	1175-3	323-600-019	59	18	2193	323-600-271	59	7
194	323-728-004	57	40	1189	323-600-301	25	17	2193	323-600-271	59	37
195	323-620-100	57	46	1189	323-600-301	29	20	2213	323-600-237	57	9
196	323-640-100	57	48	1189	323-600-301	39	24	2213-1	323-600-056	37	2
197	323-505-100	57	49	1189	323-600-301	41	25	2213-1	323-600-056	39	2
198	323-665-001	57	53	1189	323-600-301	47	55	2308	323-600-239	55	38
199	323-732-002	57	54	1189	323-600-301	47	61	2902	323-600-259	37	49
200	323-880-005	63	13	1196	323-600-029	45	15	2902	323-600-259	39	35
208	323-940-205	65		1202	323-600-032	27	27	2905	323-600-074	37	54
209	323-940-206	65		1202	323-600-032	51		2905	323-600-074	59	16
210	323-940-208	65		1202	323-600-032	51	61	2905	323-600-074	61	12
214	323-940-207	65		1202	323-600-032	59	3	2913-2	323-600-316	51	72
216	323-535-001	65	1	1206	323-600-021	33	29	2921	323-600-026	37	51
217	323-600-118	65	2	1206	323-600-021	33	32	2921	323-600-026	51	30
218	323-535-002	65	3	1206	323-600-021	33	35	2921	323-600-026	51	39
219	323-740-035	65	4	1216	323-600-068	23	21	2921	323-600-026	51	73
220	323-740-036	65	6	1216	323-600-068	25	23	2921	323-600-026	55	12
221	323-600-119	65	7	1216	323-600-068	27	35	2921	323-600-026	59	39
222	323-630-018	65	8	1216	323-600-068	29	26	2922	323-600-229	29	4
223	323-620-024	65	9	1216	323-600-068	37	11	2922	323-600-229	43	9
224	323-615-028	65	10	1216	323-600-068	45	18	2922	323-600-229	47	59
225	323-617-001	65	11	1216	323-600-068	45	42	3001	323-600-059	47	23
226	323-630-019	65	12	1216	323-600-068	55	24	3001	323-600-059	53	25
227	323-685-013	65	13	1216	323-600-068	57	38	3044	323-630-001	23	25
228	323-850-031	65	14	1229	323-600-016	47	51	3044	323-630-001	27	44
229	323-740-034	65	15	1229	323-600-016	51	25	3044	323-630-001	43	4
230	323-600-120	65	16	1229	323-600-016	57	15	3044	323-630-001	47	28
230	323-600-120	65	19	1231	323-600-051	51	43	3044	323-630-001	57	42
230	323-600-120	65	22	1231	323-600-051	77		3044	323-630-001	63	39
230	323-600-120	65	25	1234	323-600-006	25	6	3044	323-630-001	63	42
231	323-630-020	65	17	1234	323-600-006	29	8	3056	323-630-015	43	20
231	323-630-020	65	20	1333	323-600-048	51	12	3091	323-630-003	49	15
231	323-630-020	65	23	1333	323-600-048	61	16	3091	323-630-003	57	25
231	323-630-020	65	26	1435	323-600-069	27	23	3091	323-630-003	61	12
232	323-535-003	65	18	1435	323-600-069	47	27	3119	323-630-213	35	24
233	323-750-006	65	21	1457	323-600-012	35	26	4009-1	323-600-014	23	3
234	323-590-003	65	24	1457	323-600-012	35	28	4009-1	323-600-014	23	27
235	323-851-020	65	27	1457	323-600-012	35	35	4009-1	323-600-014	25	2
236	323-630-021	65	28	1457	323-600-012	37	4	4009-1	323-600-014	25	8
236	323-630-021	65	30	1457	323-600-012	43	36	4009-1	323-600-014	27	3
237	323-851-021	65	29	1457-1	323-600-041	37	31	4009-1	323-600-014	27	18
238	323-685-014	65	34	1458	323-600-037	53	10	4009-1	323-600-014	29	2
240	323-505-009	65	36	1459	323-600-034	25	22	4009-1	323-600-014	29	10
241	323-600-122	65	37	1459	323-600-034	27	24	4009-1	323-600-014	33	17
242	323-600-123	65	38	1459	323-600-034	29	25	4009-1	323-600-014	35	52
243	323-800-041	65	5	1459	323-600-034	45	19	4009-1	323-600-014	43	29
245	323-533-005	63	16	1732	323-600-075	35	48	4009-1	323-600-014	47	3
260	323-685-016	65	31	2022	323-600-043	21	4	4009-1	323-600-014	49	23
261	323-685-017	65	32	2022	323-600-043	31	15	4009-1	323-600-014	51	14
262	323-685-018	65	33	2022	323-600-043	35	3	4009-1	323-600-014	51	32
1156	323-600-200	39	5	2022	323-600-043	41	14	4009-1	323-600-014	59	47
1156	323-600-200	41	5	2022	323-600-043	41	29	4009-1	323-600-014	61	1

CROSS NUMBER INDEX

(Index with new product code numbers listed numerically begins on page 83)

OLD NO.	NEW PRODUCT CODE NO.	PAGE	REF NO.	OLD NO.	NEW PRODUCT CODE NO.	PAGE	REF NO.	OLD NO.	NEW PRODUCT CODE NO.	PAGE	REF NO.
4009-1	323-600-014	61	28	5117	323-600-057	23	12	5237	323-600-327	21	10
4009-1	323-600-014	61	40	5117	323-600-057	23	15	5238	323-600-294	31	26
5002	323-600-011	23	24	5117	323-600-057	25	13	5239	323-600-304	35	54
5002	323-600-011	49	25	5117	323-600-057	27	9	5239	323-600-304	37	22
5010	323-600-010	31	37	5117	323-600-057	27	13	5260	323-630-203	49	34
5010	323-600-010	49	31	5117	323-600-057	27	16	5267	323-600-295	31	34
5012	323-600-255	33	23	5117	323-600-057	27	43	5276	323-600-088	57	27
5012	323-600-255	37	56	5117	323-600-057	29	15	5276	323-600-088	57	30
5017	323-600-217	63	37	5117	323-600-057	31	25	5284	323-600-306	39	21
5022	323-600-251	25	31	5117	323-600-057	49	28	5284	323-600-306	41	22
5022	323-600-251	59	21	5117	323-600-057	53	4	5286	323-600-225	37	23
5022	323-600-251	61	4	5117	323-600-057	53	20	5291	323-600-313	51	29
5022	323-600-251	61	6	5117	323-600-057	57	21	5292	323-600-341	35	23
5022	323-600-251	61	21	5117	323-600-057	57	23	5292	323-600-341	43	26
5022	323-600-251	61	23	5117	323-600-057	59	5	5292	323-600-341	59	29
5029	323-600-256	33	25	5117	323-600-057	61	18	5296	323-600-324	63	29
5029	323-600-256	47	25	5118	323-600-060	45	44	5297	323-630-228	63	30
5029	323-600-256	51	57	5118	323-600-060	51	7	5297	323-630-228	63	49
5030	323-600-202	51	24	5118	323-600-060	51	64	5298	323-630-229	63	34
5030	323-600-202	51	41	5118	323-600-060	57	44	5299	323-600-300	35	18
5030	323-600-202	77		5118	323-600-060	63	41	5302	323-605-204	63	46
5053	323-600-015	27	31	5136	323-600-245	31	7	5312	323-600-351	45	9
5053	323-600-015	51	51	5136	323-600-245	33	39	5313	323-600-356	21	20
5060	323-600-004	49	11	5137	323-630-202	25	25	5315	323-600-344	31	2
5060	323-600-004	53	12	5137	323-630-202	29	28	5316	323-600-347	45	37
5061	323-600-228	33	19	5137	323-630-202	47	13	5317	323-600-355	47	38
5064	323-600-025	57	6	5137	323-630-202	57	12	5321A	323-600-083	45	46
5077	323-600-307	43	32	5138B	323-600-354	23	4	5326	323-600-350	57	11
5077	323-600-307	51	16	5138B	323-600-354	27	5	5331	323-630-235	51	22
5077	323-600-307	51	27	5138B	323-600-354	55	25	5332	323-600-359	21	3
5078	323-600-001	21	7	5141	323-600-087	51	70	5332	323-600-359	21	23
5080	323-600-008	31	31	5142	323-600-054	49	47	5333	323-600-358	43	7
5081	323-600-009	31	32	5142	323-600-054	53	22	5339	323-600-090	49	14
5082A	323-604-201	35	42	5145	323-600-326	53	2	5341	323-600-101	57	55
5082A	323-604-201	37	46	5147	323-600-206	25	29	5341	323-600-101	61	69
5082A	323-604-201	39	32	5150B	323-605-006	55	28	5344	323-600-367	61	34
5084	323-600-013	23	19	5152	323-600-061	59	44	5346	323-600-366	61	10
5084	323-600-013	27	41	5154	323-600-299	35	6	5347	323-605-003	57	50
5084	323-600-013	33	13	5163	323-600-328	21	11	5347	323-605-003	61	66
5084	323-600-013	37	9	5164	323-600-047	51	9	5348	323-630-013	57	51
5084	323-600-013	37	26	5179	323-600-329	21	18	5348	323-630-013	61	36
5084	323-600-013	37	33	5181	323-630-005	33	8	5348	323-630-013	61	67
5084	323-600-013	41	17	5182	323-600-109	55	32	5354	323-600-364	61	60
5084	323-600-013	43	17	5183	323-600-100	57	41	5357	323-600-098	35	56
5084	323-600-013	45	3	5184	323-600-079	59	10	5359	323-600-091	35	12
5084	323-600-013	45	33	5185	323-600-303	35	46	5361	323-600-097	31	12
5084	323-600-013	47	6	5205	323-600-353	47	44	5362	323-600-099	27	22
5084	323-600-013	47	36	5205	323-600-353	47	45	5366	323-600-124	61	25
5087	323-600-040	33	7	5214	323-600-209	31	39	5367	323-630-022	59	32
5089	323-600-050	51	36	5214	323-600-209	51	3	5367	323-630-022	61	61
5089	323-600-050	77		5214	323-600-209	51	4	5368	323-600-361	59	25
5091	323-600-257	35	59	5220	323-600-291	37	39	5369	323-600-362	59	28
5091	323-600-257	55	31	5221	323-630-204	63	23	5370	323-600-363	59	30
5092	323-600-360	55	36	5224	323-600-305	43	19	5371	323-600-108	49	45
5094	323-600-072	23	24	5227	323-600-302	33	20	5378	323-600-365	59	50
5094	323-600-072	25	11	5227	323-600-302	33	27	5381	323-600-801	43	12
5094	323-600-072	25	27	5227	323-600-302	57	3	5381	323-600-801	45	6
5094	323-600-072	29	13	5229	323-600-312	49	42	5381	323-600-801	45	35
5094	323-600-072	29	27	5231	323-600-309	47	16	5381	323-600-801	47	8
5094	323-600-072	29	30	5231	323-600-309	47	31	5881	323-600-801	47	20
5094	323-600-072	53	16	5232	323-600-314	23	23	5381	323-600-801	49	6
5095	323-600-038	25	12	5232	323-600-314	27	37	9070-2	323-600-224	35	16
5095	323-600-038	29	14	5232	323-600-314	51	62	137142	323-615-017	57	43
5099	323-630-009	35	7	5232	323-600-314	59	45	137142	323-615-017	57	45
5113	323-600-039	35	33	5233	323-600-296	33	2	167066	323-615-211	57	34
5113	323-600-039	43	30	5233	323-600-296	41	2	167072	323-604-229	43	23
5113	323-600-039	43	34	5233	323-600-296	49	2	167077	323-642-201	43	21
5113	323-600-039	55	34	5234	323-600-297	33	4	193174	323-851-217	39	36
5113	323-600-039	61	46	5234	323-600-297	49	4	200041	323-850-221	35	14
5117	323-600-057	23	8	5236	323-600-315	51	71	200098	323-615-002	49	35

CROSS NUMBER INDEX

(Index with new product code numbers listed numerically begins on page 83)

OLD NO.	NEW PRODUCT CODE NO.	PAGE	REF NO.	OLD NO.	NEW PRODUCT CODE NO.	PAGE	REF NO.	OLD NO.	NEW PRODUCT CODE NO.	PAGE	REF NO.
200098	323-615-002	63	38	201156	323-643-001	77		202295	323-870-210	74	
200098	323-615-002	63	43	201185	323-615-012	41	20	202295	323-870-210	75	
200136	323-636-200	55	16	201185	323-615-012	59	33	202295	323-870-210	76	
200138	323-615-209	21	24	201185	323-615-012	61	62	202478	323-900-200	35	36
200138	323-615-209	55	3	201191	323-615-015	59	11	202479	323-900-201	35	
200138	323-615-209	55	9	201211A	323-400-001	59	15	202480	323-900-202	37	40
200138	323-615-209	55	19	201224B	323-863-007	77		202480	323-900-202	39	26
200152	323-604-209	55	2	201230C	323-820-019	77		202495	323-850-021	35	12
200152	323-604-209	55	17	201233A	323-850-013	59	1	202499E	323-801-031	72	
200162	323-615-014	23	22	201265B	323-854-200	77		202499E	323-801-031	73	
200162A	323-615-031	27	36	201293A	323-800-006	53	3	202503	323-683-201	51	4
200183	323-618-007	57	16	201294	323-764-001	53	5	202504A	323-685-232	51	31
200205	323-640-203	35	15	201295	323-764-002	53	6	202522	323-634-200	45	27
200555	323-634-004	25	20	201308	323-873-001	51	11	202522	323-634-200	45	38
200555	323-634-004	29	23	201310A	323-863-201	77		202522	323-634-200	57	47
200698	323-639-018	55	15	201311	323-663-001	53	18	202527	323-870-207	49	13
200821	323-615-013	49	19	201323	323-600-062	55	4	202527	323-870-207	78	
201002	323-620-001	21	8	201338	323-655-002	53	17	202527	323-870-207	79	
201002	323-620-001	21	12	201341	323-508-002	53	19	202527	323-870-207	80	
201006	323-615-001	21	19	201346A	323-740-013	63	44	202542E	323-801-026	68	
201009	323-649-001	53	8	201348B	323-774-001	63	36	202542E	323-801-026	69	
201022	323-632-001	31	29	201349B	323-774-200	63	40	202542E	323-801-026	71	
201035A	323-630-200	35	37	201360A	323-576-004	33	5	202542E	323-801-026	71	
201035A	323-630-200	37	41	201388	323-640-217	51	52	202542E	323-801-026	72	
201035A	323-630-200	39	27	201395	323-640-228	51	59	202546E	323-801-027	68	
201037	323-642-001	35	39	201396B	323-863-215	77		202546E	323-801-027	69	
201039	323-780-002	35	40	201436	323-638-200	35	31	202546E	323-801-027	71	
201039	323-780-002	37	44	201437	323-686-200	35	32	202546E	323-801-027	71	
201039	323-780-002	39	30	201441A	323-576-005	33	6	202546E	323-801-027	72	
201048A	323-860-200	25	33	201461A	323-863-216	77		202554E	323-801-030	72	
201048A	323-860-200	25	38	201473B	323-820-022	77		202554E	323-801-030	74	
201048A	323-860-200	29	33	201477	323-616-001	63	32	202554E	323-801-030	76	
201048A	323-860-213-125	35	35	201477	323-616-001	63	48	202576	323-615-201	23	17
201048A	323-860-213-125	37	37	201482	323-613-001	35	41	202576	323-615-201	27	39
201048A	323-860-213-129	35	35	201482	323-613-001	37	45	202596E	323-801-028	68	
201048A	323-860-213-129	37	37	201482	323-613-001	39	31	202596E	323-801-028	69	
201056	323-618-003	43	16	201482	323-613-001	43	22	202596E	323-801-028	71	
201056	323-618-003	47	5	201485	323-740-012	59	9	202596E	323-801-028	71	
201068	323-642-002	35	44	201523A	323-671-001	31	19	202596E	323-801-028	72	
201072A	323-639-225	25	34	201635	323-680-207	49	10	202597E	323-801-029	68	
201072A	323-639-225	25	36	201758	323-600-064	55	7	202597E	323-801-029	69	
201072A	323-639-225	29	34	201759	323-615-010	55	8	202597E	323-801-029	71	
201072A	323-639-225	29	36	202058	323-615-213	55	39	202597E	323-801-029	71	
201074A	323-850-200	39	4	202058	323-615-213	57	28	202597E	323-801-029	72	
201074A	323-850-200	41	4	202058	323-615-213	57	31	202607	323-576-218	35	1
201086	323-642-003	37	43	202081	323-653-003	31	3	202609	323-676-244	35	5
201086	323-642-003	39	29	202176	323-653-005	35	29	202610	323-740-218	35	8
201107	323-750-002	47	42	202199	323-685-003	55	18	202611	323-670-200	35	10
201117	323-618-006	33	12	202278	323-676-202	35	38	202615	323-510-240	35	34
201121A	323-870-214	49	12	202278	323-676-202	37	42	202616	323-801-038	69	
201121A	323-870-214	78		202278	323-676-202	39	28	202616	323-801-038	70	
201121A	323-870-214	79		202286	323-617-200	37	15	202617	323-801-039	69	
201121A	323-870-214	80		202286	323-617-200	39	6	202617	323-801-039	70	
201121A	323-870-214	81		202286	323-617-200	39	15	202618	323-801-222	69	
201121A	323-870-214	82		202286	323-617-200	41	6	202618	323-801-222	70	
201127	323-870-211	49	37	202286	323-617-200	43	6	202641	323-629-200	51	49
201127	323-870-211	68		202286	323-617-200	47	14	202642	323-850-249	51	50
201127	323-870-211	69		202286	323-617-200	57	13	202643	323-600-317	51	53
201127	323-870-211	70		202286	323-617-200	57	19	202644A	323-530-233	51	54
201127	323-870-211	71		202286	323-617-200	59	8	202645	323-629-201	51	55
201127	323-870-211	72		202287A	323-615-229	23	5	202646A	323-676-259	51	56
201127	323-870-211	73		202287A	323-615-229	27	6	202647A	323-620-239	51	58
201127	323-870-211	75		202287A	323-615-229	55	26	202650	323-800-223	27	17
201127	323-870-211	76		202295	323-870-210	49	36	202653	323-620-240	25	4
201139	323-680-001	23	18	202295	323-870-210	68		202653	323-620-240	29	6
201139	323-680-001	27	40	202295	323-870-210	69		202674	323-801-040	75	
201141	323-680-002	51	10	202295	323-870-210	70		202675	323-801-315	72	
201152E	323-820-021	77		202295	323-870-210	71		202675	323-801-315	75	
201155C	323-863-217	77		202295	323-870-210	72		202683	323-716-209	51	6
201156	323-643-001	51	37	202295	323-870-210	73		202683	323-716-209	51	63

CROSS NUMBER INDEX

(Index with new product code numbers listed numerically begins on page 83)

OLD NO.	NEW PRODUCT CODE NO.	PAGE	REF NO.	OLD NO.	NEW PRODUCT CODE NO.	PAGE	REF NO.	OLD NO.	NEW PRODUCT CODE NO.	PAGE	REF NO.
202683	323-716-209	59	35	204023	323-615-221	31	27	204111	323-730-207	47	9
202683	323-716-209	59	43	204024	323-680-204	31	28	204112	323-525-233	47	12
202689	323-641-201	25	5	204025	323-546-203	31	30	204114	323-676-251	47	15
202689	323-641-201	29	7	204026	323-546-204	31	33	204114	323-676-251	47	30
202691	323-945-202	63	25	204028	323-510-245	31	38	204115	323-618-211	43	5
202693A	323-945-208	63	26	204029	323-535-205	33	1	204115	323-618-211	47	17
202700	323-615-203	63	24	204031	323-540-232	33	9	204115	323-618-211	47	32
202702	323-801-070	72		204032	323-676-233	33	10	204116A	323-518-202	47	19
202702	323-801-070	75		204033A	323-676-028	33	11	204117A	323-750-203	47	21
202704	323-851-222	33	15	204039B	323-801-276	79		204118	323-618-213	27	21.
				204039B	323-801-276	81		204118	323-618-213	47	22
202705A	323-740-016	35	11	204042	323-561-218	78		204119A	323-510-263	47	24
202706A	323-866-214	35	17	204042	323-561-218	79		204121	323-770-002	47	26
202709A	323-730-209	37	5	204042	323-561-218	80		204122	323-525-234	47	29
202711A	323-620-237	33	3	204042	323-561-218	81		204123A	323-593-003	47	33
202711A	323-620-237	37	3	204042	323-561-218	82		204124	323-593-207	47	34
202711A	323-620-237	37	25	204045	323-851-216	35	45	204125B	323-830-237	79	
202711A	323-620-237	45	2	204046	323-851-215	33	16	204128A	323-620-252	47	35
202712A	323-620-238	37	8	204047	323-525-230	39	1	204129A	323-676-261	47	39
202757	323-615-218	37	10	204048A	323-576-213	39	9	204134A	323-535-212	45	24
202765	323-627-204	63	27								
				204050A	323-676-234	37	16	204135	323-640-218	45	26
202767	323-615-220	63	35	204052A	323-626-201	37	17	204139A	323-502-213	45	34
202768	323-740-223	63	28	204052A	323-626-201	39	17	204140A	323-730-214	45	36
202769	323-615-219	63	31	204052A	323-626-201	41	11	204142B	323-800-036	45	43
202769	323-615-219	63	47	204052A	323-626-201	45	31	204143A	323-891-200	45	45
202799	323-820-286	77		204054	323-676-235	39	16	204145	323-525-235	49	1
202849	323-800-215	35	43	204054	323-676-235	47	4	204146	323-620-244	49	3
202849	323-800-215	37	47	204055A	323-525-229	37	21	204147	323-525-236	49	5
202849	323-800-215	39	33	204057A	323-530-224	37	27	204148B	323-685-008	49	7
202849	323-800-215	43	24	204059	323-676-248	37	32	204149	323-676-239	49	8
202868	323-618-209	45	48								
				204060	323-515-202	37	34	204150	323-680-208	49	9
202875	323-615-216	37	52	204061	323-676-249	37	37	204152	323-870-217	49	40
202875	323-615-216	55	13	204062	323-810-218	37	38	204153	323-750-202	49	43
202899	323-801-071	75		204062	323-810-218	68		204154	323-620-245	49	20
202903	323-627-208	55	5	204062	323-810-218	69		204155	323-683-213	49	48
202981	323-801-354	76		204062	323-810-218	70		204156	323-560-225	49	49
202982	323-801-355	74		204062	323-810-218	72		204157	323-685-237	49	22
202982	323-801-355	76		204063A	323-866-011	37	48	204158	323-640-219	49	26
202983	323-801-356	74		204069A	323-540-228	37	12	204159	323-625-202	49	27
202983	323-801-356	76		204069A	323-540-228	39	12	204160A	323-850-247	49	29
202992	323-820-280	70									
				204071	323-530-225	39	18	204161	323-870-213	49	32
202992	323-820-280	77		204075	323-525-231	41	1	204161	323-870-213	63	18
202993	323-820-281	68		204076	323-576-219	41	7	204162	323-600-331	49	33
202993	323-820-281	70		204077	323-580-208	41	28	204163A	323-502-209	51	1
202993	323-820-281	77		204078	323-540-233	41		204164	323-540-240	51	44
202994	323-820-282	71		204078	323-540-233	45		204165	323-676-240	51	45
202994	323-820-282	77		204079	323-540-225	41	9	204166	323-530-229	51	47
202995	323-820-283	76		204080	323-540-234	41	10	204167B	323-820-260	78	
202995	323-820-283	77		204081	323-676-236	37	18	204167B	323-820-260	79	
202996	323-820-284	74		204081	323-676-236	41	12	204167B	323-820-260	80	
202996	323-820-284	76									
				204082A	323-525-239	43	1	204167B	323-820-260	81	
202996	323-820-284	77		204084	323-672-200	43	10	204171B	323-640-226	51	23
202997	323-820-289	74		204084	323-672-200	45	4	204172	323-716-208	41	26
202997	323-820-289	76		204085	323-576-220	45	5	204172	323-716-208	51	15
202997	323-820-289	77		204086B	323-580-210	45	16	204173A	323-560-221	78	
202998	323-820-299	72		204087	323-680-205	43	18	204173A	323-560-221	79	
202998	323-820-299	74		204089	323-676-250	43	15	204173A	323-560-221	80	
202998	323-820-299	77		204090	323-730-211	41	13	204177B	323-530-016	51	60
204000B	323-508-007	21	1	204091	323-618-206	41	15	204178	323-640-220	51	65
204003	323-882-201	21	15	204092	323-680-206	41	16	204179A	323-710-002	51	66
204004	323-627-205	21	16								
				204093	323-530-226	41	21	204180	323-515-203	53	1
204004	323-627-205	37	35	204095A	323-866-213	43	25	204183	323-540-237	53	7
204006	323-620-242	21	25	204096	323-850-246	43	27	204184	323-540-236	53	9
204010	323-671-200	31	4	204097A	323-740-032	43	28	204185	323-632-201	45	28
204014	323-676-243	31	14	204098	323-851-219	43	33	204185	323-632-201	53	15
204016	323-676-232	31	16	204099	323-851-220	43	35	204186	323-570-203	53	13
204018	323-615-217	31	20	204100	323-525-232	45	1	204187	323-570-204	53	11
204019A	323-646-001	31	21	204101A	323-580-211	45	10	204188	323-902-020	53	21
204020A	323-671-002	31	22	204107	323-618-212	47	2	204189	323-683-214	53	24
204021	323-800-224	31	23	204110A	323-576-215	47	7	204192	323-663-211	53	23
204022	323-626-202	31	24								

CROSS NUMBER INDEX

(Index with new product code numbers listed numerically begins on page 83)

OLD NO.	NEW PRODUCT CODE NO.	PAGE	REF NO.	OLD NO.	NEW PRODUCT CODE NO.	PAGE	REF NO.	OLD NO.	NEW PRODUCT CODE NO.	PAGE	REF NO.
204193	323-639-232	55	1	204327A	323-685-242	51	13	204410	323-830-247	79	
204194	323-639-233	55	6	204329	323-640-224	51	28	204411	323-830-263	80	
204198	323-568-202	55	20	204332	323-576-217	37	6	204414	323-830-259	80	
204200A	323-713-201	55	21	204334	323-692-224	21	27	204416	323-830-261	80	
204201	323-663-206	55	27	204343A	323-801-255	78		204416	323-830-261	82	
204202	323-655-205	55	22	204343A	323-801-255	79		204420	323-830-291	81	
204203	323-800-221	55	23	204344A	323-801-256	78		204421	323-830-245	82	
204208	323-510-247	23	6	204344A	323-801-256	79		204422	323-830-295	81	
204208	323-510-247	27	7	204345A	323-801-257	78		204423	323-830-297	82	
204209	323-663-208	23	7	204345A	323-801-257	79		204431	323-810-219	41	
204209	323-663-208	27	8	204346A	323-801-258	78		204431	323-810-219	78	
204210A	323-510-265	23	10	204346A	323-801-258	79		204431	323-810-219	80	
204210A	323-510-265	27	11	204349A	323-820-255	78		204431	323-810-219	81	
204211	323-663-209	23	11	204349A	323-820-255	79		204431	323-810-219	82	
204211	323-663-209	27	12	204349A	323-820-255	80		204433A	323-820-257	78	
204212A	323-510-237	23	13	204352	323-750-206	45	7	204433A	323-820-257	80	
204212A	323-510-237	27	14	204353	323-787-202	45	11	204433A	323-820-257	81	
204213A	323-800-034	23	14	204354	323-620-251	45	12	204437	323-676-262	37	19
204213A	323-800-034	27	15	204355	323-643-213	45	13	204438	323-632-203	37	20
204215	323-802-210	23	16	204356	323-643-214	45	14	204439	323-615-231	47	37
204218	323-734-204	23	20	204357	323-643-212	45	21	204440	323-820-258	78	
204218	323-734-204	27	34	204358A	323-801-263	78		204440	323-820-258	79	
204223	323-510-248	25	7	204358A	323-801-263	81		204443	323-820-259	78	
204223	323-510-248	29	9	204359A	323-801-264	78		204443	323-820-259	79	
204224	323-510-251	25	10	204359A	323-801-264	81		204447	323-560-234	78	
204224	323-510-251	29	12	294360A	323-801-310	78		204447	323-560-234	79	
204231A	323-683-217	49	16	204360A	323-801-310	81		204447	323-560-234	80	
204233	323-643-209	41	18	204361A	323-801-266	78		204448	323-615-232	21	21
204235	323-851-212	35	19	204361A	323-801-266	81		204449	323-850-256	59	
204237	323-685-240	51	8	204362	323-801-267	78		204450	323-692-256	25	9
204241	323-676-241	51	67	204362	323-801-267	79		204450	323-692-256	29	11
204242	323-627-206	25	30	204363	323-801-268	78		204451	323-740-229	57	20
304243	323-627-207	25	32	204363	323-801-268	79		204451	323-740-229	59	4
204248B	323-830-314	78		204364	323-801-269	78		204452	323-740-228	59	6
204250B	323-830-316	78		204364	323-801-269	79		204454	323-820-271	81	
204251	323-662-207	21	6	204365	323-801-270	79		204454	323-820-271	82	
204252B	323-801-277	78		204366	323-801-271	78		204456	323-820-272	81	
204252B	323-801-277	79		204366	323-801-271	79		204456	323-820-272	82	
204252B	323-801-277	81		204366	323-801-271	80		204458	323-820-273	81	
204254B	323-830-238	79		204367	323-801-272	78		204458	323-820-273	82	
204273	323-653-208	37	29	204367	323-801-272	79		204460	323-560-235	81	
204274	323-653-209	37	30	204367	323-801-272	80		204460	323-560-235	82	
204276	323-851-213	33	14	204368	323-801-273	78		204467	323-716-214	47	18
204277	323-663-213	21	13	204368	323-801-273	79		204493	323-891-202	55	40
204278	323-810-215	78		204368	323-801-273	80		204494	323-891-201	55	41
204278	323-810-215	79		204369	323-801-274	78		204495	323-800-235	57	17
204278	323-810-215	82		204369	323-801-274	79		204496	323-600-104	51	20
204292	323-730-208	37	1	204369	323-801-274	80		204497	323-633-202	51	21
204293	323-616-200	39	22	204370	323-801-279	80		204517	323-576-225	43	11
204293	323-616-200	41	23	204371	323-801-280	80		204518	323-625-201	43	8
204294B	323-801-275	78		204372	323-801-281	80		204519	323-620-253	43	2
204294B	323-801-275	79		204373	323-801-282	80		204520	323-615-233	31	11
204294B	323-801-275	81		204374	323-801-283	80		204520	323-615-233	31	13
204295B	323-801-278	78		204375	323-801-284	80		204520	323-615-233	43	3
204295B	323-801-278	79		204376	323-801-285	80		204521	323-561-219	78	
204295B	323-801-278	81		204377	323-801-286	80		204521	323-561-219	79	
204301C	323-945-213	63	21	204378	323-801-287	80		204521	323-561-219	80	
204303	323-605-202	63	22	204379	323-801-288	80		204521	323-561-219	81	
204311	323-618-210	37	13	204380	323-801-289	80		204521	323-561-219	82	
204311	323-618-210	39	13	204381	323-801-290	80		204522	323-561-220	78	
204314A	323-810-217	41	24	204394	323-830-262	80		204522	323-561-220	79	
204314A	323-810-217	78		204394	323-830-262	81		204522	323-561-220	80	
204314A	323-810-217	79		204394	323-830-262	82		204522	323-561-220	81	
204314A	323-810-217	80		204395	323-830-244	78		204522	323-561-220	82	
204314A	323-810-217	81		204396	323-830-248	79		204528	323-801-358	82	
204314A	323-810-217	81		204397	323-830-264	80		204529	323-801-359	82	
204314A	323-810-217	82		204400	323-830-260	80		204536	323-561-211	78	
204319	323-663-205	31	8	204408	323-830-267	81		204536	323-561-211	79	
204324	323-860-215	43	31	204408	323-830-267	82		204536	323-561-211	80	
204325	323-800-222	23	26	204409	323-830-243	78		204536	323-561-211	81	

CROSS NUMBER INDEX

(Index with new product code numbers listed numerically begins on page 83)

OLD NO.	NEW PRODUCT CODE NO.	PAGE	REF NO.	OLD NO.	NEW PRODUCT CODE NO.	PAGE	REF NO.	OLD NO.	NEW PRODUCT CODE NO.	PAGE	REF NO.
204536	323-561-211	82		204674	323-830-054	69		204724	323-830-036	69	
204585	323-615-021	57	52	204674	323-830-054	70		204724	323-830-036	73	
204585	323-615-021	61	35	294674	323-830-054	72		204724	323-830-036	76	
204585	323-615-021	61	68	204674	323-830-054	73		204729	323-830-052	69	
204588	323-686-002	47	11	204674	323-830-054	74		204729	323-830-052	70	
204590	323-600-084	51	68	204674	323-830-054	75		204729	323-830-052	73	
204591	323-720-001	51	69	204674	323-830-054	76		204730	323-830-059	69	
204592	323-534-001	57	26	204675	323-830-029	68		204730	323-830-059	70	
204593	323-900-012	53		204675	323-830-029	71		204730	323-830-059	73	
204618	323-653-004	47	10	204675	323-830-029	72		204731	323-801-041	71	
204622A	323-500-006	21	5	204675	323-830-029	74		204732	323-851-009	37	28
204623	323-591-003	68		204675	323-830-029	75		204733	323-540-015	31	1
204623	323-591-003	69		204675	323-830-029	76		204734	323-633-002	31	9
204623	323-591-003	71		204676	323-830-033	68		204735	323-686-010	45	17
204623	323-591-003	72		204676	323-830-033	71		204736	323-900-013	45	8
204624	323-591-004	72		204676	323-830-033	72		203737	323-515-002	31	6
204624	323-591-004	73		204676	323-830-033	74		204739	323-508-004	21	2
204624	323-591-004	74		204676	323-830-033	75		204740	323-802-002	27	19
204624	323-591-004	75		204676	323-830-033	76		204742	323-734-003	27	20
204624	323-591-004	76		204677	323-830-037	69		204743	323-620-014	27	25
204625A	323-676-025	35	25	204677	323-830-037	70		204744	323-740-019	27	26
204626	323-686-009	35	30	204677	323-830-037	71		204745	323-640-007	27	28
204627A	323-676-263	35	27	204677	323-830-037	73		204746	323-620-015	27	29
204628	323-730-005	35	4	204677	323-830-037	74		204747	323-850-023	27	30
204630	323-620-017	35	57	204677	323-830-037	76		204748	323-640-008	27	32
204631	323-649-003	35	53	204678	323-830-051	71		204749	323-627-005	27	38
204632	323-756-003	35	58	204678	323-830-051	71		204749	323-627-005	27	42
204634	323-561-009	68		204678	323-830-051	74		204750	323-740-017	35	55
204634	323-561-009	69		204679	323-830-056	71		204751	323-540-016	47	1
204634	323-561-009	70		204681	323-646-003	29	3	204752	323-540-017	45	29
204634	323-561-009	71		204683	323-560-029	82		204753	323-676-027	45	30
204634	323-561-009	72		204686	323-692-017	21	28	204754	323-680-007	45	32
204635	323-561-010	68		204690	323-830-057	68		204755	323-530-011	45	39
204535	323-561-010	69		204690	323-830-057	72		204756	323-640-006	45	49
204635	323-561-010	70		204690	323-830-057	75		204757	323-600-102	45	50
204635	323-561-010	71		204691	323-830-058	71		204758	323-685-012	49	24
204635	323-561-010	72		204691	323-830-058	74		204759	323-683-014	49	38
204636	323-740-018	33	36	204692	323-830-030	68		204760	323-505-010	59	13
204637	323-680-006	45	22	204692	323-830-030	72		204762	323-740-037	33	40
204638	323-683-013	49	17	204692	323-830-030	74		204781	323-561-013	33	22
204640A	323-502-007	51	2	204692	323-830-030	75		204782	323-561-014	33	24
204646	323-800-026	25	41	204692	323-830-030	76		204783	323-740-023	33	18
204646	323-800-026	29	40	204693	323-830-034	70		204787	323-576-006	39	7
204648	323-780-005	31	36	204693	323-830-034	72		204788	323-576-007	39	8
204649	323-891-002	25	39	204693	323-830-034	74		204789	323-618-010	39	10
204649	323-891-002	29	38	204693	323-830-034	75		204794A	323-655-007	21	26
204650A	323-510-030	25	26	204693	323-830-034	76		204796	323-620-016	49	21
204650A	323-510-030	29	29	204700	323-801-034	82		204797	323-801-042	71	1
204657	323-639-019	33	21	204701	323-801-035	82		204798	323-802-003	27	33
204658	323-780-006	31	35	204702	323-810-009	69		204799	323-560-014	25	28
204659	323-561-011	72		204702	323-810-009	70		204806	323-615-029	55	29
204659	323-561-011	73		204702	323-810-009	71		204810	323-750-003	47	41
204659	323-561-011	74		204703	323-810-010	71		204814A	323-850-027	47	46
204659	323-561-011	75		204704	323-810-011	68		204822	323-641-001	55	11
204659	323-561-011	76		204704	323-810-011	78		204827	323-627-009	27	4
204660	323-561-012	72		204704	323-810-011	79		204828	323-627-010	21	22
204660	323-561-012	73		204704	323-810-011	80		204830	323-683-015	49	46
204660	323-561-012	74		204704	323-810-011	81		204835	323-870-004	49	41
294660	323-561-012	75		204704	323-810-011	82		204837	323-591-006	72	
204660	323-561-012	76		204705	323-810-012	82		204837	323-591-006	74	
204663	323-810-008	72		204709	323-850-024	47	43	204838	323-830-042	72	
204663	323-810-008	73		204711	323-663-011	47	47	204838	323-830-042	74	
204663	323-810-008	74		204712	323-560-012	47	48	204841	323-716-005	51	38
204663	323-810-008	75		204713A	323-800-031	47	49	204842	323-800-032	23	1
204663	323-810-008	76		204714	323-800-028	47	50	204842	323-800-032	27	1
204664	323-530-010	39	19	204721	323-830-031	70		204845	323-736-002	55	
204667	323-850-022	59	2	204722	323-830-035	70		204847	323-610-001	55	14
204668	323-560-020	77		204723	323-830-032	69		294848	323-560-016	25	1
204670	323-900-215	57		204723	323-830-032	73		204848	323-560-016	29	1
204674	323-830-054	68		204723	323-830-032	76		204849	323-560-015	21	14

CROSS NUMBER INDEX

(Index with new product code numbers listed numerically begins on page 83)

OLD NO.	NEW PRODUCT CODE NO.	PAGE	REF NO.	OLD NO.	NEW PRODUCT CODE NO.	PAGE	REF NO.	OLD NO.	NEW PRODUCT CODE NO.	PAGE	REF NO.
204850	323-500-004	21	9	204943	323-801-058	81		205255	323-801-047	72	
204851	323-663-010	23	2	204943	323-801-058	82		205255	323-801-047	73	
204851	323-663-010	27	2	204944	323-801-059	81		205255	323-801-047	74	
204853	323-530-017	39	20	204944	323-801-059	82		205255	323-801-047	75	
204854	323-676-029	37		204945	323-801-060	81		205255	323-801-047	76	
204857	323-510-031	55	35	204945	323-801-060	82		205256	323-801-048	73	
204865	323-510-032	55	30	204946	323-801-061	81		205257	323-801-049	73	
204867	323-646-005	55	33	204946	323-801-061	82		205320	323-801-062	68	
204868	323-646-004	55	37	204951	323-820-017	69		205321	323-801-063	68	
204869	323-600-107	45	51	204951	323-820-017	77		205322	323-801-064	68	
204870	323-630-017	45	47	204952	323-820-018	69		205323	323-801-065	68	
204871	323-628-002	25	40	204952	323-820-018	73		205324	323-801-066	68	
204871	323-628-002	29	39	204952	323-820-018	76		205325	323-801-067	68	
204872	323-591-007	73		204952	323-820-018	77		205326	323-801-068	68	
204872	323-591-007	75		204953	323-820-023	69		205327	323-801-069	68	
204872	323-591-007	76		204953	323-820-023	77		205342	323-560-021	77	
204873	323-758-003	31	10	204954	323-820-024	72		205554E	323-801-030	73	
204874	323-540-024	43	13	204954	323-820-024	73		208000	323-510-052	29	16
204875	323-676-038	43	14	204954	323-820-024	74		208002	323-510-050	25	15
204877	323-843-001	78		204954	323-820-024	75		208003	323-510-046	29	17
204877	323-843-001	79		204954	323-820-024	77		208005	323-510-048	29	19
204877	323-843-001	80		204955	323-820-025	72		208007	323-728-009	25	18
204877	323-843-001	81		204955	323-820-025	74		208007	323-728-009	29	21
204877	323-843-001	82		204955	323-820-025	75		208009	323-622-004	25	19
204878	323-843-002	78		204955	323-820-025	77		208009	323-622-004	29	22
204878	323-843-002	79		204956	323-820-026	68		208010	323-640-015	25	21
204878	323-843-002	80		204956	323-820-026	71		208010	323-640-015	29	24
204878	323-843-002	81		204956	323-820-026	72		208012	323-510-054	25	14
204878	323-843-002	82		205064	323-875-200	57	1	208023	323-510-051	25	3
204879	323-843-003	78		205065	323-640-225	57	4	208023	323-510-051	29	5
204879	323-843-003	80		205066	323-615-227	57	5	208058	323-510-053	29	18
204879	323-843-003	81		205067	323-540-246	57	7	209995	323-820-283	74	
204879	323-843-003	82		205068	323-680-210	57	8	300027	323-736-003	61	31
204881	323-515-004	31	5	205069	323-750-204	57	10	300033	323-651-001	61	32
204882	323-900-014	57		205070	323-625-203	57	14	300037	323-740-044	61	33
204883	323-530-018	45	41	205072	323-530-232	57	22	300038	323-716-006	61	37
204884	323-561-017	33	38	205088	323-627-014	21	17	300042	323-640-017	61	38
204896	323-850-028	59		205091	323-850-258	57	37	300043	323-640-018	61	39
204901	323-866-012	39	34	205103	323-685-243	57	32	300044	323-692-028	61	58
204903	323-851-019	37	55	205104	323-750-205	57	29	300105	323-900-023	61	59
204905	323-851-018	37	53	205135	323-820-013	77		300107	323-655-009	61	63
204907	323-830-060	68		205136	323-820-014	77		300108	323-634-005	61	64
204908	323-830-055	68		205137	323-875-001	57	2	300109	323-740-045	61	65
204909	323-830-053	68		205226	323-820-220	70		300135	323-620-028	61	13
204910	323-801-043	73		205226	323-820-220	77		300135	323-620-028	61	30
204911	323-801-044	73		205231	323-801-344	70		303009	323-740-043	59	49
204913	323-801-045	69		205232	323-801-345	70		303030	323-508-009	61	19
204913	323-801-045	70		205233	323-801-346	70		303031	323-873-005	61	20
204914	323-801-046	72		205234	323-801-347	70		303032	323-873-006	61	24
204915	323-820-027	82		205235	323-801-340	70		303033	323-643-008	61	26
204931	323-830-061	81		205236	323-801-341	70		303034	323-630-024	61	27
204932	323-830-062	82		205237	323-801-342	70		303035	323-850-041	61	29
204933	323-830-063	81		205238	323-801-343	70		303136	323-900-018	59	
204934	323-830-064	82		205239	323-801-360	69		303036	323-560-028	61	22
204935	323-801-050	81		205239	323-801-360	71		303037	323-505-011	59	19
204935	323-801-050	82		205240	323-801-361	69		303038	323-873-002	59	20
204936	323-801-051	81		205240	323-801-361	71		303039	323-615-030	59	22
204936	323-801-051	82		205241	323-801-362	69		303040	323-850-038	59	23
204937	323-801-052	81		205241	323-801-362	71		303041	323-530-021	59	24
204937	323-801-052	82		205242	323-801-363	69		303042	323-640-016	59	27
204938	323-801-053	81		205242	323-801-363	71		303043	323-620-027	59	26
204938	323-801-053	82		205243	323-801-364	73		303046	323-740-041	59	34
204939	323-801-054	81		205243	323-801-364	74		303047	323-850-039	59	46
204939	323-801-054	82		205243	323-801-364	76		303048	323-866-014	59	38
204940	323-801-055	81		205244	323-801-365	73		303049	323-530-022	59	36
204940	323-801-055	82		205244	323-801-365	74		303050	323-740-042	59	42
204941	323-801-056	81		205245	323-801-357	74		303073	323-900-022	61	
204941	323-801-056	82		205252	323-820-285	77		303074	323-873-003	61	3
204942	323-801-057	81		205253	323-820-287	77		303075	323-560-027	61	5
204942	323-801-057	82		205254	323-820-288	77		303076	323-873-004	61	7

CROSS NUMBER INDEX

(Index with new product code numbers listed numerically begins on page 83)

<u>OLD NO.</u>	<u>NEW PRODUCT CODE NO.</u>	<u>PAGE</u>	<u>REF NO.</u>	<u>OLD NO.</u>	<u>NEW PRODUCT CODE NO.</u>	<u>PAGE</u>	<u>REF NO.</u>	<u>OLD NO.</u>	<u>NEW PRODUCT CODE NO.</u>	<u>PAGE</u>	<u>REF NO.</u>
303077	323-643-007	61	8								
303078	323-850-040	61	9								
303079	323-630-023	61	11								
303080	323-508-008	61	2								
303081A	323-639-021	61	14								
303085	323-683-016	61	15								
303135	323-900-017	59									
303138	323-900-024	61									
304692	323-830-030	70									
522001	323-716-007	61	44								
530001	323-736-004	61	45								
596002	323-891-003	61	47								
600005	323-639-023	61	55								
600006	323-639-024	61	56								
600007	323-639-025	61	57								
601001	323-636-006	61	48								
601011	323-636-007	61	49								
601012	323-635-003	61	50								
601013	323-636-011	61	51								
601014	323-636-008	61	52								
601015	323-636-009	61	53								
601016	323-636-010	61	54								
706001	323-900-020	59	41								
742008	323-900-019	59	40								
760009	323-900-021	59	48								
811002	323-795-001	59	31								
Parts for Eye guard											
1170-3323-600-046		25	48								
1170-3323-600-046		29	47								
2918	323-600-073	25	44								
2918	323-600-073	29	43								
5003	323-600-227	25	51								
5003	323-600-227	29	50								
5099	323-630-009	25	45								
5099	323-630-009	25	52								
5099	323-630-009	29	44								
5099	323-630-009	29	51								
200821	323-615-013	25	49								
200821	323-615-013	29	48								
204922	323-728-012	25	47								
204922	323-728-012	29	46								
204924	323-561-019	25	43								
204924	323-561-019	29	42								
204925	323-615-032	25	46								
204925	323-615-032	29	45								
204982	323-505-012	25	50								
204982	323-505-012	29	49								
204988	323-561-018	25									
204988	323-561-018	29									

SEWING ORGANIZATIONS FOR 500/IV LINE

TYPE NO.	NO. OF THRDS.	FEDERAL STITCH	FEED DESIGN	FEED RATIO	OPERATION AND FABRIC
503/IV-44	2	503	2 row wide - medium	1.5:1	serging woven fabric
503/IV-48	2	503	3 row long - medium	1.5:1	serging woven fabric
504/IV-7	3	504	3 row long - medium	2:1	seaming woven & knits
504/IV-17	3	504	3 row long - medium	3:1	shirring-intermittent
504/IV-19	3	504	2 row narrow-medium	2:1	seaming light knits
504/IV-21	3	504	3 row long - medium	3:1	shirring-intermittent
504/IV-25	3	505	2 row narrow-medium	2:1	hemming light knits
504/IV-43	3	504	3 row short -medium	2:1	seaming light knits
504/IV-45	3	504	2 row wide - medium	2:1	seaming medium-heavy knits
504/IV-47	3	504	3 row long - medium	2:1	seaming woven and knits
504/IV-S-10	3	504	3 row long - coarse	2:1	seaming jeans
504/IV-S-16	3	504	3 row long - coarse	3:1	seaming bulky knitwear
504/IV-S-17	3	504	3 row long - medium	3:1	seaming knits
504/IV-S-45	3	504	2 row wide - medium	3:1	seaming sweaters
504/IV-S-47	3	504	3 row long - medium	3:1	seaming sweaters
514/IV-11	4	512	3 row long - medium	2:1	2 needle seaming woven fabrics
514/IV-12	4	512	2 row wide - medium	2:1	2 needle seaming woven fabrics
514/IV-20	4	514	2 row narrow-medium	2:1	2 needle seaming light knits
514/IV-22	4	512	3 row long - medium	3:1	2 needle shirring-intermittent
514/IV-23	4	512	3 row long - medium	3:1	2 needle shirring-intermittent
514/IV-41	4	512	3 row long - medium	2:1	2 needle seaming
514/IV-42	4	512	2 row wide - medium	2:1	2 needle seaming
514/IV-S-11	4	514	3 row long - coarse	3:1	2 needle seaming bulky knits
514/IV-S-13	4	514	2 row wide - medium	2:1	2 needle seaming light knits
514/IV-S-14	4	514	3 row long - medium	3:1	2 needle seaming knits
514/IV-S-15	4	514	3 row long - medium	2:1	2 needle seaming knits
514/IV-S-18	4	514	3 row long - medium	3:1	2 needle shirring-intermittent
514/IV-S-19	4	514	3 row long - medium	2:1	2 needle seaming
514/IV-S-20	4	514	2 row wide - medium	2:1	2 needle seaming
514/IV-S-41	4	512	3 row long - medium	3:1	2 needle seaming
515/IV-26	4	515	2 row wide - medium	2:1	seaming
515/IV-27	4	515	2 row narrow-fine	2:1	seaming
515/IV-28	4	515	2 row wide - fine	2:1	seaming
515/IV-29	4	515	2 row narrow-medium	2:1	seaming
515/IV-30	4	515	3 row wide - medium	2:1	seaming
515/IV-31	4	515	3 row wide - coarse	2:1	seaming
515/IV-32	4	515	2 row narrow-coarse	2:1	seaming
515/IV-33	4	515	2 row wide - coarse	2:1	seaming
515/IV-34	4	515	3 row narrow-fine	2:1	seaming
515/IV-35	4	515	3 row narrow-medium	2:1	seaming
515/IV-36	4	515	3 row narrow-coarse	2:1	seaming
515/IV-37	4	515	3 row wide - fine	2:1	seaming
515/IV-38	4	515	3 row wide - medium	3:1	shirring- intermittent
515/IV-39	4	515	3 row wide - coarse	3:1	shirring- intermittent
515/IV-51	4	515	3 row wide - coarse	2:1	seaming - tractor foot
515/IV-52	4	515	2 row wide - coarse	2:1	seaming - tractor foot
516/IV-26	5	516	2 row wide - medium	2:1	seaming
516/IV-27	5	516	2 row narrow-fine	2:1	seaming
516/IV-28	5	516	2 row wide - fine	2:1	seaming
516/IV-29	5	516	2 row narrow-medium	2:1	seaming
516/IV-30	5	516	3 row wide - medium	2:1	seaming
516/IV-31	5	516	3 row wide - coarse	2:1	seaming
516/IV-32	5	516	2 row narrow-coarse	2:1	seaming
516/IV-33	5	516	2 row wide - coarse	2:1	seaming
516/IV-34	5	516	3 row narrow-fine	2:1	seaming
516/IV-35	5	516	3 row narrow-medium	2:1	seaming
516/IV-36	5	516	3 row narrow-coarse	2:1	seaming
516/IV-37	5	516	3 row wide - fine	2:1	seaming
516/IV-38	5	516	3 row wide - medium	3:1	shirring-intermittent
516/IV-39	5	516	3 row wide - coarse	3:1	shirring-intermittent
516/IV-51	5	516	3 row wide - coarse	2:1	seaming - tractor foot
516/IV-52	5	516	2 row wide - coarse	2:1	seaming - tractor foot

W & G 500 CLASS MODEL SPECIFICATION AND SUMMARY SHEET

CLASS 500 MACHINES

FEDERAL STITCH	MACHINE CLASS I II III IV V VI	TYPE NO. OPERATION	MATERIAL L M H W K	FEED & PLATE PATTERN								FEED MECHANISM			NO. OF THREADS
				Rows	Width	Length	Pitch	PLAIN DIFFERENTIAL			Fixed	Intermittent			
				1 2 3	W N	L S F M C	1/2:1	1:1	2:1 3:1						
504	0	-1 seaming	0	0	0	0	0	0	0	0	0	0	0	0	3
504	0	-2 seaming & stretch	0	0	0	0	0	0	0	0	0	0	0	0	3
504	0 0	-3 seaming	0	0	0	0	0	0	0	0	0	0	0	0	3
503	0 0	-4 serging	0 0	0	0	0	0	0	0	0	0	0	0	0	2
504	0 0	-5 seaming	0 0	0	0	0	0	0	0	0	0	0	0	0	3
504	0 0	-6 seaming & stretch	0	0	0	0	0	0	0	0	0	0	0	0	3
504	0 0	-7 seaming	0	0	0	0	0	0	0	0	0	0	0	0	3
503	0 0	-8 serging	0	0	0	0	0	0	0	0	0	0	0	0	2
504	0	-9 downturn hemming	0	0	0	0	0	0	0	0	0	0	0	0	3
504	0	-10 upturn hemming	0	0	0	0	0	0	0	0	0	0	0	0	3
514(512)	0 0	-11 2needle seaming	0	0	0	0	0	0	0	0	0	0	0	0	4
514(512)	0 0	-12 2needle seaming	0	0	0	0	0	0	0	0	0	0	0	0	4
		-13 OBSOLETE													
504	0	-14 Shell Stitch	0	0											3
		-15 OBSOLETE													
504	0	-16													
		-17 3:1 shir	0	0	0	0	0	0	0	0	0	0	0	0	3
		-18													
504	0	-19 seaming	0	0	0	0	0	0	0	0	0	0	0	0	3
514	0	-20 2needle seaming	0	0	0	0	0	0	0	0	0	0	0	0	4
504	0	-21 3:1 shir	0	0	0	0	0	0	0	0	0	0	0	0	3
514(512)	0	-22 2needle 3:1 shir	0	0	0	0	0	0	0	0	0	0	0	0	4
514(512)	0 0	-23 2needle 3:1 shir	0	0	0	0	0	0	0	0	0	0	0	0	4
		-24													
504(505)	0	-25 herring	0	0	0	0	0	0	0	0	0	0	0	0	2-3
515,516	0	-26 seaming	0	0	0	0	0	0	0	0	0	0	0	0	4-5
515,516	0	-27 seaming	0	0	0	0	0	0	0	0	0	0	0	0	4-5
515,516	0	-28 seaming	0	0	0	0	0	0	0	0	0	0	0	0	4-5
515,516	0	-29 seaming	0	0	0	0	0	0	0	0	0	0	0	0	4-5
515,516	0	-30 seaming	0	0	0	0	0	0	0	0	0	0	0	0	4-5
515,516	0	-31 seaming	0	0	0	0	0	0	0	0	0	0	0	0	4-5
515,516	0	-32 seaming	0	0	0	0	0	0	0	0	0	0	0	0	4-5
515,516	0	-33 seaming	0	0	0	0	0	0	0	0	0	0	0	0	4-5
515,516	0	-34 seaming	0	0	0	0	0	0	0	0	0	0	0	0	4-5
515,516	0	-35 seaming	0	0	0	0	0	0	0	0	0	0	0	0	4-5
515,516	0	-36 seaming	0	0	0	0	0	0	0	0	0	0	0	0	4-5
515,516	0	-37 seaming	0	0	0	0	0	0	0	0	0	0	0	0	4-5
515,516	0	-38 3:1 shir	0	0	0	0	0	0	0	0	0	0	0	0	4-5
515,516	0	-39 3:1 shir	0	0	0	0	0	0	0	0	0	0	0	0	4-5
		-40													
514(512)	0 0	-41 2 needle seaming	0	0	0	0	0	0	0	0	0	0	0	0	4
514(512)	0 0	-42 2 needle seaming	0	0	0	0	0	0	0	0	0	0	0	0	4
504	0 0	-43 seaming	0	0	0	0	0	0	0	0	0	0	0	0	3
503	0 0	-44 serging	0	0	0	0	0	0	0	0	0	0	0	0	2
504	0 0	-45 seaming & stretch	0	0	0	0	0	0	0	0	0	0	0	0	3
		-46													
504	0 0	-47 seaming	0	0	0	0	0	0	0	0	0	0	0	0	3
503	0 0	-48 serging	0	0	0	0	0	0	0	0	0	0	0	0	2
		-49													
515,516	0	-51 seaming-tractorfoot	0	0	0	0	0	0	0	0	0	0	0	0	4-5
515,516	0	-52 seaming-tractorfoot	0	0	0	0	0	0	0	0	0	0	0	0	4-5
		S-10 seaming													
504	0	S-11 2needle seaming	0	0	0	0	0	0	0	0	0	0	0	0	3
514	0	S-12 2needle seaming	0	0	0	0	0	0	0	0	0	0	0	0	4
514	0	S-13 2needle seaming	0	0	0	0	0	0	0	0	0	0	0	0	4
514	0	S-14 2needle seaming	0	0	0	0	0	0	0	0	0	0	0	0	4
514	0	S-15 2needle seaming	0	0	0	0	0	0	0	0	0	0	0	0	4
504	0	S-16 seaming	0	0	0	0	0	0	0	0	0	0	0	0	3
504	0	S-17 seaming	0	0	0	0	0	0	0	0	0	0	0	0	3
514	0	S-18 2needle shir	0	0	0	0	0	0	0	0	0	0	0	0	4
514	0	S-19 2needle seaming	0	0	0	0	0	0	0	0	0	0	0	0	4
514	0	S-20 2needle seaming	0	0	0	0	0	0	0	0	0	0	0	0	4
514(512)	0	S-41 2needle seaming	0	0	0	0	0	0	0	0	0	0	0	0	4
504	0	S-45 seaming	0	0	0	0	0	0	0	0	0	0	0	0	3
504	0	S-47 seaming	0	0	0	0	0	0	0	0	0	0	0	0	3

NEEDLE
Curved ○
Straight ⊕

CAPACITY
Low Lift - 1/8 x 5/32" ○
High Lift- 1/4 x 1/4" ⊕

MATERIAL
L- Light
M- Medium
H- Heavy

W- Woven
K- Knit

FEED AND PLATE PATTERN
W- Wide L- Long
N- Narrow S- Short

F-Fine (25 teeth per inch)
M-Medium (16 teeth per inch)
C-Coarse (10 teeth per inch)